





**DR NKOSAZANA DLAMINI ZUMA LOCAL MUNICIPALITY**

**CONSTRUCTION OF CREIGHTON TOWN UPGRADE PHASE 2  
CONTRACT No. PWBS-: B035/22/23**

**CIDB CONTRACTOR GRADING  
3CE OR HIGHER**

<p>COMPILED BY:</p>  <p>FMA ENGINEERS (PTY) LTD 18 YORK ROAD GILLITTS 3610</p> <p>Tel N°: +27 31 764 2763 Fax N°: +27 86 542 4084 Email: admin@fmaengineers.co.za</p>	<p>ON BEHALF OF:</p>  <p>DR NKOSAZANA DLAMINI ZUMA MUNICIPALITY P O BOX 62 CREIGHTON 3263</p> <p>Tel N°: +27 39 833 1038 Fax N°: +27 39 833 1179 Email: mngadis@ndz.gov.za</p>
--	---

**COMPULSORY SITE INSPECTION: 28<sup>th</sup> OCTOBER 2022**

NAME OF TENDERER	
ADDRESS OF TENDERER	
TELEPHONE	
FAX	
TENDER SUM	

**TENDER CLOSING DATE: 08<sup>th</sup> NOVEMBER 2022 AT 12H00**



## CONSTRUCTION OF CREIGHTON TOWN UPGRADE (PHASE 2)

CONTRACT No. PWBS-: B035/22/23

### TABLE OF CONTENTS

PART	DESCRIPTION	PAGE COLOUR	PAGE No.
<b>PART T: TENDER</b>			
T1	Tendering Procedures	White	TP. 3
T1.1	Tender Notice and Invitation to Tender	White	TP. 3
T1.2	Tender Data	Pink	TP.7
T2	Returnable Documents and Schedules	Yellow	RD. 2
T2.1	List of Returnable Documents	Yellow	RD. 2
T2.2	List of Returnable Schedules and Forms	Yellow	RD. 29
<b>PART C: CONTRACT</b>			
C1	Agreements and Contract Data	Yellow	C. 3
C1.1	Form Offer and Acceptance	Yellow	C. 3
C1.2	Contract Data	Yellow	C. 9
C1.3	Performance Guarantee	Yellow	C. 13
C1.4	Disclosure Statement	Yellow	C. 16
C1.5	Adjudication Board Member Agreement	Yellow	C. 17
C1.6	Retention Money Guarantee (PRO FORMA)	White	C. 19
C1.7	Agreement in terms of section 37(2) of the Occupational Health and Safety Act No.85 of 1993	White	C. 21
C2	Pricing data	Yellow	PD. 1
C2.1	Pricing Instructions	Yellow	PD. 2
C2.2	Schedule of Quantities	Yellow	PD. 5
C3	Scope of Work	Blue	SW. 2
C4	Site Information	Green	SI. 2
	Drawings	White	SI. 3

## **THE TENDER**

T1: TENDERING PROCEDURES

T2: RETURNABLE DOCUMENTS

## TABLE OF CONTENTS

	<b>PAGE NO.</b>
T1: TENDERING PROCEDURES .....	TP. 3
T1.1: TENDER NOTICE AND INVITATION TO TENDER .....	TP. 3
T1.2: TENDER DATA .....	TP. 7

## T1: TENDERING PROCEDURES

### T1.1: TENDER NOTICE AND INVITATION TO TENDER: No PWBS-: B035/22/23



#### BID INVITATION

Bids are hereby invited from suitably qualified and experienced Service Providers for the Projects as indicated below within Dr Nkosazana Dlamini – Zuma Municipality (KZN 436).

This bid will be evaluated in terms of the Pre-qualification, functionality and 80/20 Preferential Procurement Point system and the points will be allocated as follows. **80 – Price, 20 - BBBEE.**

#### PRE –QUALIFICATION

The Municipality will only accept the bids from bidders who have sub – contracted a minimum of 30% to an EME or QSE which is atleast 51% owned by black people who are; women or youth or with disability. List of SMME local database is available on the municipal website([www.ndz.gov.za](http://www.ndz.gov.za)).

#### COMPULSORY SITE INSPECTION

The meeting point for the Briefing will be at Dr Nkosazana Dlamini – Zuma Municipality offices in Main Street, Creighton. A representative from Dr Nkosazana Dlamini – Zuma Municipality will meet prospective Bidders to provide details of the Contract. **NB: Please be advised that only attendance register will be signed during the 1<sup>st</sup> session of briefing and Documents will be signed on site.**

PROJECT NAME	CONTRACT NO.	CIDB Grade	BRIEFING DATE AND TIME
UNDERBERG TOWN UPGRADE PHASE 2	PWBS-B044/22/23	Grade 3 CE or Higher	28 <sup>th</sup> October 2022 @10h00
CONSTRUCTION OF CREIGHTON TOWN UPGRADE (PHASE 2)	PWBS-B035/22/23	Grade 3 CE or Higher	28 <sup>th</sup> October 2022 @10h00

#### DOCUMENTS

Bid documents will be available at the Creighton Office from the **19<sup>th</sup> October 2022** during office hours. The cost of the bid document is **R476.00** which is non-refundable. An Electronic copy is available on our website ([www.ndz.gov.za](http://www.ndz.gov.za)) for **FREE**.

#### THE FOLLOWING DOCUMENTS ARE TO BE SUBMITTED WITH THE BID

- Valid tax clearance certificate or Tax Compliance Status PIN
- Submit proof that the bidder and its directors do not owe municipal rates and services.
- Copy of a certificate of Company Registration with the Registrar of Companies and CC's (CK).
- Certified copy of B-BBEE certificate or sworn affidavit
- Certified copies of ID's.
- Form of offer fully completed
- MDB 1, 4 ,6.2, 8 ,9 and Annexures C, D & E fully completed.
- Proof of registration with CSD
- **CIDB Grade Certificate**

**CLOSING DATE**

Bid documents must be submitted in a sealed envelope clearly marked with the Bid number and closing date and dropped off in the tender box at the **Dr Nkosazana Dlamini Zuma Municipality Offices, Main street, Creighton** by no later than **the 08<sup>th</sup> November 2022 before 12:00pm**. Late or faxed bids will not be accepted. Failure to comply with the above conditions will invalidate your offer.

The Dr Nkosazana Dlamini Zuma Municipality reserves the right not to make an appointment.

**NB: Bids will remain valid for a period of 90 days from date of the closing of the Bid.**  
**N.B: The stipulated minimum threshold for local production and content for these Bids is as follows:**

Project Name	Industry/sector/sub-sector	Minimum threshold for local content
UNDERBERG TOWN UPGRADE PHASE 2	Steel value added products (Reinforcement, road signs)	100%
	Cement products	100%
	Clothing and Textile	100%
CONSTRUCTION OF CREIGHTON TOWN UPGRADE (PHASE 2)	Steel value added products (Gabions, Reinforcement and Road signs)	100%
	Cement products	100%
	Clothing and Textile	100%
	Street Light Steel Poles	100%
	Electrical Cables	90%

Only locally produced goods, services or works or locally manufactured goods, with a stipulated minimum threshold for local production and content will be considered.

Inquiries may be directed to the following persons during office hours (08:00 – 16:30)

**BID ENQUIRIES**

Procedure related enquires: Miss N. Holiwe  
Technical Enquiries: Mr S.V Mngadi or Mr Z. Dlamini  
Dr Nkosazana Dlamini Zuma Municipality Tel No: (039) 833 1038  
P O Box 62 Fax No.: (039) 833 1179  
Creighton  
3263

  
Mr N.C Vezl  
MUNICIPAL MANAGER

ENTERED 14 OCT 2022

**MDB**

**INVITATION TO BID**

<b>YOU ARE HEREBY INVITED TO BID FOR REQUIREMENTS OF THE (NAME OF MUNICIPALITY/MUNICIPAL ENTITY)</b>					
BID NUMBER:	PWBS-B035/22/23	CLOSING DATE:	08 <sup>th</sup> NOVEMBER 2022	CLOSING TIME:	12h00
DESCRIPTION	CONSTRUCTION OF CREIGHTON TOWN UPGRADE PHASE 2				
<b>THE SUCCESSFUL BIDDER WILL BE REQUIRED TO FILL IN AND SIGN A WRITTEN CONTRACT FORM (MBD7).</b>					
BID RESPONSE DOCUMENTS MAY BE DEPOSITED IN THE BID BOX SITUATED AT (Dr NDZ Main Offices at Main street, Creighton 3263)					
<b>MAIN STREET</b>					
<b>CREIGHTON, 3263</b>					
<b>SUPPLIER INFORMATION</b>					
NAME OF BIDDER					
POSTAL ADDRESS					
STREET ADDRESS					
TELEPHONE NUMBER	CODE		NUMBER		
CELLPHONE NUMBER					
FACSIMILE NUMBER	CODE		NUMBER		
E-MAIL ADDRESS					
VAT REGISTRATION NUMBER					
TAX COMPLIANCE STATUS	TCS PIN:		OR	CSD No:	
B-BBEE STATUS LEVEL VERIFICATION CERTIFICATE [TICK APPLICABLE BOX]	<input type="checkbox"/> Yes <input type="checkbox"/> No		B-BBEE STATUS LEVEL SWORN AFFIDAVIT	<input type="checkbox"/> Yes <input type="checkbox"/> No	
<b>[A B-BBEE STATUS LEVEL VERIFICATION CERTIFICATE/ SWORN AFFIDAVIT (FOR EMES &amp; QSEs) MUST BE SUBMITTED IN ORDER TO QUALIFY FOR PREFERENCE POINTS FOR B-BBEE]</b>					
1. ARE YOU THE ACCREDITED REPRESENTATIVE IN SOUTH AFRICA FOR THE GOODS /SERVICES /WORKS OFFERED?	<input type="checkbox"/> Yes <input type="checkbox"/> No [IF YES ENCLOSE PROOF]		2. ARE YOU A FOREIGN BASED SUPPLIER FOR THE GOODS /SERVICES /WORKS OFFERED?	<input type="checkbox"/> Yes <input type="checkbox"/> No [IF YES, ANSWER PART B:3]	
3. TOTAL NUMBER OF ITEMS OFFERED			4. TOTAL BID PRICE	R	
5. SIGNATURE OF BIDDER	.....		6. DATE		
7. CAPACITY UNDER WHICH THIS BID IS SIGNED					
<b>BIDDING PROCEDURE ENQUIRIES MAY BE DIRECTED TO:</b>			<b>TECHNICAL INFORMATION MAY BE DIRECTED TO:</b>		
DEPARTMENT	BTO		CONTACT PERSON	PWBS	
CONTACT PERSON	Miss N Holiwe		TELEPHONE NUMBER	039 833 1039	
TELEPHONE NUMBER	039 833 1039		FACSIMILE NUMBER		
FACSIMILE NUMBER	086 583 235		E-MAIL ADDRESS	dlaminiz@ndz.gov.za	
E-MAIL ADDRESS	holiwen@ndz.gov.za				

**PART B  
TERMS AND CONDITIONS FOR BIDDING**

<b>1. BID SUBMISSION:</b>	
1.1.	BIDS MUST BE DELIVERED BY THE STIPULATED TIME TO THE CORRECT ADDRESS. LATE BIDS WILL NOT BE ACCEPTED FOR CONSIDERATION.
1.2.	<b>ALL BIDS MUST BE SUBMITTED ON THE OFFICIAL FORMS PROVIDED-(NOT TO BE RE-TYPED) OR ONLINE</b>
1.3.	THIS BID IS SUBJECT TO THE PREFERENTIAL PROCUREMENT POLICY FRAMEWORK ACT AND THE PREFERENTIAL PROCUREMENT REGULATIONS, 2017, THE GENERAL CONDITIONS OF CONTRACT (GCC) AND, IF APPLICABLE, ANY OTHER SPECIAL CONDITIONS OF CONTRACT.
<b>2. TAX COMPLIANCE REQUIREMENTS</b>	
2.1	BIDDERS MUST ENSURE COMPLIANCE WITH THEIR TAX OBLIGATIONS.
2.2	BIDDERS ARE REQUIRED TO SUBMIT THEIR UNIQUE PERSONAL IDENTIFICATION NUMBER (PIN) ISSUED BY SARS TO ENABLE THE ORGAN OF STATE TO VIEW THE TAXPAYER'S PROFILE AND TAX STATUS.
2.3	APPLICATION FOR THE TAX COMPLIANCE STATUS (TCS) CERTIFICATE OR PIN MAY ALSO BE MADE VIA E-FILING. IN ORDER TO USE THIS PROVISION, TAXPAYERS WILL NEED TO REGISTER WITH SARS AS E-FILERS THROUGH THE WEBSITE WWW.SARS.GOV.ZA.
2.4	FOREIGN SUPPLIERS MUST COMPLETE THE PRE-AWARD QUESTIONNAIRE IN PART B.3.
2.5	BIDDERS MAY ALSO SUBMIT A PRINTED TCS CERTIFICATE TOGETHER WITH THE BID.
2.6	IN BIDS WHERE CONSORTIA / JOINT VENTURES / SUB-CONTRACTORS ARE INVOLVED, EACH PARTY MUST SUBMIT A SEPARATE TCS CERTIFICATE / PIN / CSD NUMBER.
2.7	WHERE NO TCS IS AVAILABLE BUT THE BIDDER IS REGISTERED ON THE CENTRAL SUPPLIER DATABASE (CSD), A CSD NUMBER MUST BE PROVIDED.
<b>3. QUESTIONNAIRE TO BIDDING FOREIGN SUPPLIERS</b>	
3.1.	IS THE ENTITY A RESIDENT OF THE REPUBLIC OF SOUTH AFRICA (RSA)? <input type="checkbox"/> YES <input type="checkbox"/> NO
3.2.	DOES THE ENTITY HAVE A BRANCH IN THE RSA? <input type="checkbox"/> YES <input type="checkbox"/> NO
3.3.	DOES THE ENTITY HAVE A PERMANENT ESTABLISHMENT IN THE RSA? <input type="checkbox"/> YES <input type="checkbox"/> NO
3.4.	DOES THE ENTITY HAVE ANY SOURCE OF INCOME IN THE RSA? <input type="checkbox"/> YES <input type="checkbox"/> NO
3.5.	IS THE ENTITY LIABLE IN THE RSA FOR ANY FORM OF TAXATION? <input type="checkbox"/> YES <input type="checkbox"/> NO
<b>IF THE ANSWER IS "NO" TO ALL OF THE ABOVE, THEN IT IS NOT A REQUIREMENT TO REGISTER FOR A TAX COMPLIANCE STATUS SYSTEM PIN CODE FROM THE SOUTH AFRICAN REVENUE SERVICE (SARS) AND IF NOT REGISTER AS PER 2.3 ABOVE.</b>	

**NB: FAILURE TO PROVIDE ANY OF THE ABOVE PARTICULARS MAY RENDER THE BID INVALID.  
NO BIDS WILL BE CONSIDERED FROM PERSONS IN THE SERVICE OF THE STATE.**

SIGNATURE OF BIDDER: .....

CAPACITY UNDER WHICH THIS BID IS SIGNED: .....

DATE: .....



## T1.2: TENDER DATA

### T1.2.1 Standard Conditions of Tender

The conditions of tender are the Standard Conditions of Tender as contained in of Board Notice 136 of 2016 in Government Gazette No 38960 of 10 July 2016, Construction Industry Development Board (CIDB) Standard for Uniformity in Construction Procurement. Annexure F and Table G1 of that notice are deliberately not reproduced in this document; tenderers may review the standard on the CIDB website (see [www.cidb.org.za](http://www.cidb.org.za)).

### T1.2.2 Variations to the Standard Conditions of Tender

The Standard Conditions of Tender make several references to the Tender Data for details that apply specifically to this tender. The Tender Data shall take precedence in the interpretation of any ambiguity or inconsistency between it and the standard conditions of tender. Each item of data given below is cross referenced to the clause in the Standard Conditions of Tender to which it mainly applies.

The following variations, amendments and additions to the Standard Conditions of Tender shall apply to this tender.

Please note that the word “Client” is used in this document and referred to as “Employer” in the Standard Conditions of Tender document.

Clause Number	Description
<b>F.1</b>	<b>General</b>
F.1.1	Actions
	The Employer is Dr Nkosazana Dlamini Zuma Local Municipality, represented by Mr. S. Mngadi
<b>F.1.2</b>	<b>Tender Documents</b>
	<p>The tender documents issued by the employer comprise the following:</p> <p><b>THE TENDER</b></p> <p><b>T1: Tendering Procedures</b></p> <p>T1.1 Tender Notice and Invitation to Tender</p> <p>T1.2 Tender Data</p> <p><b>T2: Returnable Documents</b></p> <p>T2.1 List of Returnable Documents</p> <p>T2.2 Returnable Schedules</p> <p><b>THE CONTRACT</b></p> <p><b>C1: Agreements and Contract Data</b></p> <p>C1.1 Form of Offer and Acceptance</p> <p>C1.2 Contract Data</p> <p>C1.3 Performance Guarantee</p> <p>C1.4 Retention Money Guarantee</p> <p>C1.5 Agreement in terms of Section 37(2) of the Occupational Health and Safety Act No. 85 of 1993</p> <p>C1.6 Functionality Criteria</p> <p><b>C2: Pricing data</b></p> <p>C2.1 Pricing Instructions</p>

	<p>C2.2 Schedule of Quantities</p> <p><b>C3: Scope of work</b></p> <p>C3.1 Standard Specifications                  C3.2 Project Specifications                  C3.3 Particular Specifications</p> <p><b>C4: Site information</b></p> <p>C4.1 Locality Plan                  C4.2 Drawings</p> <p>Not issued to Tenderer's, but available from the Master Builders Association, The South Institute of Architects, the Government printers, the Construction Industry Development Board, and the Employer, as applicable:</p> <ol style="list-style-type: none"> <li>1. CIDB, "<i>The Standard for Uniformity in Construction Procurement Annex F, Standard Conditions of Tender</i>", Board Notice 136 of 2016 of Government Gazette 38960 of 10 July 2016.</li> <li>2. GCCC SERIES 2015 "<i>General Conditions of Contract for Construction Works Agreement</i>", Third Edition– 2015.</li> <li>3. The "<i>COLTO Standard Specifications for Road and Bridge Works for State Road Authorities</i>", 1998 edition.</li> <li>4. The "<i>Occupational Health and Safety Act No 85 and Amendment Act No 181 of 1993, and the Construction Regulations 2014 (Government Gazette No 37305 of 7 February 2014, Notice No R. 84)</i>".</li> <li>5. The Preferential Procurement Policy Framework Act No 5 of 2000, and the Preferential Procurement Policy Framework Act Regulations (June 2011).</li> </ol>
<b>F.1.4</b>	<b>Communication and the Employer's Agent</b>
	<p>Attention is drawn to the fact that verbal information, given by the Employer's Agent during site visits/clarification meetings or at any other time prior to the award of the Contract, will not be regarded as binding on the Employer. Only information issued formally by the Employers Agent in writing to tenderers will be regarded as amending the Tender Documents.</p> <p>The Employer's Agent is: FMA ENGINEERS (PTY) LTD</p> <p>Address: 18 York Road                  GILLITTS                  3610</p> <p>Tel N<sup>o</sup>: +27 (31) 764 2763                  Fax N<sup>o</sup>: +27 (86) 542 4084                  Contact Person: Hlosokuhle Fuyana                  Email: admin@fmaengineers.co.za</p>
<b>F.2</b>	<b>Tenderer's Obligations</b>
<b>F.2.1</b>	<b>Eligibility</b>
F.2.1.1	<p>Tenderers must satisfy the following criteria in order to be eligible to submit a tender;</p> <p><b>A. Construction Industry Development Board (CIDB) Registration</b></p> <ol style="list-style-type: none"> <li>1. Be registered with the CIDB and reflect as "Active" at time of tender closing, in a contractor grading designation equal to or higher than a contractor grading designation determined in accordance with the sum tendered, or a value determined in accordance with Regulation 25 (1B) or 25(7A) of the Construction Industry Development Regulations, but not less than <b>3CE OR</b></li> </ol>

**HIGHER** class of construction work.

**B. Joint Ventures are eligible to submit a tender offer provided that:**

1. Every member of the joint venture is registered (as “Active”) with the CIDB (at the time of tender closing).
2. The lead partner has a contractor grading designation in the CE class of construction work and has a grading designation of not lower than one level below the required grading designation.
3. The value of work to be undertaken by each partner must be within their CIDB grading limit.
4. The combined contractor grading designation calculated in accordance with the Construction Industry Development Board Regulations (2016) is equal to or higher than a contractor grading designation determined in accordance with the sum tendered for a CE class of construction work or a value determined in accordance with Regulation 25(1B) or 25(7A) of the Construction Industry Development Regulations:

Designation	Deemed to satisfy joint venture arrangements
3	Three contractors registered in contractor grading designation 2
4	Three contractors registered in contractor grading designation 3
5	Two contractors registered in contractor grading designation 4 One contractor registered in contractor grading designation 4 and two registered in contractor grading designation 3
6	Two contractors registered in contractor grading designation 5 One contractor registered in contractor grading designation 5 and two registered in contractor grading designation 4
7	Two contractors registered in contractor grading designation 6 One contractor registered in contractor grading designation 6 and two registered in contractor grading designation 5
8	Three contractors registered in contractor grading designation 7
9	Three contractors registered in contractor grading designation 8

5. Tenders submitted by joint ventures of two or more firms must be accompanied by the document of formation of the joint venture, authenticated by a notary public or other official deputed to witness sworn statements, in which is defines precisely the conditions under which the joint venture will function, its period of duration, the persons authorised to represent and obligate it, the participation of the several firms forming the joint venture, and any other information necessary to permit a full appraisal of its functioning.
6. The Tenderer, if a Joint Venture, must submit a signed JV Agreement with the tender specific to the tendered Contract and clearly showing the percentage contribution of each partner to the Joint Venture. The value of work to be undertaken by each partner must be within their CIDB grading limit.

**C. National Treasury Central Supplier Database Registration**

Only Tenderers who are to be registered on the National Treasury Central Supplier (CSD) Database and have provided proof of their registration will be eligible to submit a tender offer. Proof of registration must be in the form of the Tenderers CSD registration number. Tenderers who are not registered are not precluded from submitting bids but must be registered prior to Contract Award.

In the case of Joint Venture partnerships this requirement will apply individually to each party to the Joint Venture.

Tenderers who wish to register as service providers on the CSD can register online at <https://secure.csd.gov.za/Account/Register>.

	<p><b>D. Attendance of Compulsory Site Briefing</b></p> <p>Tenderers must attend the compulsory site briefing and have Form A3 “Certificate of attendance of Site Inspection Meeting” signed by the Employers agent or his representative will be eligible to submit a tender offer.</p> <p><b>E. Labour Intensive Construction</b></p> <p>The tenderer must demonstrate that they have in their employment suitable qualified management and supervisory personnel with an NQF 5 from a CETA accredited training provider in labour intensive construction.</p> <p><b>F. Tenderer’s Tax Clearance Matters</b></p> <p>The Tenderer cannot provide proof that he is in good standing with respect to duties, taxes, levies and contributions required in terms of legislation applicable to the work in the contract.</p>																
<p>F.2.1.3</p>	<p>Only those tenderers who can demonstrate that;</p> <ul style="list-style-type: none"> <li>a. they will have in their employ, management and supervisory staff satisfying the requirements of the scope of work for labour intensive competencies; for supervisory and management staff during the validity of the contract, are eligible to submit tenders.</li> </ul> <p><b>Tender Qualification: Labour Intensive Contracts</b></p> <p>To qualify for award of the Contract, tenderers shall meet the following minimum qualifying criteria:</p> <ul style="list-style-type: none"> <li>a. Having participated in and graduated with fully satisfactory results from the relevant national qualification framework training organized under EPWP (or other similar project) and applying trained supervisory staff on a full-time basis for the execution of the works. LIC NQF Level 5.</li> <li>b. Liquid assets/or credit facilities covering the expected expenditures for two full work months</li> <li>c. Proposals for timely acquisition (own, lease, hire, etc.) of the essential minimum equipment</li> <li>d. The contractor will carry out the works using labour-based work methods as described in the Special Conditions of Contract</li> </ul> <p>The tenderer must submit to the Employer, names of all management and supervisory staff that will be employed to supervise the labour-intensive portion of the works together with satisfactory evidence that such staff members satisfy the eligibility requirement. The contractor shall ensure that the minimum supervisor to worker ratio of 1:15 for effective supervision of Labour-intensive works for all LI activities.</p>																
<p>F.2.1.4</p>	<p><b>Schedule of Labour Content</b></p> <p>The minimum unskilled labour Content for this Project, i.e. the minimum job creation targets on the project shall be:</p> <table border="1" data-bbox="305 1486 1239 1675"> <thead> <tr> <th></th> <th><b>Total</b></th> <th><b>Women</b></th> <th><b>Youth</b></th> </tr> </thead> <tbody> <tr> <td>Minimum Work Opportunities</td> <td><b>12</b></td> <td>4</td> <td>8</td> </tr> <tr> <td>Man Hours</td> <td><b>10,080</b></td> <td>7,056</td> <td>3,027</td> </tr> <tr> <td>Man Days</td> <td><b>1,260</b></td> <td>882</td> <td>378</td> </tr> </tbody> </table>		<b>Total</b>	<b>Women</b>	<b>Youth</b>	Minimum Work Opportunities	<b>12</b>	4	8	Man Hours	<b>10,080</b>	7,056	3,027	Man Days	<b>1,260</b>	882	378
	<b>Total</b>	<b>Women</b>	<b>Youth</b>														
Minimum Work Opportunities	<b>12</b>	4	8														
Man Hours	<b>10,080</b>	7,056	3,027														
Man Days	<b>1,260</b>	882	378														
<p><b>F.2.7</b></p>	<p><b>Clarification Meeting</b></p>																

	<p><i>Add the following to the end of Clause F.2.7:</i></p> <p>The arrangement for a compulsory clarification meeting is as stated in the Tender Notice and Invitation to Tender. Tenderers should be represented at the clarification meeting by a person or persons who are suitably qualified and experienced.</p>
F2.8	<p>Add the following to the clause</p> <p>Accept that <b>failure to request clarification</b> on tender documents, in at least 2 working days prior to the closing time stated in the tender data, it shall be deemed that all matters in the tender documents are clearly understood. Accept that the Employer shall not be obligated to respond to any requests for clarification of tender documents submitted in less than 5 working days prior to the closing date.</p>
<b>F.2.10.3</b>	<b>Pricing the Tender Offer</b>
	This tender is NOT subject to Contract Price Adjustment.
<b>F.2.12</b>	<b>Alternative Tender Offers</b>
	No alternative offers will be accepted. This includes offering fixed rates in lieu of Contract Price Adjustment.
<b>F.2.13</b>	<b>Submitting a tender offer</b>
F2.13.2	<p>“Return all returnable documents to the Employer after completing them in their entirety. Notwithstanding the format in which the tender documents are issued to Tenderers, no electronic form of tender offers will be accepted.</p> <p>Where additional supporting documentation is provided or required in terms of the Returnable Schedules listed in T2.1: List of Returnable Schedules, this shall be placed in a file labelled “Supporting Documentation”, and further labelled in accordance with F2.13.5 of T1.2: Tender Data. The file shall be provided with a Table of Contents matching the relevant items for T2.1 and shall be provided with labelled dividers for each of the corresponding sections wherein the supporting documentation shall be inserted. Failure to comply with these requirements may result in the tender being declared non-responsive.</p> <p>Notwithstanding any statement in any of the Returnable Schedules listed in T2.1 to the effect that supporting documentation must be attached to the associated Returnable Schedule, the supporting documentation must be placed in the supporting documentation files as stipulated above. The Schedule of Quantities must be fully and correctly filled in in by hand in black ink.”</p>
<b>F2.13.3</b>	<p>Number of copies required is One (1) original and one (1) complete copy.</p> <p>Telephonic, facsimile or e-mailed tender offers will not be accepted.</p> <p>The binding for the original volumes of the Tender Document may be dismantled, but must be submitted in the original format in which they were issued by the Employer.</p>
<b>F.2.13.4</b>	The tender shall be signed by a person duly authorised to do so.
<b>F.2.13.5</b>	<p>The Employer’s address for delivery of tender offers and identification details, to be shown on each tender offer package, are the following:</p> <p><b>Location of Tender Box:</b> Dr Nkosazana Dlamini Zuma Local Municipality Offices</p> <p><b>Physical Address:</b> Main Street, CREIGHTON, 3263.</p>

	The identification details which must be stated in the tender offer outer package are: <b>Tender Number: PWBS-: B035/22/23</b> <b>Title of Tender: CONSTRUCTION OF CREIGHTON TOWN UPGARDE PHASE 2</b>		
<b>F.2.13.6</b>	A two-envelope Procedure as described in Clause F.3.5 <b>will not be followed.</b>		
<b>F.2.15</b>	<b>Closing Time</b>		
F.2.15.1	The closing time for submission of tender offers is as stated in the Tender Notice and Invitation to Tender.		
<b>F.2.16</b>	<b>Tender offer validity</b>		
F.2.16.1	The tender offer validity period is one hundred and twenty (120) days from the closing date.		
F.2.16.2	The maximum extension on the tender offer validity period is 90 days.		
<b>F.2.17</b>	<b>Clarification of Tender Offer after Submission</b>		
	<p>a. A tender may be rejected as non-responsive if the Tenderer fails to provide any clarification requested by the Employer, or confirmation of registration with CIDB within the time for submission stated in the Employer's written request for such clarification or confirmation.</p> <p>b. A tender may be rejected if the unit rates or lump sums for some of the items in the bills/schedules of quantities are, in the opinion of the Employer, unreasonable or out of proportion, and the Tenderer fails, within the time stated in writing by the Employer to justify any specific rates or lump sums (i.e. to provide a financial breakdown of how such rates or sums were obtained) or to adjust the unit rates or lump sums for such items while retaining the total of the prices unchanged.</p>		
<b>F.2.23</b>	The tenderer is required to submit with his tender:		
		<b>COMPULSORY DOCUMENTS</b>	<b>TICK</b>
	a)	Proof of registration with CSD- starting with <b>(MAAA)</b>	
	b)	Joint Venture Agreement (if necessary)	
	c)	Form of offer fully completed	
	d)	MBD 1,4,6,2,8, 9 and annexure C fully completed	
	e)	CIDB Grading Certificate: <b>3CE or Higher</b>	
	f)	The Municipality will only accept the bids from bidders who have sub – contracted a minimum of 30% to an EME or QSE which is at least 51% owned by black people who are; women or youth or with disability. List of SMME local database is available on the municipal website( <a href="http://www.ndz.gov.za">www.ndz.gov.za</a> ). <b>(NB: Tender must include the following information for proposed Subcontractors</b> CSD report, CIDB certificate or CIRIS number and tax compliance status form	

<b>NB: Failure to submit the above documents your tender will be disqualified</b>															
	<table border="1"> <thead> <tr> <th><b>DOCUMENTS TO BE SUBMITTED</b></th> <th><b>TICK</b></th> </tr> </thead> <tbody> <tr> <td>a) Certified Copies of CK Documents / Sole proprietary</td> <td></td> </tr> <tr> <td>b) Valid Tax clearance certificate (with your pin number print and attach on the document Tax Clearance Certificate)</td> <td></td> </tr> <tr> <td>c) Certified copies of Identification documents of all members/directors of the entity</td> <td></td> </tr> <tr> <td>d) Certified BBBEE verification certificate for Preferential points claim or sworn affidavit</td> <td></td> </tr> <tr> <td>e) Submit proof that the bidder (Company) and its (directors) do not owe municipal services.                      -Attach updated municipal rates, water or electricity statement not in arrears for more than 90 days                      Or                      -Attach a valid lease agreement if the director is leasing offices and residential Property with a confirmation letter from the landlord confirming that the municipal rates and services are in order                      Or                      Attach exemption letter from the relevant municipality.                      Or                      Attach affidavit if the Municipal Account is under your parents or siblings and they are responsible for paying municipal rates (if the address is the same as yours) and attach the copy of the Municipal rates and services for the above mentioned.                      Or                      Attach copy of a marriage certificate or affidavit and municipal account statement for rates and services, if Municipal account is under your spouse.</td> <td></td> </tr> <tr> <td>f) annexures D &amp; E fully completed( to be kept by service provider for 5years)</td> <td></td> </tr> </tbody> </table>	<b>DOCUMENTS TO BE SUBMITTED</b>	<b>TICK</b>	a) Certified Copies of CK Documents / Sole proprietary		b) Valid Tax clearance certificate (with your pin number print and attach on the document Tax Clearance Certificate)		c) Certified copies of Identification documents of all members/directors of the entity		d) Certified BBBEE verification certificate for Preferential points claim or sworn affidavit		e) Submit proof that the bidder (Company) and its (directors) do not owe municipal services. -Attach updated municipal rates, water or electricity statement not in arrears for more than 90 days Or -Attach a valid lease agreement if the director is leasing offices and residential Property with a confirmation letter from the landlord confirming that the municipal rates and services are in order Or Attach exemption letter from the relevant municipality. Or Attach affidavit if the Municipal Account is under your parents or siblings and they are responsible for paying municipal rates (if the address is the same as yours) and attach the copy of the Municipal rates and services for the above mentioned. Or Attach copy of a marriage certificate or affidavit and municipal account statement for rates and services, if Municipal account is under your spouse.		f) annexures D & E fully completed( to be kept by service provider for 5years)	
<b>DOCUMENTS TO BE SUBMITTED</b>	<b>TICK</b>														
a) Certified Copies of CK Documents / Sole proprietary															
b) Valid Tax clearance certificate (with your pin number print and attach on the document Tax Clearance Certificate)															
c) Certified copies of Identification documents of all members/directors of the entity															
d) Certified BBBEE verification certificate for Preferential points claim or sworn affidavit															
e) Submit proof that the bidder (Company) and its (directors) do not owe municipal services. -Attach updated municipal rates, water or electricity statement not in arrears for more than 90 days Or -Attach a valid lease agreement if the director is leasing offices and residential Property with a confirmation letter from the landlord confirming that the municipal rates and services are in order Or Attach exemption letter from the relevant municipality. Or Attach affidavit if the Municipal Account is under your parents or siblings and they are responsible for paying municipal rates (if the address is the same as yours) and attach the copy of the Municipal rates and services for the above mentioned. Or Attach copy of a marriage certificate or affidavit and municipal account statement for rates and services, if Municipal account is under your spouse.															
f) annexures D & E fully completed( to be kept by service provider for 5years)															
<b>F.3</b>	<b>The employer's undertakings</b>														
<b>F.3.1</b>	<b>Respond to Requests from the Tenderer</b>														
F.3.1.1	The Employer will respond to a request for clarification received up to five working days before the tender closing time stated in the Tender Data and notify all tenderers who drew tender documents.														
<b>F.3.4</b>	<b>Opening of Tender Submissions</b>														
F.3.4.1	The time and location for Public Opening of the tender offers received will be: <b>Time: 12h00 on 08<sup>th</sup> November 2022</b> <b>Location: Dr Nkosazana Dlamini Zuma Local Municipality</b>														
F.3.4.2	"number of points claimed for its BBBEE status level"														
<b>F.3.7</b>	<b>Grounds for rejection and disqualification</b>														
	Tenderers will be disqualified if any if,														

	<p>a. Any of the directors/shareholders of the Tenderer is listed on the National Treasury Register of Tender Defaulters in terms of the Prevention and Combating of Corrupt Activities Act of 2004 as a person prohibited from doing business in the public sector.</p> <p>b. If the Tenderer has completed the Compulsory Enterprise Questionnaire and is considered by the Employer to have a conflict of interest, which may impact on the Tenderers ability to perform the proposed contract in the best interest of the Employer or potentially compromise the tender process.</p> <p>c. If the Tenderer has persons in the service of the state who are not permitted to submit tenders or to participate in the contract”.</p>
<b>F.3.8</b>	<b>Test for Responsiveness</b>
F.3.8.2	<p>“Tenders will also be considered non-responsive if:</p> <p>a. The Tenderer offer does not meet any one of the eligibility criteria specified in Clause F.2.1 as amended.</p> <p>b. The Tenderer has not fully and correctly completed the Offer portion of C1.1 Form of Offer and Acceptance i.e. the price has not been completed in words and numbers, the Tenderers details are not completed fully and correctly and the Tenderer has failed to sign the Form of Offer on pg. C1.1.</p> <p>c. If requested by the Employer during the tender evaluation process, the Tenderer has failed to clarify or submit any supporting documentation within the time for submission stated in the Employer’s written request.</p> <p>d. The Tenderer’s price is based on fixed rates in lieu of Contract Price Adjustment.</p> <p>e. There are any other material deficiencies whereby the price submitted is not for the identical requirements and scope of work as other correctly completed tenders (such as failing to incorporate the requirements of Addenda where these materially affected the pricing e.g. where the Notice to Tenderers required additions or replacements of part or all of the Bill of Quantities and the submitted Bill of Quantities does not reflect these changes).”</p>
<b>F.3.11</b>	<b>Evaluation of tender offers</b>
F.3.11.1	General
	The Procedure for the evaluation of responsive tenders is Method 1: Price and Preference. Quality (functionality) will be used as a prequalifying criterion, with tenderers required to meet a minimum quality score of <b>60%</b> to qualify for further evaluation.
F.3.11.7	<b>Scoring Price</b>
	For details of scoring price refer to Returnable Schedule A5: Preference Points Claim Form in terms of the Preferential Procurement Regulations 2017.
F.3.11.8	<b>Scoring Preferences</b>
	<p>For details of scoring preference see Returnable Schedule A5: Preference Points Claim Form in terms of the Preferential Procurement Regulations 2017.</p> <p><b>OBJECTIVE CRITERIA</b></p> <p><b>The locality of supplier/ contractor will be verified using submitted rates clearance certificate and further verification will be done through DR NKOSAZANA DLAMINI ZUMA Municipality Local Economic Development office (LED).</b></p> <p><b>Formula for Calculation of Locality Premium</b></p> <p><b><math>P = \frac{(A - B)}{A} \times 100</math></b></p>



	<p><b>Where;</b></p> <p><b>P = Premium</b> <b>A = Lowest acceptable bidder (not local)</b> <b>B = Local acceptable bidder</b> <b>The municipality will pay a premium within the specified threshold in terms of the municipal SCM policy</b></p>
F.3.11.9	<p><b>Scoring Functionality</b></p>
	<p>The functionality will be applied as a prequalifying criterion to determine the tenderers that qualify for further evaluation. The quality shall be scored as per the table below.</p> <p>Points will be allocated only where the required supporting documentation has been submitted by the tenderer.</p>
	<p style="text-align: center;"><b>DETAILED BREAKDOWN OF FUNCTIONALITY POINTS</b></p>

The procedure for the evaluation of responsive tenders is Method 4 (Functionality, Price and Preferences) using the 80/20 Preferential Point System:

Stage 1: Scoring Quality (Functionality)

Only tenderers who will achieve a score of more than 60% of the total available points will qualify for stage two of the evaluation.

The criteria to be used to evaluate the proposals for the functionality stage will be as follows:

Points

1. Relevant Experience of Enterprise = 35
  2. Experience of Key Personnel = 40
  3. Availability of relevant plant and equipment = 25
- Total Points =100**

Key Aspect of Criterion	Basis for Points Allocation	Max Points	Verification Method
<b>Relevant Experience of the Contractor in Road Construction</b>	<b>3 x Completed</b> Asphalt Road Paving/ Concrete Paving Projects in the last 5 years. Bidders to submit letter of appointment and letter of reference.	35	<ul style="list-style-type: none"> <li>• Appointment Letter and.</li> <li>• Letter of Reference</li> </ul>
	<b>2 x Completed</b> Asphalt Road Paving/ Concrete Paving Projects in the last 5 years. Bidders to submit letter of appointment and letter of reference.	20	<ul style="list-style-type: none"> <li>• Appointment Letter and.</li> <li>• Letter of Reference</li> </ul>
	<b>1 x Completed</b> Asphalt Road Paving/ Concrete Paving Projects in the last 5 years. Bidders to submit letter of appointment and letter of reference.	10	<ul style="list-style-type: none"> <li>• Appointment Letter and.</li> <li>• Letter of Reference</li> </ul>
<b>Qualifications and CV's of Contract Manager</b>	National Diploma in Civil Engineering or Project Management with <b>3 years' experience</b> in Asphalt Road Paving/ Concrete Paving Projects	10	Certified copy of qualification to be attached with detailed CV
	National Diploma in Civil Engineering or Project Management with <b>2 years' experience</b> in Asphalt Road Paving/ Concrete Paving Projects	7	Certified copy of qualification to be attached with detailed CV
	National Diploma in Civil Engineering or Project Management with <b>1 years' experience</b> in Asphalt Road Paving/ Concrete Paving Projects	5	Certified copy of qualification to be attached with detailed CV
<b>Qualifications and CV's of Site Agent</b>	National Diploma or N3 in Civil Engineering with <b>3 years' experience</b> in Asphalt Road Paving/ Concrete Paving Projects	15	Certified copy of qualification to be attached with detailed CV

		National Diploma or N3 in Civil Engineering with <b>2 years' experience</b> in Asphalt Road Paving/ Concrete Paving Projects	10	Certified copy of qualification to be attached with detailed CV	
		National Diploma or N3 in Civil Engineering with <b>1 years' experience</b> in Asphalt Road Paving/ Concrete Paving Projects	5	Certified copy of qualification to be attached with detailed CV	
	<b>Qualifications and CV's of Site Foreman</b>	10 or more years of experience in Asphalt Road Paving/ Concrete Paving Projects	15	Detailed CV to be attached with clear experience and reference	
		6 -9 years of experience in Asphalt Road Paving/ Concrete Paving Projects	10	Detailed CV to be attached with clear experience and reference	
		1 -5 years of experience in Asphalt Road Paving/ Concrete Paving Projects	5	Detailed CV to be attached with clear experience and reference	
	<b>Availability of relevant plant and equipment (Resources)</b>	If the <b>Bidder owns all</b> the required construction plant and equipment for Asphalt Road Paving/ Concrete Paving Projects (Tipper Truck, TLB, Grader or Excavator, Concrete mixer, Water cart, Roller. (Supply Proof of ownership e.g. logbook)	25	Proof of ownership of all the required plant and equipment, e.g logbooks and proof of purchase	
		If the <b>Bidder owns some</b> of the required construction plant and equipment and will <b>hire the other</b> required plant and equipment for Asphalt Road Paving/ Concrete Paving Projects (Tipper Truck, TLB, Grader or Excavator, Concrete Mixer, Water cart, Roller. (Supply Proof of ownership e.g. logbook and pro-forma agreement with plant hire company)	20	Proof of ownership of all the required plant and equipment, e.g. logbooks and proof of purchase + Pro-forma Agreement with Plant Hire Company	
		If the <b>will hire all</b> the required construction plant and equipment for Asphalt Road Paving/ Concrete Paving Projects (Tipper Truck, TLB, Grader or Excavator, Concrete Mixer, Water cart, Roller. (Pro-forma Agreement with Plant Hire)	15	Pro-forma Agreement with Plant Hire	
	<b>Only Bidders who achieve 60% the total available will qualify for the next stage of evaluation.</b>				
	<b>Stage 2: Points and Preferential Points</b>				

Points for price will be evaluated as per the following formula:

$$Ps = 80x \left(1 - \frac{Pt - Pmin}{Pmin}\right)$$

Where

Ps = Points scored for price of tender under consideration

Pt = Rand Value of tender under consideration

Pmin = Rand value of lowest acceptable tender

**The 20 points of the Scoring System**

**Determination of Scores**

The allocation of preferential points is based on the B-BBEE Level of Contribution as given in the respective current and valid B-BBEE Certificate:

Preferential Points System – 80/20

B-BBEE Contribution Level of Contributor	No. Of Points as per Score Card
1	20
2	18
3	14
4	12
5	8
6	6
7	4
8	2
Non – Compliant Contributor	0

**F.3.16 Notification to unsuccessful tenderers**

If the Municipality’s Bid Adjudication Committee has resolved that a tender be accepted, the unsuccessful tenderers shall be notified in writing.

Any Tenderer wishing to exercise their right to appeal must submit their appeal in writing within 14 calendar days of publication of the *Intention to Award*. For the appeal to be considered, it must reach the municipality within the fourteen-day appeals period and be addressed to the Municipal Manager. Moreover, the appeal must be copied to the Supply Chain Manager and adhere to the following format:

- Clearly set out the reasons for the appeal,
- Clearly state in which way the appellant’s rights have been affected by the decision,
- Clearly state the relief or remedy sought by the appellant, and
- be accompanied by a copy of the *Intention to Award* or notification advising the Tenderer of the decision of the Municipality.

If no *bona fide* appeals have been received within the appeals period, the successful Tenderer will be notified of the Municipality’s acceptance of their bid.

The consideration of appeals and, if necessary, the invalidation of any decision made, shall be dealt with in terms of Municipality’s appeals process.

**F.3.17 Provide Copies of the Contracts**

“The number of paper copies of the signed contract to be provided by the Employer is ONE.”

**T1.2.3 Additional Conditions of Tender**

The additional conditions of tender are:

<b>T.1.2.3.1</b>	<p><b>Compliance with Occupational Health and Safety Act 1993 and Construction Regulations (as amended 2014) and any issued Covid – 19 regulations in terms of disaster management act</b></p> <p>Tenderers are to note the requirements of the Occupational Health and Safety Act No. 85 of 1993 and the latest amended Construction Regulations (2014) issued in terms of Section 43 of the Act. The Tenderer shall be deemed to have read and fully understood the requirements of the above Act and Regulations and to have allowed for all costs in compliance therewith.</p>
	<p>In this regard the Tenderer shall submit with the tender, appended to Health and Safety Plan in T2.2 Returnable Documents, a detailed Health and Safety Plan prepared in accordance with the Health and Safety Specification (given in in respect of the Works in order to demonstrate the necessary competencies and resources to perform the construction work all in accordance with the Act and Regulations).</p>
<b>T.1.2.3.2</b>	<p><b>T.1.2.3.2 Claims Arising after Submission of Tender</b></p>
	<p>No claim for any extras arising out of any doubt or obscurity as to the true intent and meaning of anything shown on the Contract Drawings or contained in the Conditions of Contract, Scope of Work and Pricing Data, will be admitted by the Employer/Employer’s Implementing Agent after the submission of any tender and the Tenderer shall be deemed to have:</p> <ol style="list-style-type: none"> <li>1) Inspected the Tender Drawings and read and fully understood the Conditions of Contract.</li> <li>2) Read and fully understood the whole text of the Scope of Work and Pricing Data and thoroughly acquainted himself with the nature of the works proposed and generally of all matters which may influence the Contract.</li> <li>3) Visited the site of the proposed works, carefully examined existing conditions, the means of access to the site, the conditions under which the work is to be done, and acquainted himself with any limitations or restrictions that may be imposed by the Municipal or other Authorities in regard to access and transport of materials and plant to and from the site and made the necessary provisions for any additional costs involved thereby.</li> <li>4) requested the Employer or his duly authorised agent to make clear the actual requirements of anything shown on the Tender Drawings or anything contained in the Scope of Work and Pricing Data, the exact meaning or interpretation of which is not clearly intelligible to the Tenderer.</li> </ol> <p>Before submission of any tender, the Tenderer should check the number of pages, and if any are found to be missing or duplicated, or the figures or writing indistinct, or if the Pricing Data contain any obvious errors, the Tenderer must apply to the Employer/Employer’s Implementing Agent at once to have the same rectified, as no liability will be admitted by the Employer/Employer’s Implementing Agent in respect of errors in any tender due to the foregoing.</p>
<b>T.1.2.3.3</b>	<p><b>Imbalance in Tendered Rates</b></p>
	<p>In the event of tendered rates or lump sums being declared by the Employer to be unacceptable to it because they are either excessively low or high or not in proper Balance with other rates or lump sums, the Tenderer may be required to produce evidence and advance arguments in support of the tendered rates or lump sums objected to. If, after submission of such evidence and any further evidence requested, the Employer is still not satisfied with the tendered rates or lump sums objected to, it may request the Tenderer to amend these rates and lump sums along the lines indicated by it.</p> <p>The Tenderer will then have the option to alter and/or amend the rates and lump sums objected to and such other related amounts as are agreed on by the Employer, but this shall be done without altering the Contract Price. Should the Tenderer fail to amend the Tender in a manner acceptable to the Employer, the Employer may reject the Tender.</p>
<b>T.1.2.3.4</b>	<p><b>Community Liaison Officer</b></p>

	<p>Democratically elected project area members who in turn have representation on the overall Project Steering Committee (PSC) represents the residents being served by the project. The Contractor will be required to liaise through the CLO for any matters to do with the community. The CLO shall be paid an amount of <b>R4 600</b> per month for the duration of contract.</p>
<b>T.1.2.3.5</b>	<b>Labour Intensive Construction / Use of Local Labour</b>
	<p>Aspects of this project will be carried out in accordance with the provisions of EPWP and as set out in clauses F.2.1.3 and F.2.1.4.</p> <p>The contractor must make use of local labour in order to promote labour intensive construction, the labour intensive works to be done under the contract is as stated below:</p> <ul style="list-style-type: none"><li>• Pipe Excavations (existing services i.e., stormwater, sewer, water, etc.)</li><li>• Backfilling</li><li>• Traffic controller</li><li>• Clearing of verges</li><li>• Kerbing and channeling</li></ul> <p>Recruitment of labour will be done in accordance with the DR NKOSAZANA DLAMINI-ZUMA Municipality's EPWP Recruitment Guidelines. The latest gazetted government labour rate for the Construction industry will to be used in the contract for remuneration of local labour.</p>

## TABLE OF CONTENTS

	<b>PAGE NO.</b>
T2: RETURNABLE DOCUMENTS AND SCHEDULES.....	RD. 2
T2.1: LIST OF RETURNABLE DOCUMENTS .....	RD. 2
T2.2: LIST OF RETURNABLE SCHEDULES AND FORMS.....	RD. 29

## T2: RETURNABLE DOCUMENTS AND SCHEDULES

### T2.1: LIST OF RETURNABLE DOCUMENTS

The tenderer must complete and return documents all returnable document as listed below as part of his/her tender submission:

Form	Returnable Schedules (Documents) for Tender Evaluation Purposes	Submitted Yes/No	Compulsory for Immediate Disqualification (Yes/No)
A1	Certificate of Tax Clearance (MBD 2)		Yes
A2	Company / Cc / Partnership / JV / SP Registration Certificates and Certified ID copies of ALL directors, members and partners.		Yes
A3	Certificate of attendance of Site Inspection Meeting		Yes
A4	PPP Document		Yes
A5	Declaration of Interest		Yes
A6	Preference Points claim form in terms of the Preferential Procurement Regulations 2011 (MBD 6.1)		Yes
A6.1	Declaration certificate for local production and content (MBD 6.2) and annexure C		Yes
A7	Certified BBBEE Certificate		No
A8	Rates Clearance Certificate		No
A9	Contractor's CIDB Registration Certificate		Yes
A10	Central Supplier's Database registration certificate		Yes
A11	Letter of Good Standing with Compensation Fund (COID)		Yes
A12	Declaration of Bidder's Past SCM (MBD 8)		Yes
A13	Independent Bid Determination (MBD 9)		Yes
A14	Record of Addenda to Tender Documents		Yes
A15	Contractor's Health and Safety Declaration (Form concerning fulfilment of the Construction Regulations, 2014)		Yes

**Note:** Compulsory for immediate disqualification means – the tender will not be evaluated further if a particular returnable schedule document is not duly completed and signed prior submitting bid document.



**A1: CERTIFICATE OF TAX CLEARANCE (MBD 2)**

Tenderers are required to be registered for VAT and will need to submit the following in order to be considered: -

- A SARS Tax Compliance Certificate **or**
- A Tax Compliance Status Certificate with Pin (Obtainable from E-Filing)

The tax clearance certificate as per the above must be valid prior to the closing date of the tender and must be kept valid for the duration of the contract.

**ATTACH PROOF TO THIS PAGE**

**A2: COMPANY / CC / PARTNERSHIP / JV / SP REGISTRATION CERTIFICATES**

*[NOTE: Registration Certificates for Companies, Close Corporations and Partnerships, or JV Agreements and Powers of Attorney for Joint Ventures, or ID documents for Sole Proprietors must be attached here. Tenderers must include certified ID copies of all directors, members and partners]*

**In addition to the above, the tenderer must insert here certified copy of identity documents of directors**

**ATTACH PROOF TO THIS PAGE**

**A3: CERTIFICATE OF ATTENDANCE OF SITE INSPECTION MEETING**

**CONTRACT No.: PWBS- B035/22/23  
CONSTRUCTION OF CREIGHTON TOWN UPGRADE (PHASE 2)**

*(Please print)*

It is hereby CERTIFIED that I,..... *(name)*  
in my capacity as ..... and a duly authorized  
representative of ..... *(the TENDERER)*  
of *(address)*.....  
in the company of ..... *(the ENGINEER)*  
attended the official Site Inspection on ..... *(date)*  
for and on behalf of the above-named Tenderer.

I hereby further DECLARE that I am satisfied with the description of the Works and the explanations given by the above-named Engineer.

**Particulars of person(s) attending the meeting:**

Name: ..... Signature: .....

Capacity: .....

Name: ..... Signature: .....

Capacity: .....

**Attendance of the above person(s) at the meeting is confirmed by the Employer's representative, namely:**

Name: ..... Signature: .....

Capacity: ..... Date and Time: .....



*Municipality Date Stamp*

**A4: PREFERENTIAL PROCUREMENT AND DECLARATION OF INTEREST**

In terms of Section 16 of the Preferential Procurement Policy Framework Act Regulations 2002 (Act No.5 of 2000) it is a condition of this tender/quote that the successful tenderer's taxation payments must be in order or that suitable arrangements have been made with the Receiver of Revenue: South African Revenue Services to this end and to their satisfaction.

**SERVICE PROVIDER TO CHECK WITH THE SCM UNIT IF TAX CLEARANCE ON FILE IS UPDATED.**

**In cases of Consortiums, Joint Ventures or Partnerships each individual must submit the required Certificate aforementioned.**

**PARTICULARS OF TAXPAYER/TENDERER**

<b>Name of Taxpayer/tenderer</b>	
<b>Trade name (if applicable)</b>	
<b>Identification No. (if applicable)</b>	
<b>Co. or CC No. (if applicable)</b>	
<b>Income Tax Reference No.</b>	
<b>VAT Registration No.</b>	
<b>PAYE No. (if applicable)</b>	
<b>(Person completing form) Name</b>	
<b>Address</b>	
<b>Telephone/Cell phone No.</b>	
<b>CIDB No.</b>	

**PREFERENCE POINTS CLAIM FORM IN TERMS OF THE PREFERENTIAL PROCUREMENT REGULATIONS 2017**

This preference form must form part of all bids invited. It contains general information and serves as a claim form for preference points for Broad-Based Black Economic Empowerment (B-BBEE) Status Level of Contribution

**NB: BEFORE COMPLETING THIS FORM, BIDDERS MUST STUDY THE GENERAL CONDITIONS, DEFINITIONS AND DIRECTIVES APPLICABLE IN RESPECT OF B-BBEE, AS PRESCRIBED IN THE PREFERENTIAL PROCUREMENT REGULATIONS, 2017.**

**A5: DECLARATION OF INTEREST (MBD 4)**

1. No bid will be accepted from persons in the service of the state<sup>1</sup>.
1. Any person, having a kinship with persons in the service of the state, including a blood relationship, may make an offer or offers in terms of this invitation to bid. In view of possible allegations of favouritism, should the resulting bid, or part thereof, be awarded to persons connected with or related to persons in service of the state, it is required that the bidder or their authorised representative declare their position in relation to the evaluating/adjudicating authority.

3 In order to give effect to the above, the following questionnaire must be completed and submitted with the bid.

3.1 Full Name of bidder or his or her representative:.....

3.2 Identity Number: .....

3.3 Position occupied in the Company (director, trustee, hareholder<sup>2</sup>):.....

3.4 Company Registration Number: .....

3.5 Tax Reference Number:.....

3.6 VAT Registration Number: .....

3.7 The names of all directors / trustees / shareholders members, their individual identity numbers and state employee numbers must be indicated in paragraph 4 below.

3.8 Are you presently in the service of the state? **YES / NO**

3.8.1 If yes, furnish particulars. ....

.....

<sup>1</sup>MSCM Regulations: "in the service of the state" means to be –

- (a) a member of –
  - (i) any municipal council;
  - (ii) any provincial legislature; or
  - (iii) the national Assembly or the national Council of provinces;
- (b) a member of the board of directors of any municipal entity;
- (c) an official of any municipality or municipal entity;
- (d) an employee of any national or provincial department, national or provincial public entity or constitutional institution within the meaning of the Public Finance Management Act, 1999 (Act No.1 of 1999);
- (e) a member of the accounting authority of any national or provincial public entity; or
- (f) an employee of Parliament or a provincial legislature.

<sup>2</sup> Shareholder" means a person who owns shares in the company and is actively involved in the management of the company or business and exercises control over the company.

3.9 Have you been in the service of the state for the past twelve months? .....**YES / NO**

3.9.1 If yes, furnish particulars.....

.....

3.10 Do you have any relationship (family, friend, other) with persons in the service of the state and who may be involved with the evaluation and or adjudication of this bid?.....**YES / NO**

3.10.1 If yes, furnish particulars.

.....  
.....

3.11 Are you, aware of any relationship (family, friend, other) between any other bidder and any persons in the service of the state who may be involved with the evaluation and or adjudication of this bid? **YES / NO**

3.11.1 If yes, furnish particulars  
 .....  
 .....

3.12 Are any of the company's directors, trustees, managers, principle shareholders or stakeholders in service of the state? **YES / NO**

3.12.1 If yes, furnish particulars.  
 .....  
 .....

3.13 Are any spouse, child or parent of the company's directors trustees, managers, principle shareholders or stakeholders in service of the state? **YES / NO**

3.13.1 If yes, furnish particulars.  
 .....  
 .....

3.14 Do you or any of the directors, trustees, managers, principle shareholders, or stakeholders of this company have any interest in any other related companies or business whether or not they are bidding for this contract. **YES / NO**

3.14.1 If yes, furnish particulars:  
 .....  
 .....

**4. Full details of directors / trustees / members / shareholders.**

Full Name	Identity Number	State Employee Number

.....  
**Signature**

.....  
**Date**

.....  
**Capacity**

.....  
**Name of Bidder**

**A6: PREFERENCE POINTS CLAIM FORM IN TERMS OF THE PREFERENTIAL PROCUREMENT  
 REGULATIONS 2011 WAS AMENDED TO ALIGN WITH NEW B-BBEE CODES OF GOOD PRACTICE  
 IN THE 2017 REGULATIONS  
 PURCHASES**

This preference form must form part of all bids invited. It contains general information and serves as a claim form for Broad Based Black Economic Empowerment (BBBEE) preference points.

**1. GENERAL CONDITIONS**

1.1 The following preference point systems are applicable to all bids:

- the 80/20 system for requirements with a Rand value of up to R50 000 000; and
- the 90/10 system for requirements with a Rand value above R50 000 000.

1.2 The value of this bid is estimated to exceed/not exceed R50 000 000 and therefore the 80/20 system shall be applicable.

1.3 Preference points for this bid shall be awarded for:

- (a) Price; and
- (b) Specific contract participation goals, as specified in the attached forms.

1.3.1 The points for this bid are allocated as follows:

B-BBEE Status Level of Contributor	Number of points (90/10 system)	Number of points (80/20 system)
1	10	20
2	9	18
3	6	14
4	5	12
5	4	8
6	3	6
7	2	4
8	1	2
Non-compliant contributor	0	0

1.4 Failure on the part of a bidder to fill in and/or to sign this form may be interpreted to mean that preference points are not claimed.

1.5 The purchaser reserves the right to require of a bidder, either before a bid is adjudicated or at any time subsequently, to substantiate any claim in regard to preferences, in any manner required by the purchaser.

**2. GENERAL DEFINITIONS**

**2.1 "Acceptable bid" means any bid which, in all respects, complies with the specifications and conditions of bid as set out in the bid document.**

**2.2 "Bid" means a written offer in a prescribed or stipulated form in response to an invitation by an organ of state for the provision of goods, works or services.**

**2.3 "Comparative price" means the price after the factors of a non-firm price and all**





$$P_s \left[ \frac{80}{100} \right] \left[ \frac{P_t - P_{min}}{P_{min}} \right] \quad \text{or} \quad P_s \left[ \frac{90}{100} \right] \left[ \frac{P_t - P_{min}}{P_{min}} \right]$$

Where

- Ps = Points scored for price of bid under consideration
- Pt = Rand value of bid under consideration
- Pmin = Rand value of lowest acceptable bid

- 6.2 Equity claims for a trust will only be allowed in respect of those persons who are both trustees and beneficiaries and who are actively involved in the management of the trust.
- 6.3 Documentation to substantiate the validity of the credentials of the trustees contemplated above must be submitted.
- 6.4 Listed companies and tertiary institutions do not qualify for HDI preference points.
- 6.5 A consortium or joint venture may, based on the percentage of the contract value managed or executed by each entity, to be entitled to preference points in respect of BEE.
- 6.6 A person awarded a contract as a result of preference for contracting with, may not subcontract more than 25% of the value of the contract to a person who is not an BEE compliant or does not qualify for the same number or more preference for BEE.

**7. BID DECLARATION**

- 7.1 Bidders who claim points in respect of BEE must complete the Bid Declaration at the end of this form.

**8. DESCRIBE PRINCIPAL BUSINESS ACTIVITIES**

---



---

**9. COMPANY CLASSIFICATION**

- Manufacturer
- Supplier
- Professional service provider
- Other service providers, e.g. transporter, etc.

[TICK APPLICABLE BOX]

**10. MUNICIPAL INFORMATION  
 (DISTRICT MUNICIPALITY ACCOUNT) \*WATER AND SANITATION ACCOUNT**

District Municipality where business is situated: .....

Registered Account No: .....

Stand No: .....

**(LOCAL MUNICIPALITY ACCOUNT) \*RATES, REFUSE, ELECTRICITY ACCOUNTS**

Local Municipality where business is situated: .....

Registered Account No: .....

Stand No: .....

**11 TOTAL NUMBER OF YEARS THE FIRM HAS BEEN IN BUSINESS?**  
 .....

**12 Consortium / Joint Venture**

**12.1** In the event that preference points are claimed for BEE members by consortia / joint ventures, the following information must be furnished in order to be entitled to the points claimed in respect of the HDI member:

Name of joint venture or consortium partner (to be consistent with paragraph 9.8)	Percentage (%) of the contract value managed or executed by the Joint Venture or Consortium partner

**12.2** I/we, the undersigned, who warrants that he/she is duly authorised to do so on behalf of the firm certify that points claimed, based on the BEE status, indicated in paragraph 8 of the foregoing certificate, qualifies the firm for the preference(s) shown and I / we acknowledge that:

- (i) The information furnished is true and correct.
- (ii) The BEE status claimed is in accordance with the General Conditions as indicated in paragraph 1 of this form.
- (iii) In the event of a contract being awarded as a result of points claimed as shown in paragraph 8, the contractor may be required to furnish documentary proof to the satisfaction of the purchaser that the claims are correct.
- (iv) If the claims are found to be incorrect, the purchaser may, in addition to any other remedy it may have -
  - (a) recover costs, losses or damages it has incurred or suffered as a result of that person's conduct; and
  - (b) cancel the contract and claim any damages which it has suffered as a result of having to make less favourable arrangements due to such cancellation;

**WITNESSES:**

- 1. ....
- 2. ....

.....  
 Signature(s) of bidders

## MBD 6.2: DECLARATION CERTIFICATE FOR LOCAL PRODUCTION AND CONTENT

This Municipal Bidding Document (MBD) must form part of all bids invited. It contains general information and serves as a declaration form for local content (local production and local content are used interchangeably).

Before completing this declaration, bidders must study the General Conditions, Definitions, Directives applicable in respect of Local Content as prescribed in the Preferential Procurement Regulations, 2011 and the South African Bureau of Standards (SABS) approved technical specification number SATS 1286:201x.

### 1. General Conditions

- 1.1. Preferential Procurement Regulations, 2011 (Regulation 9.(1) and 9.(3) make provision for the promotion of local production and content.
- 1.2. Regulation 9.(1) prescribes that in the case of designated sectors, where in the award of bids local production and content is of critical importance, such bids must be advertised with the specific bidding condition that only locally produced goods, services or works or locally manufactured goods, with a stipulated minimum threshold for local production and content will be considered.
- 1.3. Regulation 9.(3) prescribes that where there is no designated sector, a specific bidding condition may be included, that only locally produced services, works or goods or locally manufactured goods with a stipulated minimum threshold for local production and content, will be considered.
- 1.4. Where necessary, for bids referred to in paragraphs 1.2 and 1.3 above, a two stage bidding process may be followed, where the first stage involves a minimum threshold for local production and content and the second stage price and B-BBEE.
- 1.5. A person awarded a contract in relation to a designated sector, may not sub-contract in such a manner that the local production and content of the overall value of the contract is reduced to below the stipulated minimum threshold.
- 1.6. The local content (LC) as a percentage of the bid price must be calculated in accordance with the SABS approved technical specification number SATS 1286: 201x as follows:

$$LC = 1 - \left( \frac{x}{y} \right) \times 100$$

Where

- x imported content  
y bid price excluding value added tax (VAT)

Prices referred to in the determination of x must be converted to Rand (ZAR) by using the exchange rate published by the South African Reserve Bank (SARB) at 12:00 on the date, one week (7 calendar days) prior to the closing date of the bid as required in paragraph 4.1 below.

- 1.7. A bid will be disqualified if:
  - the bidder fails to achieve the stipulated minimum threshold for local production and content indicated in paragraph 3 below; and
  - this declaration certificate is not submitted as part of the bid documentation.

### 2. Definitions

- 2.1. **“bid”** includes advertised competitive bids, written price quotations or proposals;
- 2.2. **“bid price”** price offered by the bidder, excluding value added tax (VAT);
- 2.3. **“contract”** means the agreement that results from the acceptance of a bid by an organ of state;
- 2.4. **“designated sector”** means a sector, sub-sector or industry that has been designated by the Department of Trade and Industry in line with national development and industrial policies for local production, where only locally produced services, works or goods or locally manufactured goods meet the stipulated minimum threshold for local production and content;
- 2.5. **“duly sign”** means a Declaration Certificate for Local Content that has been signed by the Chief Financial Officer or other legally responsible person nominated in writing by the Chief Executive, or senior member / person with management responsibility (close corporation, partnership or individual).

- 2.6. **“imported content”** means that portion of the bid price represented by the cost of components, parts or materials which have been or are still to be imported (whether by the supplier or its subcontractors) and which costs are inclusive of the costs abroad, plus freight and other direct importation costs, such as landing costs, dock duties, import duty, sales duty or other similar tax or duty at the South African port of entry;
- 2.7. **“local content”** means that portion of the bid price which is not included in the imported content, provided that local manufacture does take place;
- 2.8. **“stipulated minimum threshold”** means that portion of local production and content as determined by the Department of Trade and Industry; and
- 2.9. **“sub-contract”** means the primary contractor’s assigning, leasing, making out work to, or employing another person to support such primary contractor in the execution of part of a project in terms of the contract.
3. **The stipulated minimum threshold(s) for local production and content for this bid is/are as follows:**

<u>Description of services, works or goods</u>	<u>Stipulated minimum threshold</u>
• <b>Steel value added products</b>	
o Gabions	100%
o Reinforcement	100%
o Steel Plates (Road signs)	100%
• <b>Cement products</b>	<b>100%</b>
• <b>Clothing and Textile</b>	<b>100%</b>
• <b>Electrical Steel Pole</b>	<b>100%</b>
• <b>Electrical Cable</b>	<b>100%</b>

4. Does any portion of the services, works or goods offered have any imported content? **YES / NO**
- 4.1 If yes, the rate(s) of exchange to be used in this bid to calculate the local content as prescribed in paragraph 1.6 of the general conditions must be the rate(s) published by the SARB for the specific currency at 12:00 on the date, one week (7 calendar days) prior to the closing date of the bid.

The relevant rates of exchange information is accessible on [www.reservebank.co.za](http://www.reservebank.co.za).

Indicate the rate(s) of exchange against the appropriate currency in the table below:

<b>Currency</b>	<b>Rates of exchange</b>
US Dollar	
Pound Sterling	
Euro	
Yen	
Other	

NB: Bidders must submit proof of the SARB rate (s) of exchange used.

**LOCAL CONTENT DECLARATION BY CHIEF FINANCIAL OFFICER OR OTHER LEGALLY RESPONSIBLE PERSON NOMINATED IN WRITING BY THE CHIEF EXECUTIVE OR SENIOR MEMBER/PERSON WITH MANAGEMENT RESPONSIBILITY (CLOSE CORPORATION, PARTNERSHIP OR INDIVIDUAL)**

**IN RESPECT OF BID No.** .....

**ISSUED BY:** (Procurement Authority / Name of Municipality / Municipal Entity):  
 .....

NB The obligation to complete, duly sign and submit this declaration cannot be transferred to an external authorized representative, auditor or any other third party acting on behalf of the bidder.

I, the undersigned, .....(full names),  
 do hereby declare, in my capacity as .....  
 of.....(name of bidder entity), the following:

- (a) The facts contained herein are within my own personal knowledge.
- (b) I have satisfied myself that the goods/services/works to be delivered in terms of the above-specified bid comply with the minimum local content requirements as specified in the bid, and as measured in terms of SATS 1286.
- (c) The local content has been calculated using the formula given in clause 3 of SATS 1286, the rates of exchange indicated in paragraph 4.1 above and the following figures:

Bid price, excluding VAT (y)	R
Imported content (x)	R
Stipulated minimum threshold for Local content (paragraph 3 above)	
Local content % as calculated in terms of SATS 1286	

If the bid is for more than one product, a schedule of the local content by product shall be attached.

(d) I accept that the Procurement Authority / Municipality /Municipal Entity has the right to request that the local content be verified in terms of the requirements of SATS 1286.

(e) I understand that the awarding of the bid is dependent on the accuracy of the information furnished in this application. I also understand that the submission of incorrect data, or data that are not verifiable as described in SATS 1286, may result in the Procurement Authority / Municipal / Municipal Entity imposing any or all of the remedies as provided for in Regulation 13 of the Preferential Procurement Regulations, 2011 promulgated under the Policy Framework Act (PPFA), 2000 (Act No. 5 of 2000).

**SIGNATURE:** \_\_\_\_\_

**DATE:** \_\_\_\_\_

**WITNESS No. 1** \_\_\_\_\_

**DATE:** \_\_\_\_\_

**WITNESS No. 2** \_\_\_\_\_

**DATE:** \_\_\_\_\_



## Annex D

### Imported Content Declaration - Supporting Schedule to Annex C

(D1) Tender No. \_\_\_\_\_  
 (D2) Tender description: \_\_\_\_\_  
 (D3) Designated Products: \_\_\_\_\_  
 (D4) Tender Authority: \_\_\_\_\_  
 (D5) Tendering Entity name: \_\_\_\_\_  
 (D6) Tender Exchange Rate: Pula \_\_\_\_\_

Note: VAT to be excluded from all calculations

EU R 9.00      GBP R 12.00

#### A. Exempted imported content

Calculation of imported content										Summary	
Tender item no's	Description of imported content	Local supplier	Overseas Supplier	Foreign currency value as per Commercial Invoice	Tender Exchange Rate	Local value of imports	Freight costs to port of entry	All locally incurred landing costs & duties	Total landed cost excl VAT	Tender Qty	Exempted imported value
(D7)	(D8)	(D9)	(D10)	(D11)	(D12)	(D13)	(D14)	(D15)	(D16)	(D17)	(D18)
(D19) Total exempt imported value										R 0	

This total must correspond with Annex C - C 21

#### B. Imported directly by the Tenderer

Calculation of imported content										Summary	
Tender item no's	Description of imported content	Unit of measure	Overseas Supplier	Foreign currency value as per Commercial Invoice	Tender Rate of Exchange	Local value of imports	Freight costs to port of entry	All locally incurred landing costs & duties	Total landed cost excl VAT	Tender Qty	Total imported value
(D20)	(D21)	(D22)	(D23)	(D24)	(D25)	(D26)	(D27)	(D28)	(D29)	(D30)	(D31)
(D32) Total imported value by tenderer											

#### C. Imported by a 3rd party and supplied to the Tenderer

Calculation of imported content										Summary	
Description of imported content	Unit of measure	Local supplier	Overseas Supplier	Foreign currency value as per Commercial Invoice	Tender Rate of Exchange	Local value of imports	Freight costs to port of entry	All locally incurred landing costs & duties	Total landed cost excl VAT	Quantity imported	Total imported value
(D33)	(D34)	(D35)	(D36)	(D37)	(D38)	(D39)	(D40)	(D41)	(D42)	(D43)	(D44)
(D45) Total imported value by 3rd party											

#### D. Other foreign currency payments

Calculation of foreign currency payments					Summary of payments
Type of payment	Local supplier making the payment	Overseas beneficiary	Foreign currency value paid	Tender Rate of Exchange	Local value of payments
(D46)	(D47)	(D48)	(D49)	(D50)	(D51)
(D52) Total of foreign currency payments declared by tenderer and/or 3rd party					

Signature of tenderer from Annex B \_\_\_\_\_

Date: \_\_\_\_\_

(D53) Total of imported content & foreign currency payments - (D32), (D45) & (D52) above \_\_\_\_\_

This total must correspond with Annex C - C 23

## Annex E

### Local Content Declaration - Supporting Schedule to Annex C

(E1)	Tender No.	<input style="width: 95%;" type="text"/>
(E2)	Tender description:	<input style="width: 95%;" type="text"/>
(E3)	Designated products:	<input style="width: 95%;" type="text"/>
(E4)	Tender Authority:	<input style="width: 95%;" type="text"/>
(E5)	Tendering Entity name:	<input style="width: 95%;" type="text"/>

**Note:** VAT to be excluded from all calculations

Local Products (Goods, Services and Works)	Description of items purchased	Local suppliers	Value
	(E6)	(E7)	(E8)
<b>(E9) Total local products (Goods, Services and Works)</b>			

(E10) **Manpower costs** (Tenderer's manpower cost)

(E11) **Factory overheads** (Rental, depreciation & amortisation, utility costs, consumables etc.)

(E12) **Administration overheads and mark-up** (Marketing, insurance, financing, interest etc.)

**(E13) Total local content**

**This total must correspond with Annex C - C24**

Signature of tenderer from Annex B \_\_\_\_\_

Date: \_\_\_\_\_



**A7: CERTIFIED B-BBEE CERTIFICATE**

Attach certified copy (not a copy of a copy) of B-BBEE Verification Certificate from a Verification Agency accredited by the South African Accreditation System (SANAS) or a Registered Auditor approved by the Independent Regulatory Board of Auditors (IRBA) or an Accounting Officer as contemplated in the Close Corporation Act (CCA) to this page.

## **A8: RATES AND MUNICIPAL SERVICES CLEARANCE CERTIFICATE**

In terms of Clause 38 of the Supply Chain Management Policy the Dr Nkosazana Dlamini Zuma Local Municipality reserves the right to reject any tender if any municipal rates and tariffs or municipal service charges owed by that tenderer or any of its directors to the municipality or to any other municipality or municipal entity are in arrears for more than 3 (three) months.

Tenderers are required to submit proof of payment of municipal rates and tariffs for the municipality in which the tender is being undertaken **and the** municipality in which their business address is recorded as per Companies and Intellectual Commission (CPIC) if different.

**SCM certificates for the Dr Nkosazana Dlamini Zuma area are obtainable from the Dr Nkosazana Dlamini Zuma Municipality and the provision of this certificate is compulsory;**

This serves to confirm that **my municipal rates and taxes are paid up to date and the following is attached:**

1. An copy of the most recent municipal statement not older than 3 months, indicating the status of payment of all municipal accounts and taxes, electricity, water, refuse, rates and levies, from the Municipality in which jurisdiction it's business is situated or;
2. In the case where the tenderer does not own property/is a tenant for the purpose of its business establishment, the tenderer to provide copy of lease agreement and a recent statement from its landlord certifying that all the tenants payments in respect of all municipal accounts and taxes i.e. electricity, water, refuse, rates and levies are paid up to date or;
3. In a case where the Service Provider cannot supply any of the above. The person would have to obtain a Rate Clearance Certificate from the Municipality that the person resides in. Service Provider would need a certified copy of the ID of all Directors and a certified copy of the company's CK Tendering, to obtain a certificate ; or
4. Tenders who are **not** registered with any municipality for the payment of rates and services due to their location may submit proof of residence / business address certified by a Municipal Councillor, but only if the residence is the same address as the business address; and

**In addition to 1 – 4 above, the following is compulsory**

5. SCM certificates for the Dr Nkosazana Dlamini Zuma area which are obtainable from the municipality and the provision of this Certificate is compulsory and must be attached to this page

**Attach proof to this page in terms of the above**

**A9: CONTRACTOR'S CIDB REGISTRATION CERTIFICATE**

*[The Tenderer shall attach the Proof of Registration with CIDB here].*

**IT IS THE CONTRACTOR'S RESPONSIBILITY TO ENSURE THAT THEIR ONLINE CIDB REGISTER OF CONTRACTORS REFLECTS THEM AS "ACTIVE" FOR THE DURATION OF THE TENDER VALIDITY PERIOD. AN "INACTIVE" REGISTRATION STATUS WILL INVALIDATE THE TENDER**

**A10: CENTRAL SUPPLIER'S DATABASE REGISTRATION CERTIFICATE**

*[The Tenderer shall attach the Proof of Registration with CSD here].*

**ATTACH PROOF HERE**

**FAILURE TO SUBMIT THIS RETURNABLE DOCUMENT WILL INVALIDATE THE TENDER**

**A11: LETTER OF GOOD STANDING WITH COMPENSATION FUND (COID)**

*[NOTE: The tenderer's Workmen's Compensation Registration Certificate in accordance to the Compensation for Occupational Injuries and Diseases Act No. 130 of 1993, is to be attached here].*

**ATTACH PROOF HERE**

**FAILURE TO SUBMIT THIS RETURNABLE DOCUMENT WILL INVALIDATE THE TENDER**

## A12: DECLARATION OF TENDERER'S PAST SUPPLY CHAIN MANAGEMENT PRACTICES (MBD 8)

- 1 This Municipal Bidding Document must form part of all bids invited.
- 2 It serves as a declaration to be used by municipalities and municipal entities in ensuring that when goods and services are being procured, all reasonable steps are taken to combat the abuse of the supply chain management system.
- 3 The bid of any TENDERER may be rejected if that TENDERER, or any of its directors have:
  - a. abused the municipality's / municipal entity's supply chain management system or committed any improper conduct in relation to such system;
  - b. been convicted for fraud or corruption during the past five years;
  - c. willfully neglected, reneged on or failed to comply with any government, municipal or other public sector contract during the past five years; or
  - d. been listed in the Register for Tender Defaulters in terms of section 29 of the Prevention and Combating of Corrupt Activities Act (No 12 of 2004).
- 4 **In order to give effect to the above, the following questionnaire must be completed and submitted with the bid.**

Item	Question	Yes	No
4.1	Is the TENDERER or any of its directors listed on the National Treasury's database as a company or person prohibited from doing business with the public sector? <b>(Companies or persons who are listed on this database were informed in writing of this restriction by the National Treasury after the <i>audi alteram partem</i> rule was applied).</b>	Yes <input type="checkbox"/>	No <input type="checkbox"/>
4.1.1	If so, furnish particulars:		
4.2	Is the TENDERER or any of its directors listed on the Register for Tender Defaulters in terms of section 29 of the Prevention and Combating of Corrupt Activities Act (No 12 of 2004)? <b>(To access this Register enter the National Treasury's website, <a href="http://www.treasury.gov.za">www.treasury.gov.za</a>, click on the icon "Register for Tender Defaulters" or submit your written request for a hard copy of the Register to facsimile number (012) 3265445).</b>	Yes <input type="checkbox"/>	No <input type="checkbox"/>
4.2.1	If so, furnish particulars:		
4.3	Was the TENDERER or any of its directors convicted by a court of law (including a court of law outside the Republic of South Africa) for fraud or corruption during the past five years?	Yes <input type="checkbox"/>	No <input type="checkbox"/>
4.3.1	If so, furnish particulars:		
Item	Question	Yes	No
4.4	Does the TENDERER or any of its directors owe any municipal rates and taxes or municipal charges to the municipality / municipal entity, or to any other municipality / municipal entity, that is in arrears for more than three months?	Yes <input type="checkbox"/>	No <input type="checkbox"/>

4.4.1	If so, furnish particulars:		
4.5	Was any contract between the TENDERER and the municipality / municipal entity or any other organ of state terminated during the past five years on account of failure to perform on or comply with the contract?	Yes <input type="checkbox"/>	No <input type="checkbox"/>
4.7.1	If so, furnish particulars:		

**CERTIFICATION**

**I, THE UNDERSIGNED (FULL NAME) .....CERTIFY THAT THE INFORMATION FURNISHED ON THIS DECLARATION FORM TRUE AND CORRECT.**

**I ACCEPT THAT, IN ADDITION TO CANCELLATION OF A CONTRACT, ACTION MAY BE TAKEN AGAINST ME SHOULD THIS DECLARATION PROVE TO BE FALSE.**

.....  
 SIGNATURE

.....  
 DATE

.....  
 POSITION

.....  
 NAME OF TENDERER

---

**A13: CERTIFICATE OF INDEPENDENT BID DETERMINATION (MBD 9)**

- 1 This Municipal Bidding Document (MBD) must form part of all bids<sup>1</sup> invited.
  
- 2 Section 4 (1) (b) (iii) of the Competition Act No. 89 of 1998, as amended, prohibits an agreement between, or concerted practice by, firms, or a decision by an association of firms, if it is between parties in a horizontal relationship and if it involves collusive bidding (or bid rigging).<sup>2</sup> Collusive bidding is a *pe se* prohibition meaning that it cannot be justified under any grounds.
  
- 3 Municipal Supply Regulation 38 (1) prescribes that a supply chain management policy must provide measures for the combating of abuse of the supply chain management system, and must enable the accounting officer, among others, to:
  - a. take all reasonable steps to prevent such abuse;
  - b. reject the bid of any TENDERER if that TENDERER or any of its directors has abused the supply chain management system of the municipality or municipal entity or has committed any improper conduct in relation to such system; and
  - c. cancel a contract awarded to a person if the person committed any corrupt or fraudulent act during the bidding process or the execution of the contract.
  
- 4 This MBD serves as a certificate of declaration that would be used by institutions to ensure that, when bids are considered, reasonable steps are taken to prevent any form of bid-rigging.
  
- 5 In order to give effect to the above, the attached Certificate of Bid Determination (MBD 9) must be completed and submitted with the bid:

<sup>1</sup> Includes price quotations, advertised competitive bids, limited bids and proposals.

<sup>2</sup> Bid rigging (or collusive bidding) occurs when businesses, that would otherwise be expected to compete, secretly conspire to raise prices or lower the quality of goods and / or services for purchasers who wish to acquire goods and / or services through a bidding process. Bid rigging is, therefore, an agreement between competitors not to compete.



I, the undersigned, in submitting the accompanying bid:

**CONTRACT No.: B035/22/23**  
**CONSTRUCTION OF CREIGHTON TOWN UPGARDE (PHASE 2)**

in response to the invitation for the bid made by: **DR NKOSAZANA DLAMINI ZUMA LOCAL  
MUNICIPALITY**

do hereby make the following statements that I certify to be true and complete in every respect:

I certify, on behalf of: \_\_\_\_\_ that:

(Name of TENDERER)

1. I have read and I understand the contents of this Certificate;
2. I understand that the accompanying bid will be disqualified if this Certificate is found not to be true and complete in every respect;
3. I am authorized by the TENDERER to sign this Certificate, and to submit the accompanying bid, on behalf of the TENDERER;
4. Each person whose signature appears on the accompanying bid has been authorized by the TENDERER to determine the terms of, and to sign, the bid, on behalf of the TENDERER;
5. For the purposes of this Certificate and the accompanying bid, I understand that the word "competitor" shall include any individual or organization, other than the TENDERER, whether or not affiliated with the TENDERER, who:
  - (a) has been requested to submit a bid in response to this bid invitation;
  - (b) could potentially submit a bid in response to this bid invitation, based on their qualifications, abilities or experience; and
  - (c) provides the same goods and services as the TENDERER and/or is in the same line of business as the TENDERER
6. The TENDERER has arrived at the accompanying bid independently from, and without consultation, communication, agreement or arrangement with any competitor. However, communication between partners in a joint venture or consortium<sup>3</sup> will not be construed as collusive bidding.
7. In particular, without limiting the generality of paragraphs 6 above, there has been no consultation, communication, agreement or arrangement with any competitor regarding:
  - (a) prices;
  - (b) geographical area where product or service will be rendered (market allocation)
  - (c) methods, factors or formulas used to calculate prices;
  - (d) the intention or decision to submit or not to submit, a bid;
  - (e) the submission of a bid which does not meet the specifications and conditions of the bid; or
  - (f) bidding with the intention not to win the bid.

8. In addition, there have been no consultations, communications, agreements or arrangements with any competitor regarding the quality, quantity, specifications and conditions or delivery particulars of the products or services to which this bid invitation relates.
9. The terms of the accompanying bid have not been, and will not be, disclosed by the TENDERER, directly or indirectly, to any competitor, prior to the date and time of the official bid opening or of the awarding of the contract.
10. I am aware that, in addition and without prejudice to any other remedy provided to combat any restrictive practices related to bids and contracts, bids that are suspicious will be reported to the Competition Commission for investigation and possible imposition of administrative penalties in terms of section 59 of the Competition Act No 89 of 1998 and or may be reported to the National Prosecuting Authority (NPA) for criminal investigation and or may be restricted from conducting business with the public sector for a period not exceeding ten (10) years in terms of the Prevention and Combating of Corrupt Activities Act No 12 of 2004 or any other applicable legislation.

<sup>3</sup> Joint venture or Consortium means an association of persons for the purpose of combining their expertise, property, capital, efforts, skill and knowledge in an activity for the execution of a contract.

.....  
SIGNATURE

.....  
DATE

.....  
POSITION

.....  
NAME OF TENDERER

**A14: RECORD OF ADDENDA TO TENDER DOCUMENTS**

I / We confirm that the following communications received from the Employer or his representative before the date of submission of this tender offer, amending the tender documents, have been considered in this tender offer.

No.	Date	Title or Details
1		
2		
3		
4		
5		

NAME: .....

POSITION: .....

SIGNATURE: .....

DATE: .....

(of person authorised to sign on behalf of the Tenderer)

**A15: FORM CONCERNING FULFILMENT OF THE CONSTRUCTION REGULATIONS, 2014**

*[NOTE: this form must be completed concerning fulfilment of the construction regulations, 2014]*

In terms of Regulation 4(3) of the Construction Regulations, 2014 (hereinafter referred to as the Regulations), promulgated on 7 February 2014 in terms of Section 43 of the Occupational Health and Safety Act, 1993 (Act No 85 of 1993), the Employer shall not appoint a Contractor to perform construction work unless the Contractor can satisfy the Employer that his/her firm has the necessary competencies and resources to carry out the work safely and has allowed adequately in his/her Tender for the due fulfilment of all the applicable requirements of the Act and the Regulations.

- 1 I confirm that I am fully conversant with the Regulations and that my company has (or will acquire/procure) the necessary competencies and resources to timeously, safely and successfully comply with all of the requirements of the Regulations. (Tick)

YES	
NO	

- 2 Proposed approach to achieve compliance with the Regulations (Tick)

Own resources, competent in terms of the Regulations (refer to 3 below)	
Own resources, still to be hired and/or trained (until competency is achieved)	
Specialist subcontract resources (competent) - specify: ..... ..... ..... ..... ..... .....	

- 3 Provide details of proposed key persons, competent in terms of the Regulations, who will form part of the Contract team as specified in the Regulations (CVs to be attached):

.....  
.....  
.....  
.....  
.....  
.....

- 4 Provide details of proposed training (if any) that will be undergone:

.....  
.....  
.....  
.....  
.....  
.....

.....  
5 Potential key risks identified and measures for addressing risks:

.....  
.....  
.....  
.....  
.....  
.....  
.....  
.....

6 I have fully included in my tendered rates and prices (in the appropriate payment items provided in the Schedule of Quantities) for all resources, actions, training and any other costs required for the due fulfilment of the Regulations for the duration of the construction and defects repair period.(Tick)

YES	
NO	

7 The Tenderer shall attach to this Form evidence that he is registered and in good standing with a compensation insurer who is approved by Department of Labour in terms of section 80 of the Compensation for Injury and Disease Act, 1993 (Act No 130 of 1993)(COID).

The Tenderer is required to disclose, by also attaching documentary evidence to this form, all inspections, investigations and their outcomes conducted by the Department of Labour into the conduct of the Tenderer at any time during the 36 months preceding the date of this Tender.

SIGNATURE OF PERSON(S) AUTHORISED TO SIGN THIS TENDER:

1 ..... ID NO: .....  
2 ..... ID NO: .....

## T2.2: RETURNABLE SCHEDULES

The tenderer must complete and submit the following returnable schedules and documents:

Form	Returnable Schedules (Documents) that will be incorporated into the contract	Remarks
B1	Tenderer's Financial standing	For evaluation purposes
B2	Certificate of Authority for Signatory	Invalidate The Tender
B2.1	Certificate of Authority for Joint Ventures	Invalidate The Tender
B2.2	Joint Venture Disclosure Form	Invalidate The Tender
B3	Schedule of Current Commitments	For evaluation purposes
B4	Forms for Functionality points	For evaluation purposes
B4.1	Company Experience	For evaluation purposes
B4.2	Schedule of plant and equipment	For evaluation purposes
B4.3	Proposed Key personnel	For evaluation purposes
B4.4	Quality Control Plan	For evaluation purposes
B4.5	Compulsory subcontracting	Invalidate The Tender
B4.6	EPWP Requirements	For evaluation purposes
B5	Certificate for Insurance Cover	For evaluation purposes
B6	Preliminary Construction Programme	For evaluation purposes
B7	Estimated Monthly Expenditure	For evaluation purposes
B8	Compulsory Enterprise Questionnaire	Invalidate The Tender

**[NOTE: Each form must be completed fully the evaluation of tenders and the eventual contract will be based on the information provided by the Tenderer. Failure to complete the schedules and forms to the satisfaction of the Employer will, inevitably, prejudice the tender and may lead to rejection claiming the tender is not responsive].**

**B1: TENDERER'S FINANCIAL STANDING (FINANCIAL REFERENCES)**

**Financial Statements**

I/We agree, if required, to furnish an audited copy of the latest set of financial statements together with my/our Directors' and Auditors' report for consideration by the Employer.

**Details of Company's Bank**

I/We hereby authorise the Employer/Engineer to approach all or any of the following banks for the purposes of obtaining a financial reference:

<b>DESCRIPTION OF BANK DETAIL</b>	<b>BANK DETAILS APPLICABLE TO TENDERER'S HEAD OFFICE</b>
Name of bank	
Branch name	
Branch code	
Street address	
Postal address	
Name of manager	
Telephone number	
Fax number	
Account number	

**Tenderer's Tax Details**

Tenderer's VAT vendor registration number: .....

Tenderer's SARS tax reference number: .....

NAME: .....

POSITION: .....

SIGNATURE: .....

DATE: .....

(of person authorised to sign on behalf of the Tenderer)

**B2: CERTIFICATE OF AUTHORITY FOR SIGNATORY**

*Signatories for close corporations and companies shall confirm their authority by attaching to this form a duly signed and dated copy of the relevant resolution of their members or their board of directors, as the case may be.*

*An example for a company is shown below:*

"I/We\*, the undersigned, am/are\* duly authorised to sign the form of tender on behalf of

.....

by virtue of the Articles of Association/Resolution of the Board of Directors\*, of which a certified copy is attached, or

.....

.....

\*Delete whichever is inapplicable

**NAME**

**SIGNATURE**

**DATE**

**NAME**

**SIGNATURE**

**DATE**

**WITNESSES**

**NAME**

**SIGNATURE**

**DATE**

**NAME**

**SIGNATURE**

**DATE**



**B2.1: CERTIFICATE OR AUTHORITY FOR JOINT VENTURES**

This Returnable Schedule is to be completed only if Tenderer is a joint venture.

We, the undersigned, are submitting this tender offer in joint venture and hereby authorise

Mr/Ms....., authorised signatory of the company, close corporation or partnership..... acting in the capacity of lead partner, to sign all documents in connection with the tender offer and any contract resulting from it on our behalf.

NAME OF FIRM	ADDRESS	DULY AUTHORISED SIGNATORY
Lead partner		Signature : ..... Name : ..... Designation : .....
		Signature : ..... Name : ..... Designation : .....
		Signature : ..... Name : ..... Designation : .....
		Signature : ..... Name : ..... Designation : .....

**Note:**  
 A copy of the Joint Venture Agreement showing clearly the percentage contribution of each partner to the Joint Venture shall be appended to this Schedule.

**B2.2: JOINT VENTURE DISCLOSURE FORM**

**GENERAL**

- i. All the information requested must be filled in the spaces provided. If additional space is required, additional sheets may be used and attached to the original documents.
- ii. A copy of the joint venture agreement must be attached to this form, in order to demonstrate the Affirmable, Joint Venture Partner's share in the ownership, control, management responsibilities, risks and profits of the joint venture, the proposed joint venture agreement must include specific details relating to:
  - a. the contributions of capital and equipment
  - b. work items to be performed by the Affirmable Joint Venture Partner's own forces
  - c. work items to be performed under the supervision of the Affirmable Joint Venture Partner.
- iii. Copies of all written agreements between partners concerning the contract must be attached to this form including those, which relate to ownership options and to restrictions/limits regarding ownership and control.
- iv. ABE partners must complete ABE Declaration Affidavits.
- v. The joint venture must be formalised. All pages of the joint venture agreement must be signed by all the parties concerned. A letter/ notice of intention to formalise a joint venture once the contract has been awarded will not be considered.
- vi. Should any of the above not be complied with, the joint venture will be deemed null and void and will be considered non-responsive.

**1. JOINT VENTURE PARTICULARS**

- a) Name .....
- b) Postal address .....
- . .....
- . .....
- c) Physical address .....
- . .....
- . .....
- d) Telephone .....
- e) Fax .....

**2. IDENTITY OF EACH NON-AFFIRMABLE JOINT VENTURE PARTNER**

- 2.1(a) Name of Firm** .....
- Postal Address .....
- Physical Address .....
- Telephone .....
- Fax .....

Contact person for matters pertaining to Joint Venture Participation Goal requirements:  
.....

**2.2(a) Name of Firm** .....

Postal Address .....

Physical Address .....

Telephone .....

Fax .....

Contact person for matters pertaining to Joint Venture Participation Goal requirements:

.....  
*(Continue as required for further non-Affirmable Joint Venture Partners)*

**3. IDENTITY OF EACH AFFIRMABLE JOINT VENTURE PARTNER**

**3.1(a) Name of Firm** .....

Postal Address .....

Physical Address .....

Telephone .....

Fax .....

Contact person for matters pertaining to Joint Venture Participation Goal requirements:

**3.2(a) Name of Firm** .....

Postal Address .....

Physical Address .....

Telephone .....

Fax .....

Contact person for matters pertaining to Joint Venture Participation Goal requirements:

**3.3(a) Name of Firm** .....

Postal Address .....

Physical Address .....

Telephone .....

Fax .....

Contact person for matters pertaining to Joint Venture Participation Goal requirements:

**4. BRIEF DESCRIPTION OF THE ROLES OF THE AFFIRMABLE JOINT VENTURE PARTNERS IN THE JOINT VENTURE**

.....

.....  
 .....

**5. OWNERSHIP OF THE JOINT VENTURE**

a) Affirmable Joint Venture Partner ownership percentage(s) ..... %

b) Non-Affirmable Joint Venture Partner ownership percentage(s)..... %

c) Affirmable Joint Venture Partner percentages in respect of : \*

i) Profit and loss sharing .....

ii) Initial capital contribution in Rands .....

(\*Brief descriptions and further particulars should be provided to clarify percentages).

iii) Anticipated on-going capital contributions in Rands .....

iv) Contributions of equipment (specify types, quality, and quantities of equipment) to be provided by each partner.

.....  
 .....

**6. RECENT CONTRACTS EXECUTED BY PARTNERS IN THEIR OWN RIGHT AS PRIME CONTRACTORS OR AS PARTNERS IN OTHER JOINT VENTURES**

	NON-AFFIRMABLE JOINT VENTURE PARTNERS	PARTNER NAME
a.		
b.		
c.		
d.		
e.		

	AFFIRMABLE JOINT VENTURE PARTNERS	PARTNER NAME
a.		
b.		
c.		
d.		
e.		

---

**7. CONTROL AND PARTICIPATION IN THE JOINT VENTURE**

(Identify by name and firm those individuals who are, or will be, responsible for, and have authority to engage in the relevant management functions and policy and decision making, indicating any limitations in their authority e.g. co-signature requirements and Rand limits).

a) Joint Venture cheque signing

.....  
.....  
.....

b) Authority to enter into contracts on behalf of the Joint Venture

.....  
.....  
.....

c) Signing, co-signing and/or collateralising of loans

.....  
.....  
.....

d) Acquisition of lines of credit

.....  
.....  
.....

e) Acquisition of performance bonds

.....  
.....  
.....

f) Negotiating and signing labour agreements

.....  
.....  
.....

**8. MANAGEMENT OF CONTRACT PERFORMANCE**

(Fill in the name and firm of the responsible person).

a) Supervision of field operations

.....

b) Major purchasing

.....

c) Estimating

.....

d) Technical management

.....

**9. MANAGEMENT AND CONTROL OF JOINT VENTURE**

a) Identify the “managing partner”, if any,

.....

.....

.....

.....

b) What authority does each partner have to commit or obligate the other to financial institutions, insurance companies, suppliers, subcontractors and/or other parties participating in the execution of the contemplated works?

.....

.....

.....

.....

c) Describe the management structure for the Joint Venture’s work under the contract

MANAGEMENT FUNCTION / DESIGNATION	NAME	PARTNER*

(Fill in “ex Affirmable Joint Venture Partner” or “ex non-Affirmable Joint Venture Partner”.

**10. PERSONNEL**

- a) State the approximate number of operative personnel (by trade/function/discipline) needed to perform the Joint Venture work under the Contract.

TRADE/FUNCTION/DISCIPLINE	NUMBER EX AFFIRMABLE JOINT VENTURE PARTNERS	NUMBER EX NONAFFIRMABLE JOINT VENTURE PARTNERS

(Fill in "ex Affirmable Joint Venture Partner" or "ex non-Affirmable Joint Venture Partner").

- b) Number of operative personnel to be employed on the Contract who are currently in the employ of partners.

- (i) Number currently employed by Affirmable Joint Venture Partners

.....

- (ii) Number currently employed by the Joint Venture

.....

- c) Number of operative personnel who are not currently in the employ of the respective partner and will be engaged on the project by the Joint Venture

.....

- d) Name of individual(s) who will be responsible for hiring Joint Venture employees

.....

.....

- e) Name of partner who will be responsible for the preparation of Joint Venture payrolls

.....

.....

**11. CONTROL AND STRUCTURE OF THE JOINT VENTURE**

Briefly describe the manner in which the Joint Venture is structured and controlled.

.....

.....

.....  
The undersigned warrants that he/she is duly authorised to sign this Joint Venture Disclosure Form and affirms that the foregoing statements are true and correct and include all material information necessary to identify and explain the terms and operations of the Joint Venture and the intended participation of each partner in the undertaking.

The undersigned further covenants and agrees to provide the Employer with complete and accurate information regarding actual Joint Venture work and the payment therefore, and any proposed changes in any provisions of the Joint Venture agreement, and to permit the audit and examination of the books, records and files of the Joint Venture, or those of each partner relevant to the Joint Venture, by duly authorised representatives of the Employer.

Signature.....

Duly authorised to sign on behalf of .....

Name.....

Address.....

Telephone.....

Date.....

Signature.....

Duly authorised to sign on behalf of.....

Name.....

Address.....

Telephone.....

Date.....

Signature.....

Duly authorised to sign on behalf of.....

Name.....

Address.....

Telephone.....

Date.....

Signature.....

Duly authorised to sign on behalf of.....

Name.....

Address.....

Telephone.....

Date.....







**B4.2: SCHEDULE OF PLANT AND EQUIPMENT**

Each partner to a joint Venture is to provide the information required below with respect to his company's contribution to the plant and equipment resourcing of the Joint Venture.

The following are lists of major items of relevant equipment that I / we presently own or lease and will have available for this contract if my / our tender is accepted.

**(a) Details of major equipment that is owned by me / us and immediately available for this contract.**

DESCRIPTION (type, size, capacity etc.)	QUANTITY	YEAR OF MANUFACTURE

*Attach additional pages if more space is required*

**(b) Details of major equipment that will be hired, or acquired for this contract if my / our tender is accepted**

DESCRIPTION (type, size, capacity etc.)	QUANTITY	HOW ACQUIRED	
		HIRE/BUY	SOURCE

*Attach additional pages if more space is required*

The Tenderer undertakes to bring onto site without additional cost to the Employer any additional plant not listed but which may be necessary to complete the contract within the specified contract period.

NAME: ..... POSITION: .....

SIGNATURE: ..... DATE: .....

*(of person authorised to sign on behalf of the tenderer)*

**B4.3: PROPOSED KEY PERSONNEL**

The **Tenderer** shall enter in the table below information in respect of the key personnel who will be engaged on the project. Abbreviated Curricula Vitae, which specifically address the questions posed in the Point Scoring Check for Functionality, including the relevant certificates, to support the stated information must be included in the proposal together with a copy of this form. Form A3 will used to evaluate the functionality of the submission. An organogram and employee CV's need to be appended to this form

Designation	Name	Qualification	Years' Experience
Contract Manager			
Site Agent			
Foreman			

The Tenderer shall attach hereto the *curricula vitae*, in the form included hereafter, of at least the **project manager**, **site agent** and **foreman**. The information is necessary for evaluation of the tender.

SIGNATURE: .....

DATE: .....

*(of person authorised to sign on behalf of the Tenderer)*







#### **B4.4: QUALITY CONTROL PLAN**

*[The Tenderer shall attach the required document here.]*

The Quality Control Plan must detail the following to get full points:

1. Tenderer's proposed methodology for the works,
2. Health and safety management plan, and
3. Quality control measures (testing, inspections, technical query management and project reporting).
4. Contractor is certified as with the Quality Management System to ISO9001:2008 or 2015 standard and has attached a certified copy of the certification.

**(5 pages maximum)**

**Good:** Quality Control Plan lists and discusses the headings above and the contractor has a certified Quality Management System to ISO9001:2008 or 2015 standards.

**Acceptable:** Quality Control Plan lists and discusses **three** of the headings above.

**Fair:** Quality Control Plan lists and discusses less than three of the headings above.

**No submission:** Quality Control Plan is not related to the required information or is not submitted.

**FAILURE TO SUBMIT THIS DOCUMENT WILL RESULT IN NO POINTS BEING AWARDED**



**B4.5: COMPUSLORY SUBCONTRACTING (Pre-qualification)**

The tenderer must sub-contract a minimum of 30% of the contract value to EMEs or QSEs which are at least 51% owned by black people who are; women or youth or with disability. List of SMME local database is available on the municipal website([www.ndz.gov.za](http://www.ndz.gov.za)). Subcontract is not limited to one service provider.

I/We hereby notify you that it is my/our intention to employ the following subcontractors for work in this contract.

If I/we am/are awarded a contract I/we agree that this notification does not change the requirement for me/us to submit the names of proposed subcontractors in accordance with requirements of the contract for such appointments. If there are no such requirements in the contract, then your written acceptance of this list shall be binding between us.

**NB: Tender must include the following information for proposed Subcontractors**

CSD report, CIDB certificate or CIRS number and tax compliance status form

No	Name and Address of Proposed Subcontractor	Nature and Extent of Work	ESTIMATED AMOUNT TO BE SUBCONTRACTED
1.			
2.			
3.			
4.			
5.			
6.			
7.			

Signed .....

Date

Name .....

Position

Tenderer .....

**B4.6: EPWP Requirements**

**a. Schedule of Labour Content**

The tenderer must complete a standard table reflecting the labour force anticipated to be employed on this contract, including labour employed by sub-contractors. The Specified target value is..... %

Type of Labour	Man-Days	Minimum Wage Rate per unit	Total Wage Cost (Excl. VAT)
Permanent Staff			
Temporary Staff			
SMME/HDEs Labour			
Total			
Percentage			

**[NOTES:**

- (1) Labour is defined as hourly paid personal
- (2) The penalty for non-compliance during the contract or fraudulent disclosure is discussed in CONTRACT DATA section.]

**b. Name of Training Institution**

Name of Programme

Trainers Name	Qualification	Subject

**[Notes:**

- (1) Provide details here, or attached hereto, the subjects to be covered and the manner in which training is to be delivered.]

**B5: CERTIFICATE FOR INSURANCE COVER**

*[NOTE: In the event of the Tenderer being a joint venture/consortium, the details of the individual members must also be provided.]*

The Tenderer shall provide the following details of this insurance cover:

- i) Name of Tenderer: .....
- ii) Period of Validity: .....
- iii) Value of Insurance:
  - Insurance for Works and Contractor's equipment  
Company: .....  
Value: .....
  - Insurance for Contractor's personnel  
Company: .....  
Value: .....
  - General public liability  
Company: .....  
Value: .....
  - SASRIA  
Company: .....  
Value: .....

---

**B6: PRELIMINARY CONSTRUCTION PROGRAMME (FOR INFORMATION PURPOSES ONLY)**

The Tenderer shall attach a preliminary programme, to this Form.

This programme shall:

- be in the form of a bar chart (Gantt chart) or similar acceptable time/activity form reflecting the proposed sequence and tempo of execution of the various activities and the quantities that will be carried out every week under each of the elements, comprising the work for this contract;
- also indicate the point where the Tenderer intends to commence work operations and the direction in which the work will proceed;
- be in accordance with the information provided in Form C3.2: Schedule of plant and equipment, Form B5: Estimated monthly expenditure, and with all other aspects of the Tender; and
- indicate planned working hours.

*[NOTE: The programme must be based on the completion time as specified in the Contract Data. No other completion time that may be indicated on this programme will be regarded as an alternative offer, unless it is listed in Table (b) of Form I hereafter and supported by a detailed statement to that effect, all as specified in the Tender Data]*

NAME: .....

POSITION: .....

SIGNATURE: .....

DATE: .....

*(of person authorised to sign on behalf of the Tenderer)*

**B7 ESTIMATED MONTHLY EXPENDITURE**

The Tenderer shall state below the estimated value of work to be completed every month, based on his preliminary programme and his tendered unit rates.

The amount for contingencies must not be included.

MONTH	VALUE
1	R .....
2	R .....
3	R .....
4	R .....
5	R .....
6	R ..... ..... COMPLETION OF CONTRACT
TOTAL	R .....

NAME: .....

POSITION: .....

SIGNATURE: .....

DATE: .....

*(of person authorised to sign on behalf of the Tenderer)*

**B8: COMPULSORY ENTERPRISE QUESTIONNAIRE**

The following must be furnished; in the case of a joint venture, **separate** enterprise questionnaires in respect of each partner must be completed and submitted.

**Section 1: Name of enterprise:** .....

**Section 2: VAT registration number, if any:** .....

**Section 3: CIDB registration number, if any:** .....

**Section 4: Particulars of sole proprietors and partners in partnerships**

Name*	Identity number*	Personal income tax number*

\* Complete only if sole proprietor or partnership and attach separate page if more than 3 partners

**Section 5: Particulars of companies and close corporations**

Company registration number .....

Close corporation number .....

Tax reference number .....

**Section 6: Record of service of the state**

Indicate by marking the relevant boxes with a cross, if any sole proprietor, partner in a partnership or director, manager, principal shareholder or stakeholder in a company or close corporation is currently or has been within the last 12 months in the service of any of the following:

- |  |   |
|--|---|
| <input type="checkbox"/> a member of any municipal council                                     | <input type="checkbox"/> an employee of any provincial department, national or provincial public entity or constitutional institution within the meaning of the Public Finance Management Act, 1999 (Act 1 of 1999) |
| <input type="checkbox"/> a member of any provincial legislature                                | <input type="checkbox"/> a member of an accounting authority of any national or provincial public entity  |
| <input type="checkbox"/> a member of the National Assembly or the National Council of Province | <input type="checkbox"/> an employee of Parliament or a provincial legislature  |
| <input type="checkbox"/> a member of the board of directors of any municipal entity            |   |
| <input type="checkbox"/> an official of any municipality or municipal entity                   |   |

**If any of the above boxes are marked, disclose the following:**

Name of sole proprietor, partner, director, manager, principal shareholder or stakeholder	Name of institution, public office, board or organ of state and position held	Status of service (tick appropriate column)	
		current	Within last 12 months

\*insert separate page if necessary

**Section 7: Record of spouses, children and parents in the service of the state**

Indicate by marking the relevant boxes with a cross, if any spouse, child or parent of a sole proprietor, partner in a partnership or director, manager, principal shareholder or stakeholder in a company or close corporation is currently or has been within the last 12 months been in the service of any of the following:

- |  |   |
|--|---|
| <input type="checkbox"/> a member of any municipal council                                     | <input type="checkbox"/> an employee of any provincial department, national or provincial public entity or constitutional institution within the meaning of the Public Finance Management Act, 1999 (Act 1 of 1999) |
| <input type="checkbox"/> a member of any provincial legislature                                | <input type="checkbox"/> a member of an accounting authority of any national or provincial public entity  |
| <input type="checkbox"/> a member of the National Assembly or the National Council of Province | <input type="checkbox"/> an employee of Parliament or a provincial legislature  |
| <input type="checkbox"/> a member of the board of directors of any municipal entity            |   |
| <input type="checkbox"/> an official of any municipality or municipal entity                   |   |

Name of spouse, child or parent	Name of institution, public office, board or organ of state and position held	Status of service (tick appropriate column)	
		current	Within last 12 months

\*insert separate page if necessary

The undersigned, who warrants that he/she is duly authorised to do so on behalf of the enterprise:

- i) authorizes the Employer to obtain a tax clearance certificate from the South African Revenue Services that my / our tax matters are in order;
- ii) confirms that the neither the name of the enterprise or the name of any partner, manager, director or other person, who wholly or partly exercises, or may exercise, control over the enterprise appears on the Register of Tender Defaulters established in terms of the Prevention and Combating of Corrupt Activities Act of 2004;
- (a) iii) confirms that no partner, member, director or other person, who wholly or partly exercises, or may exercise, control over the enterprise appears, has within the last five years been convicted of fraud or corruption;
- iv) confirms that I / we are not associated, linked or involved with any other tendering entities submitting tender offers and have no other relationship with any of the tenderers or those responsible for compiling the scope of work that could cause or be interpreted as a conflict of interest;
- iv) confirms that the contents of this questionnaire are within my personal knowledge and are to the best of my belief both true and correct;

NAME: .....

POSITION: .....

SIGNATURE: .....

DATE: .....

*(of person authorised to sign on behalf of the Tenderer)*

## **THE CONTRACT**

C1: AGREEMENTS AND CONTRACT DATA

C2: PRICING DATA

C3: SCOPE OF WORK

C4: SITE INFORMATION



## TABLE OF CONTENTS

	<b>PAGE NO.</b>
C1: AGREEMENTS AND CONTRACT DATA.....	C3
C1.1: FORM OF OFFER AND ACCEPTANCE.....	C3
C1.2: CONTRACT DATA.....	C9
C1.3: PERFORMANCE GUARANTEE.....	C13
C1.4: DISCLOSURE STATEMENT.....	C16
C1.5: ADJUDICATION BOARD MEMBER AGREEMENT.....	C17
C1.6: RETENTION MONEY GUARANTEE (PRO FORMA).....	C19
C1.7: AGREEMENT IN TERMS OF SECTION 37(2) OF THE OCCUPATIONAL HEALTH AND SAFETY ACT No 85 OF 1993.....	C21

## C1: AGREEMENTS AND CONTRACT DATA

### C1.1: FORM OF OFFER AND ACCEPTANCE

#### A: Offer

The Employer, identified in the Acceptance signature block, has solicited offers to enter into a contract in respect of the following works:

.....

The Tenderer, identified in the Offer signature block below, has examined the documents listed in the Tender Data and addenda thereto as listed in the Tender Schedules, and by submitting this Offer has accepted the Conditions of Tender.

By the representative of the Tenderer, deemed to be du

I authorised, signing this part of this Form of Offer and Acceptance, the Tenderer offers to perform all of the obligations and liabilities of the Contractor under the Contract including compliance with all its terms and conditions according to their true intent and meaning for an amount to be determined in accordance with the Conditions of Contract identified in the Contract Data.

#### THE OFFERED TOTAL OF THE PRICES INCLUSIVE OF VALUE ADDED TAX IS

.....

.....Rand (in words); R ..... (in figures).

This Offer may be accepted by the Employer by signing the Acceptance part of this Form of Offer and Acceptance and returning one copy of this document to the Tenderer before the end of the period of validity stated in the Tender Data, whereupon the Tenderer becomes the party named as the Contractor in the Conditions of Contract identified in the Contract Data.

#### For the Tenderer:

**Signature:** .....

**Name:** .....

**Capacity:** .....

#### Name and address of organisation:

.....  
.....  
.....

**Signature and name of witness:**

**Signature:** .....

**Name:** .....

**Date:** .....

**B: Acceptance**

By signing this part of this Form of Offer and Acceptance, the Employer identified below accepts the Tenderer's Offer. In consideration thereof, the Employer shall pay the Contractor the amount due in accordance with the Conditions of Contract identified in the Contract Data. Acceptance of the Tenderer's Offer shall form an agreement between the Employer and the Tenderer upon the terms and conditions contained in this Agreement and in the Contract that is the subject of this Agreement.

The terms of the contract, are contained in

Part C1 Agreements and Contract Data, (which includes this Agreement)

Part C2 Pricing data

Part C3 Scope of work

Part C4 Site information

and drawings and documents or parts thereof, which may be incorporated by reference into Parts C1 to C4 above.

Deviations from and amendments to the documents listed in the Tender Data and any addenda thereto listed in the Tender Schedules as well as any changes to the terms of the Offer agreed by the Tenderer and the Employer during this process of offer and acceptance, are contained in the Schedule of Deviations attached to and forming part of this Agreement. No amendments to or deviations from said documents are valid unless contained in this Schedule, which must be duly signed by the authorised representative(s) of both parties.

The Tenderer shall within two weeks after receiving a completed copy of this Agreement, including the Schedule of Deviations (if any), contact the Employer's agent (whose details are given in the Contract Data) to arrange the delivery of any bonds, guarantees, proof of insurance and any other documentation to be provided in terms of the Conditions of Contract identified in the Contract Data at, or just after, the date this Agreement comes into effect. Failure to fulfil any of these obligations in accordance with those terms shall constitute a repudiation of this Agreement.

Notwithstanding anything contained herein, this Agreement comes into effect on the date when the Tenderer receives one fully completed original copy of this document, including the Schedule of Deviations (if any). Unless the Tenderer (now Contractor) within five days of the date of such receipt notifies the Employer in writing of any reason why he cannot accept the contents of this Agreement, this Agreement shall constitute a binding contract between the parties.

**For the Employer:**

**Signature:** .....

**Name:** .....

**Capacity:** .....

**Name and address of organisation:**

.....  
.....  
.....

**Signature and name of witness:**

**Signature:** .....

**Name:** .....

**Date:** .....

**C: Schedule of Deviations**

Notes:

1. The extent of deviations from the tender documents issued by the Employer prior to the tender closing date is limited to those permitted in terms of the Conditions of Tender.
2. A Tenderer's covering letter shall not be included in the final contract document. Should any matter in such letter, which constitutes a deviation as aforesaid become the subject of agreements reached during the process of offer and acceptance, the outcome of such agreement shall be recorded here.
3. Any other matter arising from the process of offer and acceptance either as a confirmation, clarification or change to the tender documents and which it is agreed by the Parties becomes an obligation of the contract shall also be recorded here.
4. Any change or addition to the tender documents arising from the above agreements and recorded here, shall also be incorporated into the final draft of the Contract.

**Subject** .....

**Details** .....

**Subject** .....

**Details** .....

By the duly authorised representatives signing this Schedule of Deviations, the Employer and the Tenderer agree to and accept the foregoing Schedule of Deviations as the only deviations from and amendments to the documents listed in the Tender Data and addenda thereto as listed in the Tender Schedules, as well as any confirmation, clarification or change to the terms of the offer agreed by the Tenderer and the Employer during this process of offer and acceptance.

It is expressly agreed that no other matter whether in writing, oral communication or implied during the period between the issue of the tender documents and the receipt by the Tenderer of a completed signed copy of this Agreement shall have any meaning or effect in the contract between the parties arising from this Agreement.

**For the Tenderer:**

**For the Employer:**

..... **Signature** .....

..... **Name** .....

..... **Capacity** .....

**Name and address of organisation:**

**Name and address of organisation:**

.....

.....

.....

.....

.....

.....

..... **Witness signature** .....

..... **Witness name** .....

..... **Date** .....

**D: CONFIRMATION OF RECEIPT**

The Tenderer, (now Contractor), identified in the Offer part of this Agreement hereby confirms receipt from the Employer, identified in the Acceptance part of this Agreement, of one fully completed original copy of this Agreement, including the Schedule of Deviations (if any) today:

the .....(day)

of.....(month)

20 ..... (year)

at.....(place)

**For the Contractor:**

**Signature:** .....

**Name:** .....

**Capacity:** .....

**Signature and name of witness:**

**Signature:** .....

**Name:** .....

## **C1.2: CONTRACT DATA**

### **C1.2.1: GENERAL CONDITIONS OF CONTRACT**

The General Conditions of Contract for Construction Works (3rd Edition 2015) published by the South African Institution of Civil Engineering, is applicable to this Contract and is obtainable from [www.saice.org.za](http://www.saice.org.za).

Copies of these conditions of contract may be obtained from the South African Institution of Civil Engineering (Tel 011- 805 5947, Fax: 011 – 805 5971).

The Contract Data referred to in the General Conditions of Contract follow, with the Data to be completed Employer furnished. The Tenderer is to provide his details in the spaces provided.



**C1.2.2: CONTRACT DATA PROVIDED BY EMPLOYER**

**CONTRACT No.: PWBS-B035/22/23**

**CONSTRUCTION OF CREIGHTON TOWN UPGARDE PHASE 2**

	<b>Clause (GCC 2015)</b>	
Defects Liability Period	1.1.1.13	Six (6) months
Name of Employer	1.1.1.15	DR NKOSAZANA DLAMINI ZUMA MUNICIPALITY
The Employer's address for receipt of communications is	1.2.1.2	Main Street CREIGHTON 3263 Email address: Tel: +27 39 833 1038 Fax: +27 39 833 1179
Time for Achieving Practical Completion	1.1.1.14	Sixteen (16) weeks
The name of the Employer's Agent is	1.1.1.16	FMA ENGINEERS (PTY) LTD
The Employer's Agent address for receipt of communications is	1.2.1.2	18 York Road GILLITTS 3610 Email: admin@fmaengineers.co.za Tel: +27 31 764 2763 Fax: +27 86 542 4084
Pricing Strategy	1.1.1.26	Re-measurement Contract
Documentation Required Before Commencement of Construction Works	5.3.1	Health and Safety File (Refer to Clause 4.3) Initial Programme (Refer to Clause 5.6) Security (Refer to Clause 6.2) Insurance (Refer to Clause 8.6)
Time to Submit the Documentation Before Commencement with the Works	5.3.2	28 days after commencement date
Non-working Days	5.1.1 & 5.8.1	Sundays
Special Non-working days	5.1.1 & 5.8.1	1. Usually the public holidays and voting days if applicable. 2. year -end break commencing and ending on dates as specified by SAFCEC. The normal working hours are: Monday to Friday 07h00 to 17h00 Saturday 07h00 to 15h00
Penalty for Failing to Complete the Works	5.13.1	R5, 000 per calendar day

	<b>Clause (GCC 2015)</b>	
Removal of plant from site without engineers written consent		<b>R 2 000 per calendar day.</b>
Late payment of local labour by 30 days from date of payment		<b>R 2 000 per calendar day</b>
Requirements to achieve Practical Completion	5.14.1	24 weeks
The Latent Defect Period	5.16.3	5 years
The Percentage Advance on Materials not yet Built into the Permanent Works	6.10.1.5	80% (subject to provision of Indemnity for Materials on Site)
Limit of Retention Money	6.10.3	10% of Contract Sum
Value of Plant and Material Supplied by Employer to be included in the insurance sum	8.6.1.1.2	Nil
Amount to cover professional fees for repairing damage and loss	8.6.1.1.3	14% of required repair work
Limit of Indemnity for Liability Insurance	8.6.1.3	R5, 000, 000.00 for each claim
Dispute Resolution	10.5.1	Standing Adjudication Board
Number of Adjudication Board Members to be Appointed	10.5.3	One
Dispute Determination	10.7.1	Dispute Determination shall be by Arbitration with the arbitrator chose by the sitting chairperson of the Association of Arbitrators Southern Africa NPC

**PART 2: DATA PROVIDED BY THE CONTRACTOR**

	<b>Clause</b>	
Name of Contractor	1.1.1.9	
Address of Contractor (Physical and Postal)  Tel: Fax: Email:	1.2.1.2	..... ..... ..... ..... .....
Security to be Provided by Contractor	6.2.1	Refer to Table Below
<b>Type of Security</b>		<b>Contractor's Choice (Indicate "YES" or "NO")</b>
<i>Is Value Added Tax included in the Contract Sum and value of Works for calculating percentages?</i>		
Cash deposit of .....% of the Contract Sum		
Performance Guarantee of .....% of the Contract Sum		
Retention of .....% of the value of Works		
Cash Deposit of .....% of the Contract Sum plus Retention of .....% of the value of Works		
Performance Guarantee of .....% of the Contract Sum plus Retention of .....% of the value of Works		
<p>Note: In the 'Standard for Uniformity in Construction Procurement' in Section 4.4.4.4 it is stated that: "Retention monies that are held shall not exceed 10% of any amount due to a contractor. Where guarantees of an insurance company or bank that are provided are equal to or greater than 10% of the contract price, the total amount of retention monies held shall not exceed 5% of the contract price."</p>		

**[NOTE: Delete inapplicable]**

NAME: ..... POSITION: .....

SIGNATURE: ..... DATE: .....

*(of person authorised to sign on behalf of the Tenderer)*

### C1.3: PERFORMANCE GUARANTEE

#### General Conditions of Contract for Construction Works, Third Edition (2015)

#### PRO FORMA PERFORMANCE GUARANTEE

For use with the General Conditions of Contract for Construction Works, Third Edition (2015).

#### GUARANTOR DETAILS AND DEFINITIONS

“Guarantor” means: .....

Physical address: .....

“Employer” means: .....

“Contractor” means: .....

“Employer's Agent” means:  
.....

“Works” means: .....

“Site” means: .....

“Contract” means: The Agreement made in terms of the Form of Offer and Acceptance and such amendments or additions to the Contract as may be agreed in writing between the parties.

“Contract Sum” means: The accepted amount inclusive of tax of R .....

Amount in words: .....

“Guaranteed Sum” means: The maximum aggregate amount of R .....

Amount in words: .....

Type of Performance Guarantee ..... (*Insert Variable or Fixed*)

“Expiry Date” means ..... (*Give date*) or any other later date set by the Contractor and/or Employer provided such instruction is received prior to the Expiry Date as indicated here.

#### CONTRACT DETAILS

Employer's Agent issues: Interim Payment Certificates, Final Payment Certificate and the Certificate of Completion of the Works as defined in the Contract.

#### 1. VARIABLE PERFORMANCE GUARANTEE

1.1 Where a Variable Performance Guarantee has been selected, the Guarantor's liability shall be limited during the following periods to diminishing amounts of the Guaranteed Sum as follows:

1.1.1 From and including the date of signing the Performance Guarantee up to and including the date of the interim payment certificate certifying, for the first time, more than 50% of the Contract Sum:

R.....

(Amount in words ..... )

1.1.2 From the day following the date of the said interim payment certificate up to and including the Expiry Date, or the date of issue by the Employer's Agent of the Certificate of Completion of the Works, whichever occurs first:

R.....

(Amount in words ..... )

- 1.2 The Employer's Agent and/or the Employer shall advise the Guarantor in writing of the date on which the interim payment certificate certifying, for the first time, more than 50% of the Contract Sum, has been issued and the date on which the Certificate of Completion of the Works has been issued.

## **2. FIXED PERFORMANCE GUARANTEE**

- 2.1 Where a Fixed Performance Guarantee has been selected, the Guarantor's liability shall be limited to the amount of the Guaranteed Sum.
- 2.2 The Guarantor's period of liability shall be from and including the date on which the Performance Guarantee is signed, up to and including the Expiry Date, or the date of issue by the Employer's Agent of the Certificate of Completion of the Works, or the date of payment in full of the Guaranteed Sum, whichever occurs first.
- 2.3 The Employer's Agent and/or the Employer shall advise the Guarantor in writing of the date on which the Certificate of Completion of the Works has been issued.

## **3. CONDITIONS APPLICABLE TO VARIABLE AND FIXED PERFORMANCE GUARANTEES**

- 3.1 The Guarantor hereby acknowledges that:
- 3.1.1 Any reference in this Performance Guarantee to the Contract is made for the purpose of convenience and shall not be construed as any intention whatsoever to create an accessory obligation or any intention whatsoever to create a surety ship.
- 3.1.2 Its obligation under this Performance Guarantee is restricted to the payment of money.
- 3.2 Subject to the Guarantor's maximum liability referred to in 1.1 or 2.1, the Guarantor hereby undertakes to pay the Employer the sum certified upon receipt of the documents identified in 3.2.1 to 3.2.3:
- 3.2.1 A copy of a first written demand issued by the Employer to the Contractor stating that payment of a sum certified by the Employer's Agent in an Interim or Final Payment Certificate has not been made in terms of the Contract and failing such payment within seven (7) calendar days, the Employer intends to call upon the Guarantor to make payment in terms of 3.2.2;
- 3.2.2 A first written demand issued by the Employer to the Guarantor at the Guarantor's physical address with a copy to the Contractor stating that a period of seven (7) days has elapsed since the first written demand in terms of 3.2.1 and the sum certified has still not been paid;
- 3.2.3 A copy of the aforesaid payment certificate which entitles the Employer to receive payment in terms of the Contract of the sum certified in 3.2.
- 3.3 Subject to the Guarantor's maximum liability referred to in 1.1 or 2.1, the Guarantor undertakes to pay to the Employer the Guaranteed Sum or the full outstanding balance upon receipt of a first written demand from the Employer to the Guarantor at the Guarantor's physical address calling up this Performance Guarantee, such demand stating that:
- 3.3.1 the Contract has been terminated due to the Contractor's default and that this Performance Guarantee is called up in terms of 3.3; or
- 3.3.2 a provisional or final sequestration or liquidation court order has been granted against the Contractor and that the Performance Guarantee is called up in terms of 3.3; and
- 3.3.3 the aforesaid written demand is accompanied by a copy of the notice of termination and/or the provisional/final sequestration and/or the provisional liquidation court order.
- 3.4 It is recorded that the aggregate amount of payments required to be made by the Guarantor in terms of 3.2 and 3.3 shall not exceed the Guarantor's maximum liability in terms of 1.1 or 2.1.

- 3.5 Where the Guarantor has made payment in terms of 3.3, the Employer shall upon the date of issue of the Final Payment Certificate submit an expense account to the Guarantor showing how all monies received in terms of this Performance Guarantee have been expended and shall refund to the Guarantor any resulting surplus. All monies refunded to the Guarantor in terms of this Performance Guarantee shall bear interest at the prime overdraft rate of the Employer's bank compounded monthly and calculated from the date payment was made by the Guarantor to the Employer until the date of refund.
- 3.6 Payment by the Guarantor in terms of 3.2 or 3.3 shall be made within seven (7) calendar days upon receipt of the first written demand to the Guarantor.
- 3.7 Payment by the Guarantor in terms of 3.3 will only be made against the return of the original Performance Guarantee by the Employer.
- 3.8 The Employer shall have the absolute right to arrange his affairs with the Contractor in any manner which the Employer may consider fit and the Guarantor shall not have the right to claim his release from this Performance Guarantee on account of any conduct alleged to be prejudicial to the Guarantor.
- 3.9 The Guarantor chooses the physical address as stated above for the service of all notices for all purposes in connection herewith.
- 3.10 This Performance Guarantee is neither negotiable nor transferable and shall expire in terms of 1.1.2 or 2.2, where after no claims will be considered by the Guarantor. The original of this Guarantee shall be returned to the Guarantor after it has expired.
- 3.11 This Performance Guarantee, with the required demand notices in terms of 3.2 or 3.3, shall be regarded as a liquid document for the purposes of obtaining a court order.
- 3.12 Where this Performance Guarantee is issued in the Republic of South Africa the Guarantor hereby consents in terms of Section 45 of the Magistrates' Courts Act No 32 of 1944, as amended, to the jurisdiction of the Magistrate's Court of any district having jurisdiction in terms of Section 28 of the said Act, notwithstanding that the amount of the claim may exceed the jurisdiction of the Magistrate's Court.

**Signed at** .....

**Date** .....

**Guarantor's signatory (1)** .....

**Capacity** .....

**Guarantor's signatory (2)** .....

**Capacity** .....

**Witness signatory (1)** .....

**Witness signatory (2)** .....

## C1.4: DISCLOSURE STATEMENT

### General Conditions of Contract for Construction Works, Third Edition (2015)

#### PRO FORMA

*Please note that words in italics within brackets are items which should be stated.*

(Date): .....

Contract: .....

Contractor:

Employer: DR NKOSAZANA DLAMINI ZUMA LOCAL MUNICIPALITY

Employer's Agent: FMA ENGINEERS (PTY) LTD

Dear Sirs

I am willing and available to serve as (*ad-hoc/standing*) Adjudication Board Member in the above-mentioned Contract.

In accordance with the General Conditions of Contract for Construction Works' Adjudication Board Rules relating to disclosure statements by selected or nominated persons to the adjudication, I hereby state that:

- I shall act with complete impartiality and know of nothing at this time, which could affect my impartiality.
- I have had no previous involvement with this project.
- I do not have any financial interest in this project.
- I am not currently employed by the Contractor, Employer or Employer's Agent.
- I do not have any financial connections with the Contractor, Employer or Employer's Agent.
- I do not have or have not had a personal relationship with any authoritative member of the Contractor, Employer or the Employer's Agent which could affect my impartiality.
- I undertake to immediately disclose to the parties any changes in the above position which could affect my impartiality or be perceived to affect same.

Should there be any deviation from the foregoing statements, details shall be given.

I further declare that I am experienced in the work which is carried out under the Contract and in interpreting contract documentation.

**Name in full:** .....

**Signature:** .....

## C1.5: ADJUDICATION BOARD MEMBER AGREEMENT

### General Conditions of Contract for Construction Works, Third Edition (2015)

#### PRO FORMA

*Please note that words in italics within brackets are items which should be stated.*

This Agreement is entered into between:

Adjudication Board Member:

Name .....

Physical address .....

Postal address .....

E-mail address .....

Fax number .....

Telephone number .....

Contractor:

Name .....

Physical address .....

Postal address .....

E-mail address .....

Fax number .....

Telephone number .....

The Contractor and the Employer will hereinafter be collectively referred to as the Parties.

The Parties entered into a Contract for *CONSTRUCTION OF CREIGHTON TOWN UPGRADE PHASE 2* which provides that a dispute under or in connection with the General Conditions of Contract for Construction Works, Third Edition (2015) must be referred to (*ad-hoc adjudication/standing adjudication*).

The undersigned natural person has been appointed to serve as Adjudication Board Member and together with the undersigned Parties agree as follows:

05

1. The Adjudication Board Member accepts to perform his duties in accordance with the terms of the Contract, the General Conditions of Contract for Construction Works' Adjudication Board Rules and this Agreement.
2. The Adjudicator undertakes to remain independent and impartial of the Contractor, Employer and Employer's Agent for the duration of the Adjudication Board proceedings.
3. The Adjudication Board Member agrees to serve for the duration of the Adjudication Board proceedings.



4. The Parties may at any time, without cause and with immediate effect, jointly terminate this Agreement.
5. Unless the Parties agree, the Adjudication Board Member shall not act as arbitrator or representative of either Party in any subsequent proceedings between the Parties under the Contract. No Party may call the Adjudication Board Member as a witness in any such subsequent proceedings.
6. The standing Adjudication Board's duties shall end upon the Adjudication Board Member(s) receiving notice from the Parties of their joint decision to disband the Adjudication Board.
7. The Adjudication Board Member shall be paid in respect of time spent upon or in connection with the adjudication including time spent traveling:
  - 7.1 A monthly retainer of.....for ..... of months, and/or
  - 7.2 A daily fee of ..... based on a.....hour day, and/or
  - 7.3 An hourly fee of.....and/or
  - 7.4 A non-recurrent appointment fee of..... which shall be accounted for in the final sums payable.
8. The Adjudication Board Member's expenses incurred in adjudication work shall be reimbursed at cost.

On submission of an invoice for fees and expenses to the Parties, the Parties shall pay the full amount within 28 days of receipt of the invoice. Late payment of such invoice shall attract interest at prime plus 3% points compounded monthly at the prime rate charged by the Adjudication Board Member's bank.

This Agreement is entered into by:

**Contractor's signature:** .....

**Contractor's name:** .....

**Place:** .....

**Date:** .....

**Employer's signature:** .....

**Employer's name:** .....

**Place:** .....

**Date:** .....

**Adjudication Board Member's signature:** .....

**Adjudication Board Member's name:** .....

**Place:** .....

**Date:** .....

**C1.6: RETENTION MONEY GUARANTEE (PRO FORMA)**

ISSUED TO..... hereinafter called "the Employer")

ON BEHALF OF ..... [insert name of contractor]  
(hereinafter called "the Contractor")

in connection with CONTRACT No.: PWBS-B035/22/23 CONSTRUCTION OF CREIGHTON TOWN  
UPGARDE (PHASE 2) (hereinafter called "the Contract").

WHEREAS the Employer and the Contractor have agreed that the Contractor may provide a guarantee in lieu  
of the whole or a portion of the retention moneys provided for under the Contract;

NOW THEREFORE we, the undersigned, undertake, in accordance with the following provisions, to pay to the  
Employer such amounts as the Employer may, from time to time, demand from us.

1 Each demand by the Employer shall be in writing, signed by the Employer and delivered to us at

[INSERT GUARANTOR'S FULL STREET  
ADDRESS].....

..... or such other address in  
[INSERT NAME OF COUNTRY].....as we shall in writing notify to the Employer  
and shall be accompanied by a certificate complying with Clause 2, signed by the Engineer in office as such  
in terms of the Contract.

2 The Engineer's certificates referred to in Clause 1 shall certify that:

- (a) he is the Engineer in office as such in terms of the Contract,
- (b) the Contractor is in breach of his obligations under the Contract, and
- (c) the amount demanded, which amount the certificate shall specify, does not exceed
  - (i) the amount of retention moneys which, but for this guarantee, would have been retained by the Employer in terms of the Contract at the date of the certificate, less the aggregate of the amounts of retention money retained by the Employer and the amounts previously paid by us to the Employer in terms hereof,
  - (ii) a genuine estimate of the cost to the Employer of having the breach referred to in paragraph (b) remedied less the aggregate of any amounts withheld by the Employer from payments due to the Contractor in terms of the Contract by reason of the breach referred to, and any amount of retention money actually held by the Employer save to the extent that the same had been deducted from any previous demand in terms hereof;

- 3 We shall within fourteen (14) days after our receipt of a demand complying with the provisions in Clauses 1 and 2 make payment to the Employer of the amount demanded at the employer's address as listed in the contract data or at such other address in the Republic of South Africa as the Employer shall in writing notify to us.
- 4 Subject to compliance with the provisions hereof, our liability to make the payments herein referred to shall be unconditional and shall not be affected or diminished by any disputes, claims or counterclaims between the Employer and the Contractor.
- 5 Our aggregate liability under this guarantee is limited to .....  
  
..... (R )
- 6 This guarantee shall expire on the date on which the last of the retention moneys, which but for this guarantee would have been retained by the Employer, becomes payable to the Contractor.
- 7 This guarantee is not transferable and must be produced for endorsement if any part payment is made and must be returned to us against final payment of our aggregate liability or on the date of the expiry of the guarantee in terms of Clause 6, whichever is the earlier.

Signed in the presence of the subscribing witnesses:

At for and on behalf of .....

on this the ..... day of ..... 20.....

SIGNATURE : .....

CAPACITY : .....

ADDRESS : .....

: .....

: .....

AS WITNESSES: 1 .....

2 .....

**C1.7: AGREEMENT IN TERMS OF SECTION 37(2) OF THE OCCUPATIONAL HEALTH AND SAFETY ACT No 85 OF 1993**

THIS AGREEMENT is made between DR NKOSAZANA DLAMINI ZUMA LOCAL MUNICIPALITY (hereinafter called the

EMPLOYER) of the one part, herein represented by: .....

.....  
in his capacity as: .....

AND: .....

(hereinafter called the CONTRACTOR) of the other part, herein represented by .....

.....  
in his capacity as: .....

duly authorized to sign on behalf of the Contractor.

**WHEREAS** the CONTRACTOR is the Mandatory of the EMPLOYER in consequence of an agreement between the CONTRACTOR and the EMPLOYER in respect of

CONTRACT No.....(CONTRACT TITLE)

..... for the  
construction, completion and maintenance of the works;

AND WHEREAS the EMPLOYER and the CONTRACTOR have agreed to enter into an agreement in terms of the provisions of Section 37(2) of the Occupational Health and Safety Act No 85 of 1993, as amended by OHS Act Amendment Act No 181/1993 (hereinafter referred to as the ACT);

**NOW THEREFORE** the parties agree as follows:

1. The CONTRACTOR undertakes to acquaint the appropriate officials and employees of the CONTRACTOR with all relevant provisions of the ACT and the regulations promulgated in terms thereof.
2. The CONTRACTOR undertakes to fully comply with all relevant duties, obligations and prohibitions imposed in terms of the ACT and Regulations: Provided that should the EMPLOYER have prescribed certain arrangements and procedures that same shall be observed and adhered to by the CONTRACTOR, his officials and employees. The CONTRACTOR shall bear the onus of acquainting himself/herself/itself with such arrangements and procedures.
3. The CONTRACTOR hereby accepts sole liability for such due compliance with the relevant duties, obligations, prohibitions, arrangements and procedures, if any, imposed by the ACT and Regulations, and the CONTRACTOR expressly absolves the EMPLOYER and the Employer's CONSULTING ENGINEERS from being obliged to comply with any of the aforesaid duties, obligations, prohibitions, arrangements and procedures in respect of the work included in the contract.
4. The CONTRACTOR agrees that any duly authorized officials of the EMPLOYER shall be entitled, although not obliged, to take such steps as may be necessary to ensure that the CONTRACTOR has complied with his undertakings as more fully set out in paragraphs 1 and 2 above, which steps may include, but shall not be limited to, the right to inspect any appropriate site or premises occupied by the CONTRACTOR, or to take such steps it may deem necessary to remedy the default of the CONTRACTOR at the cost of the CONTRACTOR.
5. The CONTRACTOR shall be obliged to report forthwith to the EMPLOYER any investigation, complaint or criminal charge which may arise as a consequence of the provisions of the ACT and Regulations,

pursuant to work performed in terms of this agreement, and shall, on written demand, provide full details in writing of such investigation, complaint or criminal charge.

Thus signed at..... for and on behalf of the **CONTRACTOR**

on this the ..... day of ..... 20.....

SIGNATURE:.....

NAME AND SURNAME: .....

CAPACITY: .....

WITNESSES: 1. ....

2. ....

Thus signed at..... for and on behalf of the **EMPLOYER**

on this the ..... day of ..... 20.....

SIGNATURE:.....

NAME AND SURNAME: .....

CAPACITY: .....

WITNESSES: 1. ....

2. ....

## TABLE OF CONTENTS

	<b>PAGE NO.</b>
C2.1 PRICING INSTRUCTIONS .....	PD. 2
C2.2 SCHEDULE OF QUANTITIES.....	PD. 5

## C2.1 PRICING INSTRUCTIONS

- 1 The Conditions of Contract, the Contract Data, the Specifications (including the Project Specifications) and the Drawings shall be read in conjunction with the Bill of Quantities.
- 2 The Bill comprises items covering the Contractor's profit and costs of general liabilities and of the construction of Temporary and Permanent Works.

Although the Tenderer is at liberty to insert a rate of his own choosing for each item in the Bill, he should note the fact that the Contractor is entitled, under various circumstances, to payment for additional work carried out and that the Engineer is obliged to base his assessment of the rates to be paid for such additional work on the rates the Contractor inserted in the Bill. Clause 8 of each Standardized Specification, and the measurement and payment clause of each Particular Specification, read together with the relevant clauses of the Project Specifications, all set out which ancillary or associated activities are included in the rates for the specified operations

- 3 Descriptions in the Bill of Quantities are abbreviated and may differ from those in the Standardized and Project Specifications. No consideration will be given to any claim by the Contractor submitted on such a basis. The Bill has been drawn up generally in accordance with the latest issue of Civil Engineering Quantities. Should any requirement of the measurement and payment clause of the appropriate Standardized or Project Specification(s) be contrary to the terms of the Bill or, when relevant, to the Civil Engineering Quantities, the requirement of the appropriate Standardized, Project, or Particular Specification as the case may be, shall prevail
- 4 Unless stated to the contrary, items are measured net in accordance with the Drawings without any allowance having been made for waste.
- 5 The amounts and rates to be inserted in the Bill of Quantities shall be the full inclusive amounts to the Employer for the work described under the several items. Such amounts shall cover all the costs and expenses that may be required in and for the construction of the work described, and shall cover the costs of all general risks, profits, taxes (but excluding value-added tax), liabilities and obligations set forth or implied in the documents on which the Tender is based.
- 6 An amount or rate shall be entered against each item in the Bill of Quantities, whether or not quantities are stated. An item against which no amount or rate is entered will be considered to be covered by the other amounts or rates in the Bill.

The Tenderer shall also fill in a rate against the items where the words "rate only" appear in the amount column. Although no work is foreseen under these items and no quantities are consequently given in the quantity column, the tendered rates shall apply should work under these items actually be required.

Should the Tenderer group a number of items together and tender one sum for such group of items, the single tendered sum shall apply to that group of items and not to each individual item, or should he indicate against any item that full compensation for such item has been included in another item, the rate for the item included in another item shall be deemed to be nil.

The tendered rates, prices and sums shall, subject only to the provisions of the Conditions of Contract, remain valid irrespective of any change in the quantities during the execution of the Contract.

- 7 The quantities of work as measured and accepted and certified for payment in accordance with the Conditions of Contract, and not the quantities stated in the Bill of Quantities, will be used to determine payments to the Contractor. The validity of the Contract shall in no way be affected by differences between the quantities in the Bill of Quantities and the quantities certified for payment.

**Ordering of materials is not to be based on the Bill of Quantities, but only on information issued for construction purposes.**

8 For the purposes of this Bill of Quantities, the following words shall have the meanings hereby assigned to them:

- Unit : The unit of measurement for each item of work as defined in the Standardized, Project or Particular Specifications
- Quantity : The number of units of work for each item
- Rate : The payment per unit of work at which the Tenderer tenders to do the work
- Amount : The quantity of an item multiplied by the tendered rate of the (same) item
- Sum : An amount tendered for an item, the extent of which is described in the Bill of Quantities, the Specifications or elsewhere, but of which the quantity of work is not measured in units

9 The units of measurement indicated in the Bill of Quantities are metric units. The following abbreviations may appear in the Bill of Quantities:

- mm = millimetre
- m = metre
- km = kilometre
- km-pass = kilometre-pass
- m<sup>2</sup> = square metre
- m<sup>2</sup>-pass = square metre-pass
- ha = hectare
- m<sup>3</sup> = cubic metre
- m<sup>3</sup>-km = cubic metre-kilometre
- kW = kilowatt
- kN = kilonewton
- kg = kilogram
- t = ton (1 000 kg)
- % = per cent
- MN = meganewton
- MN-m = meganewton-metre
- PC Sum = Prime Cost Sum
- Prov Sum = Provisional Sum

10 Payment for the Labour-Intensive Component of the Works:

Those parts of the works to be constructed using labour-intensive methods are marked in the bill of quantities with the letters LI either in a separate column or as a prefix or suffix against every item so designated. The works, or parts of the works so designated are to be constructed using labour-intensive methods only. The use of plant to provide such works, other than plant specifically provided for in the scope of work, is a deviation from the contract. The items marked with the letters LI are not necessarily an exhaustive list of all the activities which must be done by hand and this clause does not over-ride any of the requirements in the generic labour-intensive specification in the Scope of Works.

Where minimum labour intensity is specified in the design, the contractor is expected to use their initiative to identify additional activities that can be done labour-intensively in order to comply with the set minimum labour intensity targets.

Payment for items which are designated to be constructed labour-intensively (either in this schedule or in the Scope of Works) will not be made unless they are constructed using labour-intensive methods. Any unauthorised use of plant to carry out work which was to be done labour-intensively will not be condoned and any works so constructed will not be certified for payment. Any non-payment for such works shall not relieve the Contractor in any way from his obligations either in contract or in delict



11. Linkage of Payment for Labour-Intensive Component of Works to Submission of Project Data

The Contractor's payment invoices shall be accompanied by labour information for the corresponding period in a format specified by the employer. If the contractor chooses to delay submitting payment invoices, labour returns shall still be submitted as per frequency and timeframes stipulated by the Employer. The contractor's invoices shall not be paid until all pending labour information has been submitted. The client may institute a penalty relating to outstanding labour information.

The following information shall be maintained on site and submitted in electronic/hard copy formats:

- Certified ID copies of all locally employed labour
- Signed Contracts between the employer and the EPWP Participants
- Attendance Registers for the EPWP Participants
- Proof of Payment of EPWP Employees
- Monthly Reporting Template as per EPWP requirements

## **C2.2 SCHEDULE OF QUANTITIES**





ITEM	LI	DESCRIPTION	UNIT	QTY	RATE	AMOUNT c	R
13.00		CONTRACTOR'S ESTABLISHMENT ON SITE AND GENERAL OBLIGATIONS					
B13.01		Contractor's general obligations					
		(a) Fixed obligations	L/sum	1,0			
		(b) Value-related obligations	L/sum	1,0			
		(c) Time-related obligations	Month	4,0			
B13.02		Health and Safety obligations					
		(a) Provision of Personal Protective Equipment (PPE) & Clothing for all the Contractor's staff, including sub-contractors as per EPWP guidelines	P.C Sum	1,0	5 000,00		R 5 000,00
		(b) Handling cost and profit in respect of item B13.02 (a)	%	5 000,00			
B 13.03		COVID-19					
		(a) Provision for compliance with COVID 19 Regulations (Government Gazette No. 43257, 29 APRIL 2020)	P.C Sum	1,00	5 000,00		R 5 000,00
		(b) Handling cost and profit in respect of item B13.02 (a)	%	5000,0			
B13.04		Supply, transport to site and erection of the contract signboard					
		(a) Contract sign boards	No	1,0			
		(b) Information boards	No	2,0			
		(c) Rocla Pre-cast Concrete Bus Shelters, size 1606 x 2400mm high	No	2,0			
		(d) Provision of Replacing missing Welcome sign letters	P.C Sum	1,0	10 000,00		R 10 000,00
TOTAL CARRIED FORWARD TO SUMMARY							

ITEM	LI	DESCRIPTION	UNIT	QTY	RATE	AMOUNT	R
						c	
<b>15.00</b>		<b>ACCOMMODATION OF TRAFFIC</b>					
15,01		Accommodating traffic and maintaining temporary deviations	km	0,5			
15,02		Earthworks for temporary deviations:					
		(a) Shaping of temporary deviations	km	R/O			R/O
		(b) Cut and borrow to fill	m <sup>3</sup>	R/O			R/O
		(c) Cut to spoil	m <sup>3</sup>	R/O			R/O
15,03	LIC	Temporary traffic-control facilities:					
		(a) Flagmen	man-day	145,0			
		(b) Portable STOP and GO-RY signs	No	6,0			
		(e) Road signs, R and TR series, (900mm diameter)	No	6,0			
		(f) Road signs, TW series, (900mm diameter)	No	8,0			
		(h) Delineators (DTG50J) (600mmx150mm):					
		(i) Single	No	8,0			
		(ii) Mounted back to back	No	8,0			
		(j) Traffic cones (600mm)	No	8,0			
B15.03		(n) Extra signs as ordered by the engineer					
		(i) Provision of other signs or facilities	P.C. Sum	1,0	2 500,00		R 2 500,00
		(ii) Contractors handling charge and profit on subsubitem B15.03(n)(i)	%	2500,0			
15,04		Relocation of traffic-control facilities	Lump Sum	1,0			
15,06		Watering of temporary deviations	kl	10,0			
15,07		Blading by road grader of:					
		(a) Temporary deviations	km-pass	0,5			
15,10		Accommodation of traffic where the road is constructed in halfwidths	km	0,2			
15,12		Temporary culverts:					
		(a) Provision and laying of temporary prefabricated culverts complete (state size, type and bedding)					
		600mm dia. Class 50D on a Class C bedding	m	R/O			R/O
		(c) Eventual removal of prefabricated culverts	m	R/O			R/O
B15.15		Penalties:					
		(a) (i) Fixed penalty for noncompliance of traffic safety requirements per occurrence	No	R/O	5 290,00		R/O
		(b) (ii) Time related penalty for B15.15 (a)(i) above	Day	R/O	5 000,00		R/O
		(c) (i) Fixed penalty for noncompliance with COVID-19 Occupational Health and Safety measures in workplaces COVID-19 (C19 OHS), 2020	No	R/O	11 500,00		R/O
		(d) (ii) Time related penalty for B15.15 (c)(i) above	Day	R/O	5 000,00		R/O
TOTAL CARRIED FORWARD TO SUMMARY							

ITEM	LI	DESCRIPTION	UNIT	QTY	RATE	AMOUNT c	R
18.00		DAYWORKS					
B18.01		Vehicles, plant and equipment					
		(a) Lowbed: Transport of plant to or from site	hr	1,0			
		(b) Motor grader					
		(i) Up to 100Kw and mass 12 tonne	hr	1,0			
		(c) Loader					
		(i) Rubber tyred up to 60 Kw and mass 12 tonne	hr	1,0			
		(d) Backhoe excavators					
		(i) Rubber tyred up to 60 Kw and mass 12 tonne	hr	1,0			
		(e) Self propelled compactors					
		(i) With static mass between 6 and 8 tonnes	hr	1,0			
		(f) Walk behind vibrating roller					
		(i) Static mass greater than 800 kg	hr	1,0			
		(g) Tamping platecompactor					
		(i) Static mass greater than 60 kg	hr	1,0			
		(h) Trucks					
		(i) Tipper up to 6 m <sup>3</sup> capacity	hr	1,0			
		(ii) Tipper more than 6 m <sup>3</sup> capacity	hr	1,0			
		(iii) Flatbed truck more than 7 tonne capacity	hr	1,0			
		(i) Water Truck					
		(i) Up to 7000 litres	hr	1,0			
		(ii) Up to 12000 litres	hr	1,0			
		(j) Compressor					
		(i) Up to 10 m3/min	hr	1,0			
		(k) Concrete Mixer					
		(i) Up to 0.3 m3 dry mix capacity	hr	1,0			
B18.02		Personnel					
		(a) Artisan (Member of Industrial Council)	hr	3,0			
		(b) Artisan (Non-member of Industrial Council)	hr	3,0			
		(c) Ganger	hr	6,0			
		(d) Labourer	hr	14,0			
B18.03		Materials					
		(a) Procurement of materials	Prov Sum	1,00	50 000,00		R 50 000,00
		Contractors handling costs, profit and all other charges in respect of subitem B18.03(a) (state % and extend as an amount)	%	50000,0			
TOTAL CARRIED FORWARD TO SUMMARY							

SECTION	DESCRIPTION		AMOUNT c R
	<b>ROADWORKS</b>		
1200	GENERAL REQUIREMENTS AND PROVISIONS		
1300	CONTRACTOR'S ESTABLISHMENT ON SITE AND GENERAL OBLIGATIONS		
1500	ACCOMMODATION OF TRAFFIC		
1800	DAYWORKS		
	<b>TOTAL CARRIED FORWARD TO COMPOSITE SUMMARY</b>		



Item	LI	Description	Unit	Quantity	Rate	Amount c R
16.00		OVERHAUL				
B16.02		Overhaul on material hauled in excess of a freehaul distance of 1.0 km	m3-km	500,0		
TOTAL CARRIED FORWARD TO SUMMARY						

Item	LI	Description	Unit	Quantity	Rate	Amount c	R
17.00		CLEARING AND GRUBBING					
B17.01	LIC	Clearing and grubbing	ha	0,05			
17.02	LIC	Removal and grubbing of large trees and tree stumps (a) Girth exceeding 1m up to and including 2m	No				R/O
17.03	LIC	Re-clearing of surfaces (on the written instructions of the Engineer only)	ha				R/O
17.04	LIC	Clearing and grubbing at inlets and outlets of hydraulic structures	m <sup>2</sup>	100,0			
17.05	LIC	Cleaning out of hydraulic structures: (a) Pipes with an internal diameter up to and including 750 mm	m <sup>3</sup>	5,0			
TOTAL CARRIED FORWARD TO SUMMARY							

Item	LI	Description	Unit	Quantity	Rate	Amount	R	
						c		
21.00		DRAINS						
21,01		Excavation for open drains						
		(a) Excavating soft material situated within the following depth ranges below the surface level:						
		(i) 0 m up to 1,5 m	m <sup>3</sup>	50				
		(ii) Exceeding 1,5 m and up to 3,0 m	m <sup>3</sup>	10,0				
		(b) Extra over sub-item 21.01(a) for excavation in hard material, irrespective of depth	m <sup>3</sup>	10,0				
21,02		Clearing and shaping existing open drains:						
	LIC	(a) In soft material	m <sup>3</sup>	10,0				
TOTAL CARRIED FORWARD TO SUMMARY								

Item	LI	Description	Unit	Quantity	Rate	Amount c	R
22.00		PREFABRICATED CULVERTS					
22.01		Excavation (a) Excavating soft material situated within the following depth ranges below the surface level: (1) 0 m up to 1.5 m (2) Exceeding 1,5 m and up to 3,0 m (b) Extra over subitem 22.01(a) for excavation in hard material, irrespective of depth	m <sup>3</sup> m <sup>3</sup> m <sup>3</sup>	150,0 5,0 5,0			
22.02		Backfilling: (a) Using the excavated material (b) Using imported selected material	m <sup>3</sup> m <sup>3</sup>	100,0 5,0			
B22.03		Concrete pipe culverts: (c) On class C bedding (2) 450mm dia. Type 75D (2) 600mm dia. Type 75D (2) 900mm dia. Type 75D	m m m	R/O 50,0 R/O			R/O R/O
22,13		Removing and Relaying existing pipes. (b) 450 mm Dia. (c) 600 mm Dia. (d) 900 mm Dia.	m m m	R/O 5,0 R/O			R/O R/O
22.17		Manholes, catchpits, precast inlet and outlet structures complete (a) Manholes (3) Brick manholes for drainage: constructed on all pipes up to 675 mm diameter (i) Up to 1,0 m deep (ii) 1,0 m to 1,5 m deep (b) Catchpits	No No	2,0 2,0			
	LIC	(1) Single splay inlet in concrete side drain as per drawing	No	1,0			
	LIC	(2) Double splay inlet in concrete side drain as per drawing	No	R/O			R/O
22.18		Brickwork (a) 115 mm thick (b) 230 mm thick	m <sup>2</sup> m <sup>2</sup>	10,0 15,0			
		Overhaul on excavated material carted to spoil, backfill material (but excluding Portland cement in the case of soil cement), existing structures demolished and removed to spoil, and removing and relaying, and removing and stacking existing prefabricated culverts, for haul in excess of the free-haul distance	m <sup>3</sup> .km	1525,0			
22.19		Accessories ( a ) Wall Cladding Tiles	m <sup>2</sup>	60,0			
22.20		( b ) 60mm interlocking paving blocks	m <sup>2</sup>	100,0			
TOTAL CARRIED FORWARD TO SUMMARY							

Item	LI	Description	Unit	Quantity	Rate	Amount c	R
23.00		CONCRETE KERBING, CONCRETE CHANNELLING, CHUTES AND DOWNPIPES, AND CONCRETE LININGS FOR OPEN DRAINS					
23.01		Concrete kerbing (a) Precast kerbing to SABS 927					
	LIC	(i) Figure 6 kerb	m	200,0			
		(b) Extra-over item 23.01 (a) for :					
	LIC	(i) Radius of 1 m to 4 m	m	5,0			
	LIC	(ii) Radius of 4 m to 20 m	m	5,0			
23.02		Concrete kerbing-channelling combination (a) Precast kerb to SABS 927 and cast in situ channel 300 mm concrete class 20/13)					
	LIC	(i) Figure 6 kerb	m	20,0			
23.05		Inlet, outlet, transition and similar structures (typical designs):					
	LIC	(a) Outlet structures for side drains.	No	6,0			
	LIC	(b) Transition structures for catchpits.	No	1,0			
23.07		Trimming of excavations for concrete-lined open drains and sidewalks					
	LIC	(a) In soft material	m <sup>2</sup>	600,0			
	LIC	(b) In hard material	m <sup>2</sup>	10,0			
23,08		Concrete lining for open drains					
		(a) Cast in situ concrete lining class 25/19 open drains					
	LIC	(1) Standard side drain as per drawing	m <sup>3</sup>	125,0			
		(b) Class U2 surface finish to cast in situ concrete for open drains					
	LIC	(1) Standard side drain as per drawing	m <sup>2</sup>	750,0			
23,09		Formwork to cast in situ concrete lining for open drains (Class F2 surface finish)					
	LIC	(c) To ends of slabs	m <sup>2</sup>	10,0			
	LIC	(d) To outside and/or inside edges of concrete lined drains and sidewalks	m <sup>2</sup>	50,0			
23.10		Sealed joints in concrete linings of open drains					
		(a) Polysulphide sealants	m	220,0			
23.12		Steel reinforcement					
	LIC	(c) Welded steel fabric Ref 193	m <sup>2</sup>	750,0			
23,16		Demolition and removal of existing kerbs and or channel, concrete lined drains (maximum size 300mm)	m <sup>3</sup>	100,0			
TOTAL CARRIED FORWARD TO SUMMARY							

Item	LI	Description	Unit	Quantity	Rate	Amount	R
						c	
33.00		MASS EARTHWORKS					
33.01 / B16.02		Cut, stockpile and borrow to fill, including free-haul up to 1.0km					
		(a) Material in compacted layer thickness of 150 mm and less:					
		(ii) Compacted to 93% of modified AASHTO	m <sup>3</sup>	20,0			
		(iii) Eight roller passes compaction	m <sup>3</sup>	25,0			
33.03		Extra over item 33.01 for excavating and breaking down material in:					
		(a) Intermediate excavation	m <sup>3</sup>	5,0			
		(b) Hard excavation	m <sup>3</sup>	5,0			
33.04 / B16.02		Cut to spoil, including free-haul up to 1.0 km. Material obtained from:					
		(a) Soft excavation	m <sup>3</sup>	120,0			
		(b) Hard Excavation	m <sup>3</sup>	10,0			
33.07 / B16.02		Removal of unsuitable material (including free-haul of 1.0 km):					
		(a) In layer thicknesses of 200 mm and less:					
		(1) Stable material	m <sup>3</sup>	5,0			
		(2) Unstable material	m <sup>3</sup>	5,0			
33.10		Roadbed preparation and the compaction of material					
		(b) Compacted to 93% of modified AASHTO	m <sup>3</sup>	80			
33.11		Three-roller-passes compaction:					
		(a) Vibratory roller	m <sup>2</sup>	500,0			
TOTAL CARRIED FORWARD TO SUMMARY							

Item	LI	Description	Unit	Quantity	Rate	Amount	R	
						c		
34.00 B34.01		PAVEMENT LAYERS OF GRAVEL MATERIAL Pavement layers constructed from gravel, including free haul up to 1,0 km (a) Gravel selected layer obtained from stockpile compacted to: (i) 93% of modified AASHTO density (150mm layer thickness) (d) Gravel subbase obtained from commercial sources (chemically stabilised material) compacted to: (i) 95% of modified AASHTO density (150mm layer thickness) (g) Gravel shoulders compacted to: (i) 93% of modified AASHTO density (specify compacted layer thickness)	  m <sup>3</sup>  m <sup>3</sup>  m <sup>3</sup>	  10  60  10				
TOTAL CARRIED FORWARD TO SUMMARY								

Item	LI	Description	Unit	Quantity	Rate	Amount c R
36.00 36,01		CRUSHED STONE BASE Crushed-stone base (c) Constructed from type G2 material obtained from commercial sources and compacted to 88% of apparent relative density, 150mm thick (1) 37mm nominal maximum size stone	m <sup>3</sup>	135,0		
TOTAL CARRIED FORWARD TO SUMMARY						



Item	LI	Description	Unit	Quantity	Rate	Amount c	R
41.00		PRIME COAT					
41.01		Prime coat: (d) MC-30 cut-back bitumen 0.8l/m2	m <sup>2</sup>	100,0			
41.02		Aggregate for blinding	m <sup>2</sup>	100,0			
41.03		Extra over item 41.01 for applying the prime coat in areas accessible only to hand held equipment	l	2,0			
TOTAL CARRIED FORWARD TO SUMMARY							

Item	LI	Description	Unit	Quantity	Rate	Amount c	R
4200		ASPHALT BASE AND SURFACING					
42,02		Asphalt surfacing					
		(a) Continuously graded (Medium graded)					
		(i) 30mm thick, A-P1 Bitumen	m <sup>2</sup>	100,0			
42,03		Rolled in chippings in surfacing					
		(a) 13 mm nominal size	t	2,00			
42.04		Tack coat of 30% stable-grade emulsion	m <sup>2</sup>	100,0			
B42.08		100 mm cores in asphalt paving	No	R/O			R/O
B42.23		Speed hump (80mm thickness using 60/40 pen bitumen)	m <sup>2</sup>	45,0			
TOTAL CARRIED FORWARD TO SUMMARY							

Item	LI	Description	Unit	Quantity	Rate	Amount c	R
51.00		PITCHING, STONWORK AND PROTECTION AGAINST EROSION					
51.01		Stone pitching:					
	LIC	(b) Grouted stone pitching	m <sup>2</sup>	40,0			
51.05		Concrete edge beams					
	LIC	(a) Class 25/19	m <sup>3</sup>	6,0			
TOTAL CARRIED FORWARD TO SUMMARY							

Item	LI	Description	Unit	Quantity	Rate	Amount c	R
52.00		GABIONS					
52.01		Foundation trench excavation and backfilling:					
	LIC	(b) In all other classes of materials	m <sup>3</sup>	R/O		R/O	
52.02	LIC	Surface preparation for bedding the gabions	m <sup>2</sup>	R/O		R/O	
52.03		Gabions:					
		(a) Galvanized gabion boxes					
		(3) 1,0 m wide by 1,0 m high					
	LIC	(ii) by 2,0 m long	m <sup>3</sup>	R/O		R/O	
		(c) Galvanized gabion mattresses					
		(1) 1,0 m diaphragm spacing, 6,0 m long by 2,0 m wide					
	LIC	(ii) by 0,3 m deep mesh	m <sup>3</sup>	R/O		R/O	
52.04		Filter fabric					
	LIC	(b) Grade C	m <sup>2</sup>	R/O		R/O	
TOTAL CARRIED FORWARD TO SUMMARY							

Item	LI	Description	Unit	Quantity	Rate	Amount	R
						c	
56.00		ROAD SIGNS					
56.01		Road sign boards with painted or coloured semi-matt background. Symbols, lettering and borders in semi-matt black or in Class 1 retro-reflective material, where the sign board is constructed from:					
		(c) Prepainted galvanised steel plate (chromadek or approved equivalent)					
	LIC	(i) Area not exceeding 2 m <sup>2</sup>	m <sup>2</sup>	25,0			
56.02		Extra over item 56.01 for using:					
		(a) Background of retro-reflective material of:					
	LIC	(i) Class I	m <sup>2</sup>	25,0			
56.03		Road sign supports (overhead road sign structures excluded):					
		(b) Timber					
	LIC	(2) 110-125 mm dia.	m	50,0			
56.05	LIC	Excavation and backfilling for road sign supports	m <sup>3</sup>	20,0			
56.06	LIC	Extra over item 56.05 for cement-treated soil backfill	m <sup>3</sup>	20,0			
TOTAL CARRIED FORWARD TO SUMMARY							

Item	LI	Description	Unit	Quantity	Rate	Amount c	R
57.00		ROAD MARKINGS					
57.02		Retro-reflective road marking paint:					
		(a) White lines (broken or unbroken)					
		(1) 100 mm wide	km	1,00			
		(2) 300 mm wide	km	1,0			
		(d) White lettering and symbols	m <sup>2</sup>	100,0			
57.06		Setting out and premarking the lines (Excluding traffic-island markings, lettering and symbols)	km	1,00			
TOTAL CARRIED FORWARD TO SUMMARY							

Item	LI	Description	Unit	Quantity	Rate	Amount c	R
58.00		LANDSCAPING AND PLANTING PLANTS					
58.01		Trimming					
	LIC	(a) Machine trimming	m <sup>2</sup>	220			
		(b) Hand trimming	m <sup>2</sup>	50			
58.02		Using machines for trimming or shaping (alternative to sub-item 58.01(a))					
		(a) Bulldozer	h	R/O			R/O
		(b) Motor grader	h	R/O			R/O
58.03		Preparing the areas for grassing:					
	LIC	(c) Topsoiling within the road reserve, where the following materials are used:					
		(1) Topsoil obtained from within the road reserve or borrow areas (free haul 1,0 km)	m <sup>3</sup>	30			
		(e) Providing and applying chemical fertilisers and/or soil-improvement material:					
		(iv) Formula 2:3:2 (22)	t	1			
		(f) Stockpiling of topsoil (free-haul 1,0 km)	m <sup>3</sup>	30			
B58.04		Grassing:					
		(c) Hydroseeding:	ha	0,40			
TOTAL CARRIED FORWARD TO SUMMARY							

Item	LI	Description	Unit	Quantity	Rate	Amount	R
						c	
59.00		FINISHING THE ROAD AND ROAD RESERVE AND TREATING OLD ROADS					
59.01		Finishing the road and road reserve: (b) Single carriageway road	km	1,0			
		SUPPORT FOR LV RETICULATION (UNDERGROUND SYSTEM) Poles Supply and install steel pole in excavated hole, including 1kV cable, cutting and scafing, kicking blocks, bonding, treating, etc.					
(a)		BS STEEL POLE, STEPPED 9m MH BUR, 76mm OD, C/W glandplate, MCB	No.	6,0			
(b)		Hole Excavations and Compaction Determination of pole positions, excavate, and supply a mechanical boring device if required. The rate shall include backfilling, compaction to 93% MOD AASHTO density, and where necessary the supply and transportation of suitable ground as may be required to receive the desired compaction, except where cement is specified. Any damage to existing services shall be made good by the Contractor at his own expense and to the approval of the PM(C). Hole for 9m pole - 1.2m deep	No.	6,0			
TOTAL CARRIED FORWARD TO SUMMARY							



Item	LI	Description	Unit	Quantity	Rate	Amount	R
<b>8100</b>		<u>TESTING MATERIALS AND WORKMANSHIP</u>					
		Other special tests requested by the Engineer:					
81.02		(a) Cost of testing	Prov sum	1,0	50000		50 000,00
		(b) Contractor's handling costs, profit and all other charges in respect of Sub-items B81.02 (a) above.	%	50000,0			
TOTAL CARRIED FORWARD TO SUMMARY							



## TABLE OF CONTENTS

	<b>PAGE NO.</b>
C3: SCOPE OF WORK.....	SW. 2
C3.1: STANDARD SPECIFICATIONS .....	SW. 2
C3.2: PROJECT SPECIFICATIONS .....	SW. 2
C3.3: PARTICULAR SPECIFICATIONS .....	SW. 72

## **C3: SCOPE OF WORK**

### **C3.1: STANDARD SPECIFICATIONS**

The Standard Specifications on which this contract is based are the **COLTO Standard Specifications for Road and Bridge Works for State Road Authorities 1998 edition**.

### **C3.2: PROJECT SPECIFICATIONS**

The Project Specifications, consisting of two parts, form an integral part of the Contract and supplement the Standard Specifications.

Part A contains a general description of the Works, the Site and the requirements to be met.

Part B contains variations, amendments and additions to the Standard Specifications and, if applicable, the Particular Specifications.

In the event of any discrepancy between a part or parts of the Standard or Particular Specifications and the Project Specifications, the Project Specifications shall take precedence. In the event of a discrepancy between the Specifications (including the Project Specifications) and the drawings and / or the Schedule of Quantities, the discrepancy shall be resolved by the Employer's Agent before the execution of the work under the relevant item.

The Standard Specifications, which form part of this contract, have been written to cover all phases of work normally required for road contracts, and they may therefore cover items not applicable to this particular contract.

## **PART A: GENERAL**

*[NOTE: This description is a broad outline of the Contract Works and does not limit the work to be executed by the Contractor in terms of the contract. The quantities of some of the major items indicated in this section are indicative, not absolute, and are provided to define in general terms the overall scope of the project. [For Compiler information purposes only]*

### **C3.2.1 Employer's Objective and Overview of the works**

The objectives of the project are to formulate effective engineering solutions for the CONSTRUCTION OF CREIGHTON TOWN UPGRADE (PHASE 2) to serve the communities of Creighton within the DR NKOSAZANA DLAMINI ZUMA Municipality.

The employer's objectives are also to deliver public infrastructure and services using labour-intensive methods in accordance with EPWP Guidelines.

Labour-intensive works comprise the activities such as those described in SANS 1921-5, Earthworks activities which are to be performed by hand, and its associated specification data. Such works shall be constructed using local workers who are temporarily employed in terms of this Scope of Work.

The Contractor shall be required to attend meetings of the local Project Liaison Committee (PLC) from time to time. Requirements of the Expanded Public Works Programme (EPWP) are contained in Part F of section C3.3 Particular Specifications. These requirements include provisions for the National Youth Service programme. Requirements in terms of Government's initiatives for broad based black economic empowerment with respect to small contractor development are contained in Part G of section C3.3 Particular Specifications.

### **C3.2.2 Overview of the works**

The scope of work is envisaged to include the following:

- Establishment of Contractors and Engineers Site Camp.
- Proving, exposing and relocation of various electricity, telecommunications, water and sewer services.

- Setting of delineators to separate and protect the travelling public from the construction activities.
- Accommodation of traffic.
- Clearing and grubbing of the road prism including the removal of trees.
- Construction of kerbs and channels and pipe culverts where indicated by the Engineer.
- Supply and install stormwater inlet and outlet structures as per issued drawings.
- Removal of existing structures and construction of new concrete walkway.
- Undertake earthworks and layer works.
- Construction of Bus shelter
- Finishing the roadway to facilitate "limited maintenance" such as cutting-back existing vegetation for the improvement of sight-distances and treatment to the shoulder edges for the prevention of silt build-up and improved run-off conditions.

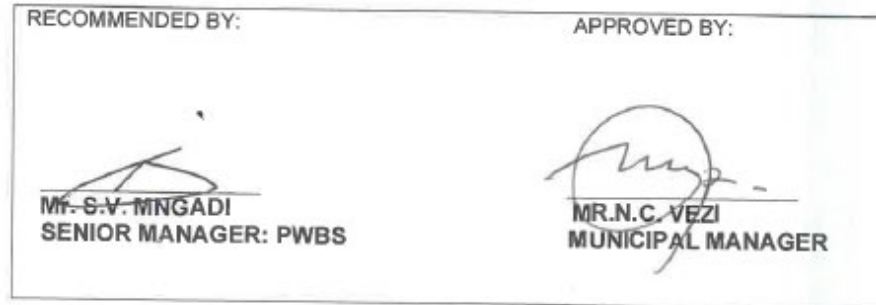

**C3.2.3 Location of site and access**

The project consists of the construction of 200m walkways as depicted in the Locality Plan.

**C3.2.4 Ground and Subsoil Investigations**

Geotechnical investigations have been undertaken on the site and the details of the subsoil conditions will be provided to the successful tenderer. Requests for the Geotechnical Investigations Report may be made by tenderers via email, should they require a copy of the report.

**C3.2.5 Ancillary works**

The existing asphalt roads are to be rehabilitated as depicted in the issued tender drawings.

**C3.2.6 Climatic conditions**

The proposed project area is in a high summer rainfall region with an average annual precipitation of 700 -1000 mm.

**C3.2.7 Labour**

A Project Liaison Committee will be established (as applicable) and is a vital means of communication between all parties involved with the project. The composition of the PLC comprises representatives of the Employer, the Engineer and formal structures within the community.

The Contractor shall make use of these communication channels and shall appoint from amongst his site personnel a responsible person to participate in the affairs of the PLC, and this representative will be also required to attend the monthly PLC meetings.

It is mandatory that the Contractor shall interact with the community via proactive project liaison and project participation by its leaders and constituted organisations and forums, as well as through the employment of its people, and these activities shall constitute essential facets of the project.

Local labour is to be used and the employment of such labour is to be done in conjunction with the PLC and in line with the Employer's policies.

Labour-intensive construction shall mean the economically efficient employment of as great a portion of labour as is technically feasible to produce a standard of construction as demanded by the specifications with completion by the Due Completion Date, thus bringing about the effective substitution of labour for plant and equipment.

Appropriate portions of the Works included in the Contract shall be executed using labour-intensive construction methods.

Except where the use of plant is essential in order, in the opinion of the Employer's Agent, to meet the specified requirements by the Due Completion Date, or where the use of plant is essential as a result of occupational health and safety considerations, the Contractor shall use only hand tools and equipment in the construction of those portions of the Works that are required in terms of these Project Specifications to be constructed using labour-intensive construction methods.

These portions of the Works shall be constructed utilizing only locally employed labour and/or the labour of local subcontractors, supplemented by the Contractor's key personnel to the extent necessary and unavoidable, unless otherwise instructed by the Employer's Agent and in accordance with the further provisions of the relevant sections of Portion B of the Project Specifications.

Subject to considerations of occupational health and safety, the portions of the Works to be executed using labour-intensive construction methods are:

- Clearing and grubbing of the Site;
- Excavation for structures up to 1,5 m deep;
- Bedding, selected fill, backfilling and compaction of all pipe trenches irrespective of depth, but assisted by mechanical compaction equipment in order to achieve the specified densities;
- Transportation and stockpiling (G7 material) and/or spoiling unsuitable trench materials;
- Landscaping;
- Excavation and compaction and gabion backfilling;
- Erosion Protection;
- Erection of road signs;
- Grass maintenance
- Mixing and placing of concrete; for concrete sidewalks, V-Drains, Kerb and Channel (Kerbs to be sourced from local suppliers where possible) or manufactured on site depending on the quantum required;
- Pipe Culverts;
- Headwalls using local materials;
- Road safety improvement;
- Alien vegetation removal;
- Construction of all brickwork required for structures; and
- Cleaning and tidying up of the Site.

In respect of those portions of the Works which are not listed above, the construction methods adopted and the plant utilized shall be at the discretion of the Contractor, provided always that the construction methods adopted and the plant utilized by the Contractor are appropriate in respect of the nature of the Works to be executed and the standards to be achieved in terms of the Contract.

Task Based Activities: Labour Intensive activities are to be planned as task based works where required. Task based refers to a specific amount of work to be performed which is clearly defined by a quantity and quality. Typically, a particular task can be completed within a working day.

#### **C.3.2.8 Spoiling of surplus material**

Surplus material shall be spoiled in designated areas approved by the Employer's Agent. The spoil material shall be disposed of in accordance with sub-clause 3306(f) of the COLTO standard specifications.

#### **C.3.2.9 Material sources, spoil and stockpile areas**

Where possible, the contractor shall source material from within 20km of the site utilizing local suppliers. The material which may be sourced locally:

- Cement;
- River sand (Coarse Grade Nom. 4.75mm); and
- 19mm sized crushed stone aggregates.

G5 material shall be obtained from commercial sources and/or a local borrow pit as applicable and provided the same has been tested and the subsequent results are favourable. A portion of the material will be available from the existing road prism.

Spoil areas and areas for the temporary stockpiling of construction materials shall be determined and agreed on site in conjunction with the Engineer, the PLC (where applicable) and the local communities (where applicable). The Contractor shall be permitted to use only these agreed spoil and stockpile areas, which shall be landscaped and vegetated on completion of the work.

#### **C.3.2.10 Accommodation of traffic**

The accommodation of traffic forms and integral part of the contract.

#### **C.3.2.11 Existing services**

The Contractor shall make himself acquainted with the position of all existing services before any excavation or other work likely to affect the existing services has commenced.

It is also expected that unknown domestic services crossings requiring relocation or protection may be encountered along the route as the work proceeds. The Contractor shall make every effort to establish the location of these services in any area prior to excavations commencing in that area. Such efforts shall include diligent enquiry and discussions with adjacent landowners, visual surface inspection and exploratory trenching investigation as necessary.

The Contractor will be held responsible for any damage to known existing services caused by or arising out of his operations and any damage shall be made good at his own expense. Damage to unknown services shall be repaired as soon as possible and liability shall be determined on site when such damage should occur.

#### **C.3.2.12 Employer's Agent's site offices and laboratory**

The Contractor shall be required to provide furnished site office facilities, laboratory facilities, ablution facilities, and carpools for the Engineer at a site located in close proximity to the Contractor's office establishment and to the Works. A possible area for such site establishment shall be indicated by the Engineer before the commencement of construction.

#### **C.3.2.13 Temporary Works**

Vertical, horizontal and inclined falsework and formwork will be used during the construction of the culvert structures. Provisions of access scaffolding and temporary propping will also be required. Temporary shoring will be utilised on unstable excavations.

The Temporary Works required under this Contract shall include the traffic accommodation measures implemented, the provision of drainage control, falsework and formwork during the construction of the minor drainage structures, and the provision of any scaffolding or temporary propping used during the erection of the road signs.

All Temporary Works shall be removed from the Site on completion of the Contract.

#### **C.3.2.14 Maintenance of the Works during the construction period**

The Contractor shall take note of the various requirements of the General Conditions of Contract 2015 and the standard specifications with respect to the care and protection of the Works.

The handing-over of the road reserve for this contract is described later in the Project Specifications. The Contractor shall be responsible for maintaining this portion of the road from the date of hand-over until the issue of the Certificate of Practical Completion.

**C.3.2.15 Testing of materials**

A provisional sum has been allowed in section 8100 of the Schedule of Quantities for all acceptance control testing laboratory work to be carried out by the Engineer using the laboratory facilities included in section 1400 and/or commercial laboratory facilities.

The Contractor shall carry out at his own cost the required process control testing as specified in terms of the COLTO standard specifications.

**C.3.2.16 Power supply and other services**

The Contractor shall make his own arrangements concerning the supply of electrical power and all other services. No direct payment shall be made for the provision of electrical and other services. The cost thereof shall be deemed to be included in the rates and amounts tendered for the various items of work for which these services are required.

**C.3.2.17 Construction in confined areas**

The works are to be undertaken in a sparsely populated area with sugar cane crop. It is thus inevitable for the Contractor to work within confined areas. Except where provided for in the specifications, no additional payment shall be made for work done in restricted areas. In certain places the width of the fill material and pavement layers may decrease to zero and the working space may be confined. The method of construction in these confined areas largely depends on the Contractor's constructional plant.

However, the Contractor shall note that, unless otherwise provided for in terms of the scheduled payment items in the COLTO Standard Specifications or these project specifications, measurement and payment shall be in accordance with the specified cross sections and dimensions only, irrespective of the method used for achieving these cross sections and dimensions, and that the tendered rates and amounts shall include full compensation for all special equipment and construction methods and for all difficulties encountered when working in confined areas and narrow widths, and at or around obstructions, and that no extra payment shall be made nor shall any claim for additional payment be considered in such cases.

**C.3.2.18 Contractor's campsite**

Possible locations for a campsite shall be pointed out at the clarification meeting.

The Contractor shall make his own arrangements for the provision of his campsite and housing for construction personnel but the chosen site shall be subject to the approval of the Engineer, the local authorities and, where applicable, the Project Liaison Committee (PLC) associated with the project.

The standard of the Contractor's camp, offices, accommodation, ablution, and other facilities must comply with the requirements of all local authority, environmental and industrial regulations concerned. In establishing and maintaining his campsite, due cognisance is to be taken of the requirements of the Project Specifications. The Contractor is to fully familiarise himself with all local by-laws and Government regulations for the employment, transport and accommodation of labour on site.

The Contractor shall particularly note that there is a high risk of theft, vandalism and damage to property in this area and strict security will be required for all plant, establishment, temporary works and partially completed works. The Contractor shall be responsible for providing security for all plant, establishment, temporary works and partially completed works.

No separate payment shall be made for the provision of such security since full compensation for these costs shall be deemed to be included in the amount tendered for item B13.01(c) (The



contractor's general obligations: Time-related obligations).

### **C.3.2.19 Additional requirements for construction activities**

The travelling public shall have the right of way on public roads, and the Contractor shall make use of approved methods to control the movement of his equipment and vehicles so as not to constitute a hazard on the road.

The Contractor's tendered rates shall include full compensation for all costs which may arise from the construction and maintenance of deviations and construction under traffic. No claim for additional costs which may arise from these methods of traffic accommodation and no additional payment owing to inconvenience as a result of the Contractor's method of working shall be considered.

### **C3.2.20 Design**

- The Contractor is responsible for the Temporary Works, Site Camp and Contractor's office accommodation design.
- Site layouts for the Engineer Representative's temporary office accommodation and a Monthly Meeting venue.

The costs of the designs will be deemed to have been included in the scheduled items in the Schedule of Quantities. No other additional payments will be certified to cover these activities.

The bid drawings are applicable to the contractor are detailed in this tender document. These drawings have been used for setting up the Bills of Quantities.

### **C3.2.21 Quality Assurance (QA) *(Read with SANS 1921 – 1: 2004 clause 4.4)***

The Contractor will be solely responsible for the production of work that complies with the Specifications to the satisfaction of the Engineer. To this end it will be the full responsibility of the Contractor to institute an appropriate Quality Assurance (QA) system on site. The Engineer will audit the Contractor's quality assurance (QA) system on a regular basis to verify that adequate independent checks and tests are being carried out and to ensure that the Contractor's own control is sufficient to identify any possible quality problems which could cause a delay or failure.

The Contractor shall ensure that efficient supervisory staff, the required transport, instruments, equipment and tools are available to control the quality of his own workmanship in accordance with his QA-system. His attention is drawn to the fact that it is not the duty of the Engineer or the Engineer's representative to act as foreman or surveyor.

### **C3.2.22 Programme in terms of Clause 5.6 of the General Conditions of Contract**

It is essential that the construction programme, which shall conform in all respects to Clause 5.6 of the General Conditions of Contract, be furnished within the time stated in the Contract Data. The preliminary programme to be submitted with the tender shall be used as basis for this programme.

### **C.3.2.23 Construction programme**

In addition to any other restrictions accommodated by the Contractor in compiling the construction programme, the following constraints shall be taken into account in the preparation thereof:

- (1) The whole of the Works (and the portions of the Works if completion in portions is required) shall be completed within the time period(s) stated (refer to the Contract Data in section C1.2.2).
- (2) Working days lost due to abnormal rainfall shall be treated as set out in clause B1215.
- (3) Allowance shall be made for non-working days and special non-working days (refer to the Contract Data in section C1.2.2).
- (4) Construction activities must comply with all the specified environmental requirements including clause B1233 and the requirements of Part C: Environmental Management Specification

contained in section C3.3 Particular Specifications.

- (5) Construction activities must comply with all the specified health and safety obligations including the requirements of the OHS 1993 Health and Safety Specifications.
- (6) Strict control of access to and from local public roads shall be required when construction vehicles, plant or equipment leave or enter the site.
- (7) Throughout the contract period traffic must be accommodated through the sites and all other contractors engaged on the CONSTRUCTION OF HIMEVILLE ASPHALT SURFACING ROADS (PHASE 3) must be accommodated.
- (8) The Contractor's programme of work shall take due cognisance of risks by limiting the duration of the exposure of the various construction elements to natural phenomena.
- (9) Programme must clearly indicate work carried out by the nominated sub-contractors and its impact on the contractors works programme

For the guidance of Tenderers, a provisional preliminary construction programme is included below. This programme is given in good faith and no claims shall be entertained due to inaccuracies, discrepancies or omissions contained in the programme.

**PRELIMINARY CONSTRUCTION PROGRAMME**

ACTIVITY	DURATION	Month 1				Month 2				Month 3				Month 4				Month 5				Month 6			
	(Weeks)																								
1. Site Establishment																									
2. Relocation of Services																									
3. Traffic Accommodation																									
4. Clear and Grub																									
5. Earthworks																									
6. Drainage																									
7. Subsoils																									
8. Kerb and channel																									
9. Selected Subgrade																									
10. Cemented Subbase																									
11. Crushed Stone Base																									
12. Surfacing																									
13. Ancillary Items																									
14. Finishing Road Reserve																									
15. Pedestrian Sidewalks																									
16. De-Establishment																									
17. Road Marking																									
EXPECTED CASH FLOWS	(in Rands)																								

**C.3.2.24 Management and disposal of water** (Read with SANS 1921 - 1 : 2004 clause 4.6)

The Contractor shall pay special attention to the management and disposal of water and stormwater on the site. It is essential that all completed works or parts thereof are kept dry and properly drained. Claims for delay and for repair of damage caused to the works as a result of the Contractor's failure to properly manage rain and surface water, will not be considered.

**C.3.2.25 Earthworks** (Read with SANS 1921 - 1 : 2004 clause 4.10)

**Borrow pits and spoil areas**

The borrow pits to be used for this contract, where possible, shall be pointed out at the Compulsory Site Inspection. It is however the contractor's responsibility to locate the closest borrow pit which will be tested by an approved Geotechnical Engineering specialist prior to the source being used. The rate for gravel material shall be deemed to include all overhaul based on the identified borrow pits' distance.

The Contractor shall be permitted to use only those borrow pits approved by the Engineer. The spoil sites shall be determined on site in conjunction with the Engineer and the Municipality. The Contractor shall be permitted to use only those spoil areas approved by the Engineer. Should the Contractor wish to use any other tip area for the disposal of soil, rubble, vegetation, etc., its use shall be subject to the approval of the Engineer and the landowner.

**C.3.2.26 Testing** (Read with SANS 1921 - 1 : 2004 clause 4.11)

**Process control**

The Contractor shall arrange for all tests required for process control to be done by a laboratory acceptable to and approved by the Engineer.

The Contractor may establish his own laboratory on site or he may employ the services of an independent commercial laboratory. Whatever method is used, the Contractor must submit the results of tests carried out on materials and workmanship when submitting work for acceptance by the Engineer. The costs for these tests shall be deemed to be included in the relevant rates and no additional payment will be made for testing as required.

**Acceptance control**

The process control test results submitted by the Contractor for approval of materials and workmanship may be used by the Engineer for acceptance control. However, before accepting any work, the Engineer may have further control tests carried out by a laboratory of his choice. The cost of such additional tests will be covered by a provisional sum provided in the schedule of quantities, but tests that failed to confirm compliance with the specifications, will be for the account of the Contractor.

**C.3.2.27 Accommodation of Employees**

No employees except for security guards will be allowed to sleep or be accommodated on the site in urban areas.

No housing is available for the Contractor's employees and the Contractor shall make his own arrangements to house his employees and to transport them to site.

No informal housing or squatting will be allowed.

The Contractor shall provide the necessary ablution facilities at his camp site and the site of the works for the use of his employees. Chemical toilets only will be allowed where temporary facilities have to be provided.

**C.3.2.28 Survey beacons** (Read with SANS 1921 - 1 : 2004 clause 4.15)

The Contractor shall take special precautions to protect all permanent survey beacons or pegs

such as bench-marks, stand boundary pegs and trigonometrical beacons, regardless whether such beacons or pegs were placed before or during the execution of the Contract. If any such beacons or pegs have been disturbed by the Contractor or his employees, the Contractor shall have them replaced by a registered land surveyor at his own cost.

**C.3.2.29 Health and Safety** *(Read with SANS 1921 - 1: 2004 clause 4.18)*

**C.3.2.29.1 General statement**

It is a requirement of this contract that the Contractor shall provide a safe and healthy working environment and to direct all his activities in such a manner that his employees and any other persons, who may be directly affected by his activities, are not exposed to hazards to their health and safety. To this end the Contractor shall assume full responsibility to conform to all the provisions of the Occupational Health and Safety Act No 85 and Amendment Act No 181 of 1993, and the OHS Act 1993 Construction Regulations 2003 issued on 18 July 2003 by the Department of Labour.

For this contract the Contractor is required to confirm his status as mandatory and employer in his own right for the execution of the contract by entering into an agreement with the Employer in terms of the Occupational Health and Safety Act in the form as included in section C1.2.4

**C.3.2.29.2 Health and Safety Specifications and Plans**

(a) Employer's Health and Safety Specification

The Employer's Health and Safety Specification will be included in the tender documents as part of the Project Specifications.

*[Note to compiler: The Employer's Safety Specification is available and must be included]*

(b) Tenderer's Health and Safety Plan

The Tenderer shall submit with his tender his own documented Health and Safety Plan he proposes to implement for the execution of the work under the contract. His Health and Safety Plan must at least cover the following:

- i. a proper risk assessment of the works, risk items, work methods and procedures in terms of Regulations 7 to 28;
- ii. pro-active identification of potential hazards and unsafe working conditions;
- iii. provision of a safe working environment and equipment;
- iv. statements of methods to ensure the health and safety of subcontractors, employees and visitors to the site, including safety training in hazards and risk areas (*Regulation 5*);
- v. monitoring health and safety on the site of works on a regular basis, and keeping of records and registers as provided for in the Construction Regulations;
- vi. details of the Construction Supervisor, the Construction Safety Officers and other competent persons he intends to appoint for the construction works in terms of Regulation 6 and other applicable regulations; and
- vii. details of methods to ensure that his Health and Safety Plan is carried out effectively in accordance with the Construction Regulations 2003.

The Contractor's Health and Safety Plan will be subject to approval by the Employer, or amendment if necessary, before commencement of construction work. The Contractor will not be allowed to commence work, or his work will be suspended if he had already commenced work, before he has obtained the Employer's written approval of his Health and Safety Plan.

Time lost due to delayed commencement or suspension of the work as a result of the Contractor's failure to obtain approval for his safety plan, shall not be used as a reason to claim for extension of time or standing time and related costs

**C.3.2.29.3 Cost of compliance with the OHS Act Construction Regulations**

The rates and prices tendered by the Contractor shall be deemed to include all costs for conforming to the requirements of the Act, the Construction Regulations and the Employer's Health and Safety Specification as applicable to this contract.

Should the Contractor fail to comply with the provisions of the Construction Regulations, he will be liable for penalties as provided in the Construction Regulations and in the Employer's Health and Safety Specification.

**C.3.2.29.4 Management of the environment** (Read with SANS 1921 - 1: 2004 clause 4.19)

Respect for the environment is an important aspect of this contract and the Contractor shall pay special attention to the following:

(a) Natural Vegetation

The Contractor shall confine his operation to the limits of the road reserve for constructing the works and where applicable detours, shall be sited in consultation with the Engineer and the local communities.

Only those trees and shrubs directly affected by the works and those the Engineer may directly instruct, shall be cut down and stumped. The natural vegetation, grassing and other plants shall not be disturbed other than in areas where it is essential for the execution of the work or where directed by the Engineer.

(b) Fires

The Contractor shall comply with the statutory and local fire regulations. He shall also take all necessary precautions to prevent any fires. In the event of fire, the Contractor shall take active steps to limit and extinguish the fire and shall accept full responsibility for damages and claims resulting from such fires which may have been caused by him or his employees.

(c) Environmental Management Plan

In addition to the above all requirements according to the Environmental Management Framework prepared by the Municipality, and the project specific Environmental Management Plan will be adhered to.

**C.3.2.30 EPWP Alignment Clauses**

**C.3.2.30.1 (1.2) Personal & Other Protective Equipment** (Sections 8/15/23 or the OHS Act)

The Contractor is required to identify the hazards in the workplace and deal with them. He must either remove them or, where impracticable take steps to protect workers and make it possible for them to work safely and without risk to health under the hazardous conditions.

Personal Protective equipment (PPE) should, however, be the last resort and there should always first be an attempt to apply engineering and other solutions to mitigating hazardous situations before the issuing of PPE is considered.

Where it is not possible to create an absolutely safe and healthy workplace the Contractor is required to inform employees regarding this and issue, free of charge, suitable equipment to protect them from any hazards being present and that allows them to work safely and without risk to health in the hazardous environment.

It is a further requirement that the said equipment be maintained by the Contractor, that he instructs and trains the employees in the use of the equipment and ensures that the prescribed equipment is used by the employee/s.

Employees do not have the right to refuse to use/wear the equipment prescribed by the employer and, if it is impossible for an employee to use or wear prescribed protective equipment through health or any other reason, the employee cannot be allowed to continue working under the hazardous condition/s for which the equipment was prescribed but an alternative solution has to be found that may include relocating or discharging the employee. The Contractor may not charge any fee for protective equipment prescribed by him/her but may charge for equipment under the following conditions:

- Where the employee requests additional issue in excess of what is prescribed

- Where the employee has patently abused or neglected the equipment leading to early failure
- Where the employee has lost the equipment

All employees shall, as a minimum, be required to wear the following PPE on any infrastructure projects:

Protective overalls

- Protective footwear
- Protective headwear
- Eye/face protection

All PPE provided to local labour working on the Expanded Public Works Programme shall be branded in accordance with the EPWP CI Manual. Typical elements which shall be branded include:

- Protective overalls
- Reflective vests
- Protective headwear

The rate for local labour shall include for the supply of EPWP branded PPE in accordance with the Provincial EPWP specifications. The rate shall include the additional cost of the specified colours for the PPE and branding in accordance with CI manual.

#### **C.3.2.30.2 (B1200 (e)) COMMUNITY LIAISON OFFICER (CLO)**

The contractor or his appointed agent will appoint a Community Liaison Officer (CLO) after consultation with the local communities, the engineer and the employer. The contractor shall direct all his liaison efforts with the local communities through the appointed officer. The contractor shall, however, accept the appointed as part of his management personnel.

(a) Duties of the Community Liaison Officer

The Community Liaison Officer's duties will be:

- (i) To be available on site daily between the hours of \_\_\_(insert time) and \_\_\_(insert time) and at other time as the need arises. His normal working day will extend from \_\_\_morning until \_\_\_(insert time) in the afternoon.
- (ii) To determine, in consultation with the contractor, the needs of the temporary labour for relevant skills training. He will be responsible for the identification of suitable trainees and will attend one of each of the training sessions.
- (iii) To communicate daily with the contractor and the engineer to determine the labour requirements regarding numbers and skill, to facilitate in labour disputes and to assist in their resolution.
- (iv) To assist in and facilitate in the recruitment of suitable temporary labour and the establishment of a "labour desk".
- (v) To attend all meetings in which the community and/or labour are present or are required to be represented.
- (vi) To assist in the identification, and screening of labourers from the community in accordance with the contractor's requirements.
- (vii) To inform temporary labour of their conditions of temporary employment and to inform temporary labourers as early as possible when their period of employment will be terminated.
- (viii) To attend disciplinary proceedings to ensure that hearings are fair and reasonable.
- (ix) To keep a daily written record of his interviews and community liaison.
- (x) To attend monthly site meetings to report on labour and RDP matters.
- (xi) All such other duties as agreed upon between all parties concerned.
- (xii) To submit monthly returns regarding community liaison.

(b) Payment for the community liaison officer

A special pay item is incorporated in section 1200 of the bill of quantities relating to payment of the liaison officer on a prime cost sum basis. This payment shall only be made for the period for which the duties of the liaison officer are required and not necessarily for the full duration of the contract. The remuneration of the CLO shall be determined jointly by the contractor, engineer and employer.

(c) Period of employment of the community liaison officer

The period of employment of the community liaison officer shall be as decided upon jointly by the contractor, engineer and employer.



**PART B: AMENDMENTS TO THE STANDARD SPECIFICATIONS**

**PROJECT SPECIFICATIONS RELATING TO THE STANDARD SPECIFICATIONS AND OTHER ADDITIONAL SPECIFICATIONS**

In certain clauses in the COLTO Standard Specifications, allowance is made for a choice to be specified in the Project Specifications between alternative materials or methods of construction, and for additional requirements to be specified to suit a particular contract. Details of such alternatives or additional requirements applicable to this Contract are contained in this part of the Project Specifications. It also contains the necessary additional specifications required for this Contract.

The clauses and payment items dealt with in this part of the Project Specifications are numbered 'B' with a number corresponding to the relevant clause or item number in the COLTO Standard Specifications.

New clauses and payment items not covered by clauses or items in the COLTO Standard Specifications have been included here and have also been designated with the prefix 'B'. Such clauses and items have been given a new number following upon the last number used in the particular section referred to in the COLTO Standard Specifications.

(a) The following specifications shall apply to this contract:

The COLTO Standard Specifications for Road and Bridge Works for State Road Authorities (1998).

The contractor may purchase copies from the South African Institution of Civil Engineers at:

**SAICE**

Waterfall Park / Postnet Suite 81  
Howick Gardens/ Private Bag X65  
Vorna Valley / Halfwayhouse  
Becker Street/ 1685  
Midrand

Tel: (011) 805-5947  
Fax: (011) 805-5971

(b) SANS or BS Specifications and Codes of Practice

Wherever any reference is made to the South African National Standards(SANS) and the British Standards Specification (BSS) in either these Bill of Quantities or the Specification of Materials and Methods to be Used (OOG-001E), this reference shall be deemed to read "SANS or equivalent standard" and BS or equivalent standard" respectively.

(c) Various other specifications specified in the COLTO Standard Specifications or the Project Specifications.

## **SECTION 1100: DEFINITIONS AND TERMS**

***In all cases where “Directorate Land Transport” appears in the text or in drawings contained in this document it shall be read as “Province of KwaZulu-Natal”.***

### **B1115 GENERAL CONDITIONS OF CONTRACT**

*Replace clause 1115 with the following:*

“The General Conditions of Contract for Construction Works, 3<sup>rd</sup> edition 2015 (abbreviated elsewhere in C3.2 Project Specifications and C3.3 Particular Specifications as “GCC 2015” or as “General Conditions of Contract 2015”) published by the South African Institution of Civil Engineering (SAICE), together with the Special Conditions of Contract form part of the contract.

All references in the COLTO Standard Specifications for Road and Bridge Works are to the COLTO General Conditions of Contract for Road and Bridge Works for State Road Authorities. Consequently, all references in the COLTO Standard Specifications have to be amended accordingly to reflect the appropriate General Conditions of Contract relevant to the Contract. The COLTO Standard Specifications have been scrutinized and the clauses, which refer to the COLTO General Conditions of Contract, identified. Each COLTO clause reference is tabulated in Table B1115 below (context of reference is also given) together with the relevant equivalent clause in the SAICE General Conditions of Contract for Construction Works 3rd edition 2015 applicable for this contract.

Whereas every effort has been made to include all of the affected clauses in the table, there may be some omissions. In every case, however, the SAICE General Conditions of Contract for Construction Works 3rd edition 2015 reference, as amended by the Special Conditions of Contract in the Contract Data, shall apply and the Contractor shall be responsible for interpretation of the equivalent clause.

The COLTO Standard Specifications make frequent use of the term “engineer”. The Project Specifications and the Schedule of Quantities in turn make reference to the COLTO Standard Specifications and may use similar terminology in order to facilitate the reading and cross-referencing thereof.

Wherever in the COLTO Standard Specifications or in the Project Specifications or in the Schedule of Quantities reference is made to the “engineer” or the “Engineer”, this is to be interpreted as the “Employer’s Agent” as defined in subclause 1.1.1.16 of GCC 2015.

Wherever in the COLTO Standard Specifications or in the Project Specifications or in the Schedule of Quantities reference is made to the “engineer’s representative” or the “Engineer’s Representative”, this is to be interpreted as the “Employer’s Agent’s Representative” as defined in subclause 1.1.1.17 of GCC 2015.”

**TABLE B1115: REFERENCES IN COLTO STANDARD SPECIFICATIONS TO THE COLTO GENERAL CONDITIONS OF CONTRACT AND RELEVANT SAICE GENERAL CONDITIONS OF CONTRACT FOR CONSTRUCTION WORKS 3<sup>rd</sup> EDITION 2015**

COLTO Standard Specification		COLTO General Conditions of Contract 1998		SAICE General Conditions of Contract for Construction 3 <sup>rd</sup> Edition 2015	
Clause No.	Page No.	Clause No.	Description or Reference	Clause No.	Description or Reference
1202	1200-2	15	Programme	5.6	Programme
1209(e)	1200-5	52: 52(1)(e) 52(2)	Monthly payments (documentary evidence of ownership of materials) Valuation of material brought onto Site	6.9 & 6.10: 6.9 6.10.2	Vesting of Plant and materials Valuation of material brought onto Site
1210	1200-5	54: 54(1) 54(2) 54(3)	Certificate of Practical Completion	5.14: 5.14.1 5.14.2 5.14.3	Certificate of Practical Completion
1212(l)	1200-7	49: 49(2)	Application of Contract Price Adjustment Factor	6.8: 6.8.2	Application of the Contract Price Adjustment Factor
1215	1200-9	45	Extension of time for completion	5.12	Extension of time for Practical Completion
1217	1200-10	35	Care of the Works	8.2	Care of the Works
1303	1300-1 and 1300-2	49 & 53: 49(2) and 49(3) 53	Application of Contract Price Adjustment Factor and Variation in cost of special materials Variations exceeding 20 per cent	6.8 & 6.11: 6.8.2 and 6.8.3 6.11	Application of the Contract Price Adjustment Factor and Variation in cost of special materials Variations exceeding 15 per cent
1303	1300-2	12 & 45: 12 45	Commencement of Works and Commencement Date Extension of time for completion	5.3 & 5.12: 5.3 5.12	Commencement of the Works Extension of time for Practical Completion
1403 (c)(ii)	1400-4	40(1)	Valuation of variations	6.4.1	Valuation of variations
1505	1500-3	40: 40(1)	Valuation of variations	6.4: 6.4.1	Valuation of variations
1517 Items: 15.08 15.09 15.11	1500-8	48: 48.1	Provisional Sums	6.6: 6.6.1	Provisional sums
3108 Note (2)	3100-4	40: 40(1)	Valuation of variations	6.4: 6.4.1	Valuation of variations
3204 (b)(iii)	3200-2	40: 40(1)	Valuation of variations	6.4: 6.4.1	Valuation of variations

COLTO Standard Specification		COLTO General Conditions of Contract 1998		SAICE General Conditions of Contract for Construction 3 <sup>rd</sup> Edition 2015	
Clause No.	Page No.	Clause No.	Description or Reference	Clause No.	Description or Reference
3303(b)	3300-2	2	Engineer and Engineer's Representative	3.	Employer's Agent
5803(c)	5800-3	40: 40(1)	Valuation of variations	6.4: 6.4.1	Valuation of variations
5805(d)	5800-4	40: 40(1)	Valuation of variations	6.4: 6.4.1	Valuation of variations
5809 Item 58.10	5800-10	48: 48.1	Provisional Sums	6.6: 6.6.1	Provisional sums
8103(c)	8100-1	40: 40(1)	Valuation of variations	6.4: 6.4.1	Valuation of variations
8117 Item 81.03	8100-26	22	Clearance of Site on completion	5.15	Clearance of Site

## **SECTION 1200: GENERAL REQUIREMENTS AND PROVISIONS**

### **B1202 SERVICES**

*Add the following at the end of clause 1202:*

"A provisional sum is included in the Schedule of Quantities to cover the costs of relocating the known services. This provisional sum shall be used to effect payments for the services relocation work carried out by the subcontractor selected by the Contractor in consultation with the Employer for this purpose."

### **B1205 WORKMANSHIP AND QUALITY CONTROL**

*Add the following paragraph to the end of clause 1205:*

"Testing for quality control shall be conducted in accordance with the requirements of Section 8200 for Quality Control (Scheme 1)."

### **B1206 THE SETTING-OUT OF WORK AND PROTECTION OF BEACONS**

*Delete the first paragraph of clause 1206 in its entirety and replace it with the following:*

"The Contractor shall comply with all legal provisions in regard to surveying and setting out work."

*Add the following paragraph to the end of clause 1206:*

"It may become necessary to construct, level and coordinate new survey beacons during the course of the contract, or to protect existing survey beacons. A provisional sum is included in the Schedule of Quantities to cover the costs of such work."

### **B1209 PAYMENT**

#### **(a) Contract rates**

*Add the following new paragraph at the end of subclause 1209(a):*

"All rates tendered are to be exclusive of VAT."

### **B1212 ALTERNATIVE DESIGNS AND OFFERS**

*Add the following to the end of subclause 1212(m):*

"The provision for contract price adjustment in the original Tender Summary must not under any circumstances be altered in an alternative offer."

### **B1215 EXTENSION OF TIME RESULTING FROM ABNORMAL RAINFALL**

Extension of time resulting from abnormal rainfall shall be calculated according to the requirements of Method (ii) (Critical-path method).

#### **Method (ii) (Critical-path method)**

*Delete the words "(based on a five-day working week)" in the fifth and sixth lines of the second paragraph of Method (ii).*

*Add the following to the end of Method (ii):*

"The value of "n" working days expected delay caused by normal rainy weather as referred to in Method (ii) shall be as given in Table B1215 below for each respective calendar month of any year:

**Table B1215**

Month	Expected delay of "n" working days due to normal rainy weather	Month	Expected delay of "n" working days due to normal rainy weather
January***	8	July	1
February	6	August	1
March	5	September	2
April	5	October	3
May	2	November	4
June	1	December***	5

\*\*\* Includes the whole month of December / January.

Each "n"-value in Table B1215 applies only to the calendar month immediately to the left of the number, and the "n"-values as specified shall not be taken as being carried forward so as to accumulate over the contract period. If no abnormal rainfall occurs during a particular calendar month in a particular year, then no extension of time for abnormal rainfall shall be granted with respect to that calendar month for that year, and no further consideration shall be given to that "n"-value in respect of that year.

Similarly, if the "n" working days expected delay caused by normal rainy weather during a particular calendar month in a particular year (for which the Contractor shall have made provision in his programme of work in accordance with Method (ii)) are not taken up (either in whole or in part) by standing time due to normal rainy weather during that month of that year, then no further consideration shall be given to those "n" working days (or portion thereof), which effectively have been gained, when any subsequent extension of time claims which may arise later during the contract period are assessed by the Employer's Agent."

**B1219 WATER**

*Add the following paragraph to the end of clause 1219:*

"The Contractor shall arrange for chemical tests to be carried out to confirm the suitability of his proposed water sources for use as drinking water and for use in the concrete construction. The Contractor shall ensure that these tests also include testing for salinity and sugar content levels.

The Contractor shall note that the necessary permission must be obtained from the Department of Water Affairs for the abstraction of water from streams and rivers."

**B1224 THE HANDING-OVER OF THE ROAD RESERVE**

*Add the following paragraph to the end of clause 1224:*

"The handing-over of the road reserve for this project shall be subject to the following restrictions:

- (a) Only that portion of the road reserve from km 13.220 to km 20.360 shall be handed over to the Contractor. The Contractor shall be responsible for the maintenance along this portion of the road until completion of the contract.
- (b) The Contractor shall be required to accommodate public traffic as well as the Employer's other contractors working on various projects in the area related to the construction of Main Road 258
- (c) The Contractor shall be required to accommodate service owners and other contractors working on the services relocation and maintenance in the execution of their duties."

**B1229 SABS CEMENT SPECIFICATIONS**

*Add the following paragraphs to the end of clause 1229:*

"All cement used on this contract shall comply with SANS 50197-1: Cement Part 1: Composition, specifications and conformity criteria for common cements.

Where reference is made in these Project Specifications or in the COLTO Standard Specifications to the former SABS cement specifications (e.g., SABS 471, SABS 626, SABS 831, SABS 1491), such reference shall be replaced with the new specification:

- SANS 50197-1: Cement Part 1: Composition, specifications and conformity criteria for common cements.

The blending of cements on site shall not be permitted.”

*Add the following new clauses at the end of Section 1200:*

### **"B1230 DEVELOPMENT PROGRAMME**

A Project Liaison Committee (PLC) is a vital means of communication between all parties involved with the project. The PLC comprises representatives of the Employer, the Employer's Agent and formal structures within the Community. The Contractor shall make use of these communication channels, and shall appoint from amongst his site personnel a responsible person to participate in the affairs of the PLC, and this representative shall also attend the monthly PLC meetings when so requested.

### **B1231 COMMUNITY PARTICIPATION**

#### **Purpose:**

In order to give effect to the need for participation and transparency in the process of appointing labour, the community should participate in the decision making process throughout the life of a project. This shall be achieved through structured engagement between those responsible for the delivery of the project and the community.

#### **Structure and Composition:**

A Project Liaison Committee (PLC) may be formed from representatives of the Employer, the Engineer, the Contractor and the Community if the project is such that a specific community can be identified.

#### **Procedures:**

- The PLC deals with labour and SMME involvement on the project and shall meet at least once every month until such time as it is of the opinion that it could fulfil its tasks by meeting less frequently.
- The PLC shall make recommendations by consensus. If consensus cannot be reached, the decision of the Employer will be final in cases that have no financial implications for the Contractor or where payment is to be made from PC items. Where the financial responsibility for the successful completion of the works rests with the Contractor, the Contractor's decision shall be final. In fulfilling its tasks, the PLC shall be guided by the relevant sections of this specification and the supplementary documents.

#### **Tasks of the PLC**

- To assist with community liaison and resolution of disputes.
- To devise fair and transparent procedures that will assist the Contractor in the engagement of labour and the award of sub-contracts to SMME's.
- To advise on and monitor labour issues.
- To assist in resolving labour disputes.

#### **Assistance to the PLC**

- The Employer may appoint a competent local person as a Community Liaison Officer to assist the Engineer and the Contractor in the day to day liaison with the communities directly affected by the project.

### **B1232 COMMUNITY LIAISON OFFICER (CLO)**

The contractor or his appointed agent will appoint a Community Liaison Officer (CLO) after consultation with the local communities, the engineer and the employer. The contractor shall direct all his liaison efforts with the local communities through the appointed officer. The contractor shall, however, accept the appointed as part of his management personnel.

#### **(a) Duties of the Community Liaison Officer**

The Community Liaison Officer's duties will be:

- (i) To be available on site daily between the hours of 07h30 and 16h30 and at other time as the need arises. His normal working day will extend from 07h30 morning until 16h30 in the afternoon.
- (ii) To determine, in consultation with the contractor, the needs of the temporary labour for relevant skills training. He will be responsible for the identification of suitable trainees and will attend one of each of the training sessions.
- (iii) To communicate daily with the contractor and the engineer to determine the labour requirements with regard to numbers and skill, to facilitate in labour disputes and to assist in their resolution.
- (iv) To assist in and facilitate in the recruitment of suitable temporary labour and the establishment of a "labour desk".
- (v) To attend all meetings in which the community and/or labour are present or are required to be represented.
- (vi) To assist in the identification, and screening of labourers from the community in accordance with the contractor's requirements.
- (vii) To inform temporary labour of their conditions of temporary employment and to inform temporary labourers as early as possible when their period of employment will be terminated.
- (viii) To attend disciplinary proceedings to ensure that hearings are fair and reasonable.
- (ix) To keep a daily written record of his interviews and community liaison.
- (x) To attend monthly site meetings to report on labour and RDP matters.
- (xi) All such other duties as agreed upon between all parties concerned.
- (xii) To submit monthly returns regarding community liaison as illustrated in Part C5.1 of this document (form RDP 12(E)).

**(b) Payment for the community liaison officer**

A special pay item is incorporated in section 1200 of the bill of quantities relating to payment of the liaison officer on a prime cost sum basis. This payment shall only be made for the period for which the duties of the liaison officer are required and not necessarily for the full duration of the contract. The remuneration of the CLO shall be determined jointly by the contractor, engineer and employer.

**(c) Period of employment of the community liaison officer**

The period of employment of the community liaison officer shall be as decided upon jointly by the contractor, engineer and employer.

**B1233 UNEMPLOYMENT INSURANCE FUND**

The contractor will be responsible for payment or contribution of UIF for all labour employed under the project. Proof of payment of UIF shall be available upon request.

**B1234 COMPENSATION FOR OCCUPATIONAL INJURIES AND DISEASES ACT, 1993**

All labour employed on the site shall be covered by the Compensation for Occupational Injuries and Diseases Act, 1993, as amended. The Contractor shall pay in full, including the payment of the necessary levies, such amounts as are due in terms of the Act. The manner in which compensation in terms of this Act shall be handled shall be resolved by the Contractor at the commencement of the contract.

**B1235 COMPLIANCE WITH THE ROAD TRAFFIC ACT**

When a service necessitates vehicles or plant travelling or working on a public road, the following shall apply:

- The vehicles and plant shall be licensed in terms of the National Road Traffic Act 1996 (Act No. 93 of 1996) as amended.



- Every driver and operator of a vehicle or an item of plant shall be in possession of a valid permit in respect of the class of vehicle or item of plant he / she is driving or operating.

The Contractor shall provide, erect and maintain sufficient road signs, barricades, fencing and guarding as may be necessary or required by the Employer's Agent or by any act, regulation or statutory authority in order to minimise the danger and inconvenience caused to vehicle and pedestrian traffic. The Contractor by accepting this contract shall be deemed to have indemnified the Employer and the Employer's Agent against any claims, damages and / or costs that may arise in this regard.

### **B1236 ENVIRONMENTAL IMPACT CONTROL**

In addition to aspects of the design which are intended to avoid or reduce environmental impact, and in addition to normal good construction practice expected of the Contractor, the following requirements shall also be observed:

- (a) The Contractor shall comply with the requirements of Part C: Environmental Management Specification contained in section C3.3 Particular Specifications.
- (b) Clearing shall be limited to the road prism and, where applicable, to detours, which shall be sited in consultation with the Employer's Agent and the local communities.
- (c) No littering by construction workers shall be allowed. A refuse control system shall be established for the collection and removal of refuse to the satisfaction of the Employer's Agent.
- (d) Adequate provision shall be made for temporary toilet requirements in construction areas. Use of the veld for this purpose shall not be allowed under any circumstances.
- (e) Streams, rivers and dams shall be protected from direct or indirect spillage of pollutants, such as refuse, garbage, cement, concrete, sewage, chemicals, fuels, oils, aggregate tailings, wash water, organic materials and bituminous products. In the event of spillage, prompt action shall be taken to clear the affected area. Emergency measures in the event of spillage shall be set out and the responsible person shall be made aware of the required action. The construction of temporary and / or permanent dams shall be done with the necessary approvals from the Department of Water Affairs and Forestry and the Department of Environmental Affairs and Tourism.
- (f) Bituminous and / or other hazardous products shall not be spoiled on site and shall only be disposed of at licensed authorised disposal facilities.
- (g) Provision shall be made to prevent excessive erosion and siltation throughout the contract and in particular on adjacent land. Should excessive erosion and / or siltation take place outside the road reserve as a direct result of the Contractor's construction activities, the Contractor shall be responsible for making good the erosion / siltation to the satisfaction of the landowner and the Employer's Agent.
- (h) Invader species of plants shall be controlled.
- (i) Dust and noise pollution shall be restricted to acceptable levels.

No separate payment shall be made for observing these requirements as such payment shall be deemed to be included in the amount tendered for item B13.01(c) (The contractor's general obligations: Time-related obligations). Any avoidable non-compliance with these requirements shall be considered sufficient grounds for withholding payment of part or all of the amounts to be paid for the above item in order to pay for the repairs to any damages.

### **B1237 MEASUREMENT AND PAYMENT**

<b>Item</b>		<b>Unit</b>
<b>B12.01</b>	<b>Services:</b>	
(a)	Protection, relocation, realignment, removal or replacement of services .....	provisional sum

- (b) Handling costs and profit in respect of subitem B12.01(a) above.....percentage (%)

Expenditure under this item shall be made in accordance with clause 6.6 of the General Conditions of Contract 2015.

The tendered percentage is a percentage of the amount of expenditure approved by the Employer's Agent under subitem B12.01(a), and shall include full compensation for the handling costs of the Contractor and the profit in connection with the protection, relocation, realignment, removal or replacement of the relevant services.

**Item** **Unit**

**B12.02 Construction of new survey beacons and protection of existing survey beacons:**

- (a) Provisional sum for new survey beacons to be constructed or for existing survey beacons to be protected during construction..... provisional sum

- (b) Handling costs and profit in respect of subitem B12.02(a) above.....percentage (%)

Expenditure under this item shall be made in accordance with clause 6.6 of the General Conditions of Contract 2015.

The tendered percentage is a percentage of the amount of expenditure approved by the Employer's Agent under subitem B12.02(a), and shall include full compensation for the handling costs of the Contractor and the profit in connection with the construction of new survey beacons or the protection of existing survey beacons.

**Item** **Unit**

**B12.03 Provision of a Community Liaison Committee:**

- (a) Wages, salary, allowances, etc..... provisional sum

Expenditure under this item shall be made in accordance with clause 6.6 of the General Conditions of Contract 2015.

**Item** **Unit**

**B12.04 Provision of a Community Liaison Officer:**

- (a) Wages, salary, allowances, etc..... provisional sum

- (b) Handling costs and profit in respect of subitem B12.03(a) above.....percentage (%)

Expenditure under this item shall be made in accordance with clause 6.6 of the General Conditions of Contract 2015.

The tendered percentage is a percentage of the amount of expenditure approved by the Employer's Agent under subitem B12.03(a), and shall include full compensation for the handling costs of the Contractor and the profit in connection with the provision of a Community Liaison Officer."

**SECTION 1300: CONTRACTOR'S ESTABLISHMENT ON SITE AND GENERAL OBLIGATIONS**

**B1302 GENERAL REQUIREMENTS**

**(c) Legal and contractual requirements and responsibility to the public**

*Add the following new paragraphs to the end of subclause 1302(c):*

"Legislation imposes mutual obligations on the Employer and Contractor in the performance of their duties to society and to the built and natural environment. To assist the Contractor in understanding and assessing his obligations, and thus to make allowances for the cost of compliance with this legislation, Parts C, E, F and G are included in section C3.3 Particular Specifications in the project specifications.

The Contractor's general obligations shall also include the training of temporary labour, the management of labour enhanced work, the application of the Compensation for Occupational Injuries and Diseases Act, 1993, and compliance with the requirements of Part C: Environmental Management Specification, Part E: OHS 1993 Health and Safety Specification, Part F: Requirements of the Expanded Public Works Programme (EPWP) and Part G: Small Contractor Development contained in section C3.3 Particular Specifications.

Part C: Environmental Management Specification contains the environmental management specification for this project. Its provisions regulate the Contractor's construction methods so as to ensure responsible conduct with respect to the environment and responsible treatment of the environment relevant to the project. No separate payment mechanism has been made available for the Contractor to allow for his compliance with the environmental management specification. The Contractor shall therefore include for such costs in the existing pay item B13.01 in section 1300.

Part E: OHS 1993 Health and Safety Specification contains the specifications that regulate the Contractor's construction methods so as to ensure the health and safety of his employees and the public. A new pay item B13.02 is included in section 1300 to allow the Contractor to make separate provision for the cost of health and safety obligations during the construction process.

Part F: Requirements of the Expanded Public Works Programme (EPWP) contains requirements for employment and training in terms of the National Youth Service programme (where applicable – refer to Part F). Various pay items related to these requirements are included in Part F. However, to the extent that any costs relating to the requirements of Part F are not covered by the pay items in that section, the Contractor shall include for such costs in the existing pay item B13.01 in section 1300.

Part G: Small Contractor Development contains provisions that regulate the Contractor's construction processes for compliance with Government's initiatives towards broad-based black economic empowerment. Various pay items related to these requirements are included in Part G. However, to the extent that any costs relating to the requirements of Part G are not covered by the pay items in that section, the Contractor shall include for such costs in the existing pay item B13.01 in section 1300. The Contractor shall note that non-compliance with the provisions of Part G may lead to the imposition of penalties as described in clause G1003(d)."

**B1303 PAYMENT**

*Add the following at the start of clause 1303:*

"All references in clause 1303 to the final value of the work increasing or decreasing by "twenty (20) per cent" in terms of the COLTO Standard Specification shall be read as increasing or decreasing by "fifteen (15) per cent" in terms of the General Conditions of Contract 2015.

Separate provision has been made in the Schedule of Quantities for the pricing of the Contractor's "General Item" obligations with regard to Health and Safety."

*Refer to the second sentence of the fourth last paragraph of clause 1303, page 1300-2 of the COLTO Standard Specifications and delete the words "from the date on which the Contractor has received the letter of acceptance in terms of clause 12 of the general conditions of contract," and replace these words with the following:*

“from the Commencement Date in terms of clause 5.2.1 of the General Conditions of Contract 2015,”.

*Add the following at the end of clause 1303:*

"The amount payable to the Contractor for time-related general obligations arising from extensions of time granted in accordance with Clause 5.12.1 and 5.12.2 of the GCC 2015, shall be calculated as follows:

(i) The Contractor shall apply for the extension of time in terms of the number of days' delay incurred calculated in accordance with clause 5.1 of the GCC 2015.

(ii) The number of days' extension of time calculated in accordance with clause 5.1 of the GCC 2015, finally granted shall then be added to the Due Completion Date of the contract by the Employer's Agent, commencing on the first working day after the day of the original Due Completion Date. Non-working days and special non-working days as defined in the contract data shall not be counted as working days in calculating the extended completion date.

(iii) The number of calendar days extension of time granted from the original completion date to the extended completion date as calculated in (ii) above shall then be calculated, commencing on the first calendar day after the day of the original completion date.

The following formula shall then be used to calculate the number of months extension of time granted:

No. of months extension of time granted

= [(No. of calendar days extension of time granted / 365)] x 12

(iv) The number of months extension of time granted calculated as in (iii) above shall be the number of additional months measured for payment for time-related general obligations under item B13.01(c) and in accordance with clause 5.12.3 as a result of the extensions of time granted.

**Note:** The number of months extension of time granted calculated as in (iii) above shall also be included in the measurement of any other items scheduled under Sections 1300, 1400, 1500 or elsewhere in the Schedule of Quantities that involve the unit of measurement "month" and that were provided on site for the full duration of the extended period. Where such items were provided for a portion of the extended period only, a pro rata payment shall be made, based on the number of calendar days the item was provided on site after the original completion date divided by the number of calendar days as calculated in (iii) above for the extension of time granted."

<b>Item</b>	<b>Unit</b>
<b>B13.01</b>	<b>The contractor's general obligations:</b>

*Add the following before the start of the first paragraph of item 13.01:*

"Subitems B13.01(a), (b) and (c) are "General Items" as defined in clause 1.1.1.21 of GCC 2015."

*After the end of subclause (iii) in the fourth paragraph of item 13.01, add the following new subclauses which further define the contractor's general obligations:*

(iv) Complying with the requirements and conditions of the additional specifications in Part C: Environmental Management Specification.

(v) Complying with the requirements and conditions of the additional specifications in Part F: Requirements of the Expanded Public Works Programme (EPWP) to the extent that any costs relating to the requirements of Part F are not covered by the pay items included in that section.

(vi) Complying with the requirements and conditions of the additional specifications in Part G: Small Contractor Development relating to the Government's broad-based black economic empowerment initiatives to the extent that any costs relating to the requirements of Part G are not covered by the pay items included in that section."

Add the following new payment items at the end of clause 1303:

“Item

Unit

**B13.02 Health and Safety obligations:**

- (a) Fixed obligations for the preparation of risk assessments, safe work procedures, the project Health & Safety file, the Health & Safety plan and any other Health & Safety matters that the Contractor deems necessary lump sum (Sum)
- (b) Fixed obligations for completing and checking the Project Health & Safety file and handing it over to the Employer on completion of the Works lump sum (Sum)
- (c) Time-related obligations for updating and amending the risk assessments, the safe work procedures, the project Health & Safety file and the Health & Safety plan, and for full compliance with all Health & Safety matters during the construction of the Works under the contract month

Payment of the lump sums tendered under subitems B13.02(a) and (b) and the rate per month for subitem B13.02(c) shall, for the three subitems together, include full compensation for all the Contractor's costs in respect of compliance with the OHS Act and Construction Regulations.

Payment of each of the lump sums tendered under subitems B13.02(a) and (b) shall be made in three instalments as specified in the COLTO standard specifications for the payment of the lump sum tendered under subitem 13.01(a).

The tendered rate for subitem B13.02(c) shall be paid as specified in the COLTO standard specifications for the payment of the tendered rate for subitem 13.01(c).

**1. B13.03 Supply, transport to site and erection of the contract signboard**

<u>ITEM</u>	<u>UNIT</u>
B13.03 Supply, transport to site and erection of the contract signboard	
(a) Contract sign boards	No
(b) Information boards	No

The unit of measurement shall be the number of contract signboards erected as instructed by the Employer's Agent.

The tendered rate shall include full compensation for providing and erecting each contract signboard complete (refer to the typical signboard face detail shown in Section C4.2), including for timber poles and fixings, excavation and backfill, and for dismantling and removing the signboard structures and reinstating the signboard area on completion."

The Contractor will be required to erect a signboard displaying the EPWP logo, indicating that this project is part of the EPWP. All costs related to the provision, erection and subsequent removal of the signboard shall be refunded to the Contractor through the provisional sum included in the Schedule of Quantities for this purpose.

**B13.04 Professional Safety Officer (Registered SACPCMP)**

**ITEM**

**UNIT**

B13.04 Professional Safety Officer (Registered SACPCMP)

month

The tendered rate for sub-item B13.02 (d) shall be paid per month to provide a professional safety officer registered (SACPCMP).

**SECTION 1400: HOUSING, OFFICES AND LABORATORIES FOR THE EMPLOYER'S AGENT'S SITE PERSONNEL**

**B1402 OFFICES AND LABORATORIES**

**(a) General**

*Add the following new paragraph at the end of this sub-clause:*

The offices and ablution shall, unless otherwise agreed, be erected in close proximity to the contractor's offices, and the entire area shall be fenced with security fencing and provided with a gate. The contractor shall take all reasonable precautions to prevent unauthorised entry to the Engineer's office and to ensure the general security of the offices.

*Add the following after the last paragraph:*

**(b) Offices**

*Add the following items to the list of equipment under Sub-clause 1403(a):*

(ixx) Provision of floodlights, which are to be controlled by a photocell for security purposes at the offices of the supervisory staff.

(xx) White boards (2 m x 1 m)

(xxi) Microwave (30 litre capacity)

**B1404 SERVICES**

**(a) Water, electricity and gas**

*Add the following:*

"The power supply to the Engineer's office and laboratory shall be regulated by a suitable voltage regulator in order to maintain a constant current and voltage level at all times to prevent damage to the office equipment and related machinery during power surges. Payment for the voltage regulator shall be deemed to be included in the rates tendered for the supply of power. In the event of damage to the office and laboratory equipment and related machinery because of a faulty voltage regulator, the contractor shall be liable for payment of all repair or replacement costs of such damaged items."

**B1406 MEASUREMENT AND PAYMENT**

*Additional payment items to cover the requirements of the project specifications are listed below.*

*Add the following new payment items:*

<u>ITEM</u>		<u>UNIT</u>
B14.03	Office and laboratory fittings, installations and equipment (a) Items measured by number	
	(xx) White Boards (2m x 2m)	No
	(xxi) Microwave oven (30 litres min. capacity)	No
<u>ITEM</u>		<u>UNIT</u>
B14.11	Sundries (a) Provisional sum for providing sundries as requested by the engineer.	Prov Sum

(b) Handling costs and profit in respect of subitem B14.11(a) above %

Expenditure under these items will be made in accordance with the General Conditions of Contract.

The tendered percentage is a percentage of the amount actually spent under Item B14.11(a), which shall include full compensation for the handling costs of the contractor, and the profit in connection with providing sundries as requested by the engineer.



## **SECTION 1500: ACCOMMODATION OF TRAFFIC**

### **B1501 SCOPE**

*Add to Clause 1501 the following:*

The scope of this section shall also include the preparation and submission to the Engineer for approval of traffic management plans. The traffic management plans shall demonstrate how the Contractor intends accommodating and controlling traffic through the site. The plans must incorporate all the requirements of the specifications in respect of the accommodation of traffic, including the traffic control devices and the personnel involved. A traffic safety officer shall be specifically named in the Plan together with 24 hour contact details. Copies of the plans shall be made available to the Engineer, the Employer, Local Authorities, the Police and Emergency Services.

The accommodation of traffic shall generally be undertaken in the following manner:

- (a) Via gravel diversions, where practical in terms of space and the terrain.
- (b) By dealing with traffic under construction where no diversions are possible.
- (c) By diverting traffic along the existing road where the route is being realigned

*Add the following to the end of clause 1501:*

“Throughout the course of the contract the contractor shall ensure that the works do not prevent service owners or the employer’s other contractors from gaining access through the site.

The contractor shall be required to accommodate traffic in the vicinity of the points at which he accesses the site from the existing road network. All movements of the contractor’s plant to and from the existing access road at these intersections shall be strictly controlled by means of appropriate signage, delineators, stop / go facilities and flagmen.”

### **B1502 GENERAL REQUIREMENTS**

- (a) Safety

*Add to Sub-clause 1502(a) the following:*

Information in respect of intersections, accesses, bus stops, traffic volumes, pedestrians etc is given in Part B of these Project Specifications.

- (b) Providing Temporary Deviations

*Add to Sub-clause 1502(b) the following:*

The contractor shall keep the provincial traffic police, the municipal traffic departments and the engineer fully informed with regard to any changes in the normal traffic flow and obtain their approval for these changes.

During the non-working hours, all unnecessary obstructions to the traffic shall be removed and all signs no longer applicable to the situation shall be removed or effectively covered.

It is a condition of this contract that not more than 10 km of deviation should be open to public traffic at any one time, and that not more than three separate deviations should be open at any one time. No additional payments will be made where situations arise that the contractor has deviations cross over the roadway under construction.

- (i) **Traffic Safety Officer**

*Add to Sub-clause 1502(i) the following:*

The Contractor shall submit a CV of the candidate to the Engineer for approval before the Traffic Safety Officer is appointed. The Traffic Safety Officer shall be made available to discuss road safety and traffic accommodation matters whenever required by the Engineer.

*Delete Sub-clause 1502(i), sub-sub-clauses (ii) and (iii) and replace with the following:*

- (ii) Record on neat and dimensioned sketches and submit to the Engineer the position and sign reference number where applicable of each sign, barricade, delineator, cone, amber flicker light, guardrail and permanent or temporary painted road marking feature.

The position of each unit shall be adequately referenced to identifiable permanent features located along the site of the works.

These records shall also show the date and time at which the recorded traffic accommodation features are certified correct by the Traffic Safety Officer, and shall be signed by the Traffic Safety Officer before being submitted to the Engineer.

The records shall be amended whenever changes are made in the field and the revised detailed sketches shall be submitted to the Engineer. This shall include the recording of the position of flagmen and stop/go control men and their associated traffic accommodation equipment wherever they are used.”

- (iii) Personally inspect the position and condition of each traffic accommodation feature on the whole site of works twice each day by 9:30 and by 16:30, to record all irregularities discovered and the remedial action taken, and to sign off as correct and submit to the Engineer such record sheets by 10:00 and by 17:00 each day. The traffic Safety Officer shall keep a duplicate book for this specific purpose.

The Traffic Safety Officer shall also submit to the Engineer by 10:00 each morning, a record of all matters pertinent to site safety and traffic accommodation throughout the site of works the previous day. He shall also record the daily labour returns of flagmen, stop/go and traffic signal control men employed.

The traffic safety officer shall be equipped with a cellular telephone and shall have a vehicle and 2 labourers at his disposal 24 hours a day, including public holidays and the shutdown period as instructed by the engineer. He shall also be directly answerable to the Contractor's Site Agent. The Traffic Safety vehicle shall be a truck with a capacity of 1 ton and shall be equipped with a high visibility rear panel. The traffic Safety Officer shall have a direct line of communication at all times with the police and traffic officers responsible for the area within limits of the Contract.

*Add to Sub-clause 1502(i) the following new sub-sub-clauses:*

- (ix) Ensure that all obstructions, soil and gravel heaps, related to the Contractors activities be removed before nightfall where applicable and as instructed by the Engineer and that the roads are safe for night traffic.

- (x) The Traffic Safety Officer shall, in addition to the duties listed in Clause 1502 (i), also be responsible for removal of broken down vehicles off the roadway and implementing actions requested by the traffic authorities with regard to the work to be carried out, and shall be responsible for the erection and maintenance of all traffic signs necessary for the accommodation of traffic.”

*Add the following new Sub-clauses to Clause 1502:*

**(j) Public traffic**

The contractor must plan and conduct his activities so as to bring about the least possible disruption to the traffic on the road. All halting of traffic will require the prior approval of the engineer and must be pre-arranged with the appropriate traffic authorities. In all dealings with the public the Contractor shall bear in mind the public's right to enjoy the use of the road, and the Employer's desire to interfere as little as possible with this right. At all points of contact with the public, the Contractor shall deal with deliberate courtesy and understanding in any discussions or disputes.

**(a) Failure to comply with provisions**

The failure or refusal of the Contractor to provide barricades or traffic signs at the proper time, or to take the necessary precautions for the safety and convenience of public traffic as specified or instructed by the Engineer, shall be sufficient cause for the suspension of all work under this Contract without any additional compensation to the Contractor until the required accommodation of traffic has been completed to the satisfaction of the Engineer. The above shall be sufficient cause for the Engineer to deduct penalties as follows:

- **A fixed penalty of R5 000,00 per occurrence shall be deducted for each and every occurrence of non-compliance with any of the requirements of Section 1500 of the standard specifications and section B1500 of the Project Specifications.**
- **In addition a time-related penalty of R500,00 per hour over and above the fixed penalty shall be deducted for non-compliance to rectify any defects in the accommodation of traffic within the allowable time after an instruction to this effect has been given by the Engineer. The Engineer's instruction shall state the allowable time, which shall be the time in hours for reinstatement of the defects. Should the Contractor fail to adhere to this instruction, the time-related penalty shall be applied from the time the instruction was given.**
- **Furthermore, failure to comply with the provisions of clause B1502(i) will also result in a pro-rata penalty to be deducted from payment item B15.14 by the engineer.**

The penalties shall be deducted from the payment certificate for the month in which the non-compliance occurs.

**(b) Access to work area**

Construction traffic will only be permitted to enter or leave the work area at points approved by the Engineer and as clearly indicated on the traffic management plans. When any access point is in use, flagmen shall be provided for each such point. At least two flagmen shall be stationed at the access point to control the movement of construction traffic, and to warn public traffic on both lanes of the existing road. It is not the purpose of these flagmen to stop public traffic flow.

**(c) Extension of time for completion**

Accommodation of public traffic on the works or any delays caused thereby, as well as any suspensions due to failure by the Contractor to comply with the provisions for the accommodation of traffic, will not be regarded as special circumstances for an extension of time.

**B1503 TEMPORARY TRAFFIC-CONTROL FACILITIES**

*Replace the first sentence of the first paragraph of clause 1503 with the following:*

"The contractor shall provide, erect and maintain the necessary traffic-control devices, road signs, channelisation devices, barricades, warning devices and road markings (hereinafter referred to as traffic-control facilities) in accordance with these project specifications and as shown on the drawings and in the South African Road Traffic Signs Manual in conjunction with the latest edition of Road Signs Note No.13 - Roadworks, and shall remove them when no longer required.

The contractor shall replace at his own cost any traffic-control facilities that have been damaged, lost or stolen. The contractor shall also remove all bituminous or other foreign material from the traffic-control facilities in order to keep them clean and visible at all times. Traffic-control facilities that can no longer be cleaned effectively shall be replaced with new ones at the cost of the contractor."

*Replace the first sentence of the third paragraph of clause 1503 with the following:*

"The type of construction, spacing and placement of traffic-control facilities shall be in accordance with the latest edition of Road Signs Note No.13 - Roadworks, these project specifications, the drawings and the South African Road Traffic Signs Manual.

The details shown for spacing and placement of traffic-control facilities may, however, be revised at the discretion of the engineer where deemed necessary to accommodate local site geometry and traffic conditions.”

**(a) Traffic-control devices**

*Add the following new paragraph after the end of the second paragraph of subclause 1503(a):*

“The reduction of the road width to a single lane carrying one-way traffic and controlled by “Stop / Go” boards shall be allowed only during daylight hours in clear weather conditions when work is actively taking place on the road, and such reduction of the road width shall always be accompanied by sufficient on-going watering to keep the dust down at all times on any trafficked gravel surfaces in order to maintain good visibility along the deviation. At least two lanes carrying two-way traffic shall be provided at all other times.”

**(b) Road signs and barricades**

*Add the following to the end of subclause 1503(b):*

“The contractor shall be responsible for the protection and maintenance of all signs, and shall at his own cost replace any that have been damaged, lost or stolen.

The temporary road signs required for this contract shall generally be mounted on poles installed in the ground. Where temporary signs such as delineators are mounted on portable supports, the only permitted method of ballasting such sign supports shall consist of durable sandbags filled with sand of adequate mass to prevent the signs from being blown over by wind. The cost of the sandbags shall be included in the tendered rates for the applicable types of temporary road signs.

The traffic-control devices, temporary signs and devices required in the contract are those designated in Road Signs Note No.13 - Roadworks.

The covering of permanent road signs, if applicable, shall be carried out by utilising a hessian bag which shall be pulled over the sign in the form of a hood and fastened to the sign posts using wire ties. Plastic bags or other materials, and fastening by means of adhesive tape, shall not be permitted for this purpose. The cost of covering permanent road signs shall be deemed to be covered by the tendered rates for items B15.01.

No work may proceed on any section where accommodation of traffic is required until such time as the relevant requirements with regard to signposting are met and the written approval of the engineer has been obtained. The contractor shall keep sufficient surplus signs, delineators and barricades on the site to allow for the replacement of damaged or missing items immediately upon discovery, or within three hours of instructions to such effect having been given by the engineer. Delineators shall be of the flexible plastic / rubber reversible variety and not of the rigid metal variety.”

**(c) Channelization devices and barricades**

*Add the following paragraphs at the end of subclause 1503(c):*

“Delineators shall be manufactured from plastic / rubber materials and shall be adequately ballasted with sand bags to prevent the signs from being blown over by wind or wind turbulence from moving traffic.

Traffic cones shall be manufactured from fluorescent orange or red plastic material, and shall be used only at short term lane deviations during daylight hours. All traffic cones used on deviations shall be 750mm high. Lane closures which continue into the night time shall be demarcated by delineators only.

The use of steel drums as channelization devices shall not be allowed on this Contract. Channelization shall be effected by the use of delineators or cones as detailed in Road Signs Note No. 13 - Roadworks.”

**(e) Warning devices**

*Add the following to subclause 1503(e):*

“All construction vehicles and plant used on the works shall be equipped with 200mm diameter rotating amber flashing lights and with "Construction Vehicle" warning signs. All vehicles and plant shall obtain a clearance permit from the engineer before being allowed onto the site.

Rotating lights shall have an amber lens of minimum height of 200mm and shall be mounted to ensure clear visibility from all directions. The lights on construction vehicles shall be switched on as the vehicles decelerate to enter a construction area, while construction vehicles are operating within the accommodation of traffic area, and as the vehicles accelerate to the general speed when entering the road from a construction area. Lights on plant shall operate continuously while the plant is working alongside sections of road open to public traffic.

All LDVs and cars operating on site shall also be equipped with rotating amber flashing lights which shall be placed so as to be clearly visible and shall be operated continuously while the vehicles are manoeuvring in or out of traffic or while the vehicles are travelling alongside or parked alongside roads open to public traffic.

Rotating lights and the "Construction Vehicle" warning signs on the contractor's vehicles and plant shall not be paid for separately but shall be included in the rates covering the use of the vehicles.

The contractor shall apply and maintain to the approval of the engineer such rotating amber lights and warning signs, together with any temporary mounting brackets. Vehicles and plant that do not comply with these requirements shall be removed from the site.”

*Add the following new subclauses to clause 1503:*

**(g) Other signs and facilities**

The engineer may instruct the contractor to provide any other road sign, reflective tape, etc. not measured in the standard pay items. Such other road signs, reflective tape, etc. shall conform to the requirements of the South African Road Traffic Signs Manual and any other specification provided by the engineer.

The Contractor shall inform the general public of the intended road works, construction period and accommodation of traffic proposal through press releases in local and provincial newspapers. Cones shall be manufactured and positioned in accordance with the details specified on the drawings. All traffic cones and road signs shall be kept clean and visible at all times. All bituminous or other foreign material shall be removed by the Contractor, or the dirty traffic cones and road signs shall be replaced with new ones at the cost of the Contractor, as directed by and to the satisfaction of the Engineer.

**(h) High visibility safety vests**

The contractor shall ensure that all his own personnel, excluding those who are permanently office bound, all other construction workers on the site, staff of the engineer and visitors are equipped with high visibility reflective safety vests. High visibility reflective safety vests shall be worn at all times when working on or near to the travelled way. High visibility reflective safety vests shall be kept in good condition and any such safety vests that are, in the opinion of the engineer, ineffective shall be replaced immediately by the contractor.

**B1505 TEMPORARY DRAINAGE WORKS**

*Replace the following:*

“Clauses 40 and 53” with “Clause 6.4 and 6.5”

**B1511 MAINTENANCE OF GRAVEL TEMPORARY DEVIATIONS AND EXISTING GRAVEL ROADS USED AS TEMPORARY DEVIATIONS**

*Add to Clause 1511 the following:*

Where applicable, all references to gravel roads and/or diversions shall also include gravel shoulders used as diversions.

**B1517 MEASUREMENT AND PAYMENT**

*Amend the following payment item:*

<u>ITEM</u>		<u>UNIT</u>
B15.01	Accommodating traffic and maintaining temporary deviations.	km

*Delete the second sentence of the second paragraph.*

The rest of the second paragraph of Payment Item 15.01 shall apply.

*Delete the third paragraph and replace with:*

The tendered rate shall also include for the preparation of traffic management plans and their submission to the Engineer for approval before the commencement of any construction works. The tendered rate shall also include for all costs associated with constructing the road under traffic and for complying with the restricted working.

<u>ITEM</u>		<u>UNIT</u>
B15.03	Temporary traffic-control facilities:	
	(a) Flagmen	man-day

*Add the following:*

- 1) Competent staff must be used for controlling traffic, as their actions can affect the safety of both the road users and road workers.
- 2) Local labour shall be trained during traffic accommodation workshops prior to works being carried out.

*Add the following new payment items:*

<u>ITEM</u>		<u>UNIT</u>
B15.12	Temporary culverts:	
	(a) Provision and laying of temporary and prefabricated culverts complete (1200mm dia. Spigot and Socket, Class 100D on class C bedding)	m
	(b) Eventual removal of prefabricated culverts	m

*Add the following to the end of the first paragraph:*

The tendered rate shall also include for the removal of the temporary detour, including all associated earthworks and the rehabilitation of the river channel. Payment shall be regarded as included in the rates tendered for the applicable items for the above-mentioned work.

<u>ITEM</u>		<u>UNIT</u>
B15.14	Traffic Safety Officer	month

The unit of measurement will be a month worked by the Traffic Safety Officer. The tendered rate shall include full compensation for the provision of a full time traffic safety officer equipped with a dedicated vehicle, cellular telephone, 2 (two) labourers at his disposal 24 hours a day, including public holidays and the shutdown period as instructed by the engineer and all the duties performed by him as specified in Sub-Clause 1502 (i).

---

<u>ITEM</u>		<u>UNIT</u>
B15.15	Penalties:	
	(a) (i) Fixed penalty for noncompliance of traffic safety requirements per occurrence	No
	(b) (ii) Time related penalty for B15.15 (a)(i) above	Hour

A fixed penalty deduction of R 5000,00 per occurrence shall be applied in terms of subitem B15.15 (a)(i) for every occurrence of non-compliance with any of the requirements of Section 1500 of the standard specifications and section B1500 of the project specifications.

In addition to the fixed penalty deduction in item B15.15 (a)(i), a time related penalty deduction of R 500,00 per hour shall be applied in terms of subitem B15.15 (b)(ii) for non-compliance in rectifying any defects in the accommodation of traffic within the allowable time after an instruction to this effect was given by the engineer. The engineer's instruction shall state the allowable time, which shall be the time in hours for reinstatement of the defects. Should the contractor fail to comply with this instruction within the allowable time, the time-related penalty shall be applied from the time the instruction was given.

**SECTION 1600: OVERHAUL**

**B1602 DEFINITIONS**

**(a) Overhaul material**

*Add the following to the end of subclause 1602(a):*

"Overhaul shall not be measured separately for payment for materials obtained from commercial sources, and the rates tendered for such materials shall be fully inclusive of all haul required."

**(b) Overhaul**

*Delete the first two paragraphs of subclause 1602(b) and replace them with the following:*

"Restricted overhaul shall not apply to fill material from cut and borrow and to spoil material from excavations when hauled in excess of a free-haul distance of 0,5 km in respect of haul up to and including 1,0 km, and no measurement and payment for restricted overhaul shall be made under any item in respect of material hauled between or over these distances.

Ordinary overhaul only shall apply in respect of haul in excess of 1,0 km."

*Delete the final paragraph of subclause 1602(b) since restricted overhaul shall not apply to the work required under this contract.*

**(d) Free-haul distance**

*Delete the second sentence of subclause 1602(d) and replace it with the following:*

"This distance shall be 1,0 km in the case of all overhaul materials."

**B1603 MEASUREMENT AND PAYMENT**

*Delete item 16.01 since restricted overhaul shall not apply to the work required under this contract.*

*Refer to the **Note** immediately below the description of the unit of measurement for item 16.02. Delete the first paragraph of this note since restricted overhaul shall not apply to the work required under this contract.*

**ITEM**

**UNIT**

B16.02 Overhaul on material hauled in excess of 1.0 km (ordinary overhaul)

m<sup>3</sup> km

Delete the first paragraph of the first set of notes.



**SECTION 1700: CLEARING AND GRUBBING**

**B1704 MEASUREMENT AND PAYMENT**

*Add to Payment Item 17.01 the following*

<u>ITEM</u>	<u>UNIT</u>
B17.01 Clearing and grubbing	ha

The tendered rate shall also include full compensation for removal of existing fences, pipe culvert inlet and outlet structures and kilometre marker posts as instructed by the engineer. Clearing and grubbing for the construction of camp sites shall not be measured separately. Payment shall be regarded as included in the rates tendered for the applicable items for the above-mentioned work.

Within the road reserves clearing and grubbing will only be measured and paid for where required for road works. All topsoil removed in this process must be stockpiled in heaps not exceeding 1 m height for later use during rehabilitation and landscaping.

A portion of this work shall include for labour intensive construction. The tenderer shall make allowance for the employment of local labour and/or the labour of local subcontractors, supplemented by the contractor's key personnel for the use of labour intensive construction.

Labour intensive construction specific to these activities shall be carried out subsequent to the training of local labour. Local labour shall be trained during workshops prior to works being carried out.

The labour intensive activities shall comprise of the following:

- 1) Bush clearing: Medium to Dense Bush
- 2) Grass clearing: Removal of vegetation to ground surface
- 3) Destumping: Removal of stumps and major roots.
- 4) Grubbing: Root removal to 250 mm depth in soft loamy soil.

**SECTION 2100: DRAINS**

**B2104 SUBSOIL DRAINAGE**

**(a) Materials**

(i) Pipes

*Add to Sub-clause 2104(a)(i) the following:*

Slotted or perforated unplasticised PVC pipes shall be used for subsurface drainage.

(ii) Natural Permeable Material

*Add to Sub-clause 2104(a)(ii) the following:*

The crushed stone shall be coarse graded (19mm nominal size) and shall conform to the following requirements:

Percentage passing through a 26,5mm sieve: 100 %.

Percentage passing through a 19,0mm sieve: 60-85 %.

**B2107 MEASUREMENT AND PAYMENT**

*Add the following new Clause after the last paragraph of item 21.01:*

**ITEM**

**UNIT**

B21.01 Excavation for open drains:

(a) Excavating soft material situated within the following depth ranges below the surface level:

(i) 0 m up to 1,5 m m<sup>3</sup>

(b) Extra over subitem 21.01(a) for excavation in hard material, irrespective of depth m<sup>3</sup>

*Add the following sentence to the end of paragraph two.*

Local labour shall be utilised in the excavation of the soft material to the required lines, levels and grades using hand held tools only up to a depth of 1,5 m.

*Add the following new Clause after the last paragraph of item 21.02:*

**ITEM**

**UNIT**

B21.02 Clearing and shaping existing open drains m<sup>3</sup>

A portion of this work shall include for labour intensive construction. The tenderer shall make allowance for the employment of local labour and/or the labour of local subcontractors, supplemented by the contractor's key personnel for the use of labour intensive construction.

Labour intensive construction specific to these activities shall be carried out subsequent to the training of local labour. Local labour shall be trained during workshops prior to works being carried out.

The labour intensive activities shall comprise of the following:

- a) Excavating the material;
- b) Protecting the existing drainage structures;
- c) Trimming the floors and sides of the open drains and

d) Disposing of material

<b><u>ITEM</u></b>	<b><u>UNIT</u></b>
B21.03 Excavating for subsoil drainage systems:	
(a) Excavating soft material situated within the following depth ranges below the surface level:	
(i) 0 m and up to 1,5 m	m <sup>3</sup>
(ii) Exceeding 1,5 m and up to 3,0 m	m <sup>3</sup>
(b) Extra over subitem 21.03(a) for excavation in hard material irrespective of depth	m <sup>3</sup>

*Add the following sentence to the end of paragraph two.*

Local labour shall be utilised in the excavation of the soft material to the required lines, levels and grades using hand held tools only up to a depth of 1,5 m.

*Add the following new Clause after the last paragraph of item 21.04:*

<b><u>ITEM</u></b>	<b><u>UNIT</u></b>
B21.04 Impermeable backfilling to subsoil drainage systems	m <sup>3</sup>

A portion of this work shall include for labour intensive construction. The tenderer shall make allowance for the employment of local labour and/or the labour of local subcontractors, supplemented by the contractor's key personnel for the use of labour intensive construction.

Labour intensive construction specific to these activities shall be carried out subsequent to the training of local labour. Local labour shall be trained during workshops prior to works being carried out.

The labour intensive activities shall comprise of the following:

- a) Placing and
- b) Compacting the backfill

<b><u>ITEM</u></b>	<b><u>UNIT</u></b>
B21.06 Natural permeable material in subsoil drainage systems (crushed stone):	
(a) Crushed stone obtained from commercial sources (19 mm Nominal size)	m <sup>3</sup>

*Add the following sentence to the end of paragraph two.*

Local labour shall be utilised for the placing of the approved crushed stone obtained from local suppliers (where possible).

*Add the following new Clause after the last paragraph of item 21.12:*

<b><u>ITEM</u></b>	<b><u>UNIT</u></b>
B21.12 Concrete outlet structures, manhole boxes, junction boxes and cleaning eyes for subsoil drainage systems:	m <sup>3</sup>
(a) Outlet structures (As per SD 0501)	No
(b) Manholes boxes (As per SD 0501)	No

(c) Cleaning eyes (As per SD 0501)

No

A portion of this work shall include for labour intensive construction. The tenderer shall make allowance for the employment of local labour and/or the labour of local subcontractors, supplemented by the contractor's key personnel for the use of labour intensive construction.

Labour intensive construction specific to these activities shall be carried out subsequent to the training of local labour. Local labour shall be trained during workshops prior to works being carried out.

The labour intensive activities shall comprise of the following:

- a) Excavation;
- b) Backfilling
- c) Compacting to 90% modified AASHTO density;
- d) Disposing of surplus excavated material
- e) Erecting and removal of framework;
- f) Mixing and transporting concrete and
- g) Placing and curing the concrete

*Add the following new Clause after the last paragraph of item 21.19:*

**ITEM**

**UNIT**

B21.19 Selected backfill material under concrete lined side drains compacted to 93% of modified AASTHO density

m<sup>3</sup>

A portion of this work shall include for labour intensive construction. The tenderer shall make allowance for the employment of local labour and/or the labour of local subcontractors, supplemented by the contractor's key personnel for the use of labour intensive construction.

Labour intensive construction specific to these activities shall be carried out subsequent to the training of local labour. Local labour shall be trained during workshops prior to works being carried out.

The labour intensive activities shall comprise of the following:

- (a) Breaking down, placing and compacting the material to 150mm layers

## **SECTION 2200: PREFABRICATED CULVERTS**

### **B2204 CONSTRUCTION METHODS**

*Add to Clause 2204 the following:*

Generally, prefabricated stormwater drainage pipes and rectangular culverts will be installed using the 'trench method'.

*Add the following:*

"in all cases where soft founding materials is classified as suitable for culvert beddings construction, the in-situ material shall be ripped, moistened and compacted to 90 & to 93% modified aashto density. The depth of preparation and compaction of founding material shall be indicated on drawings as specified by the engineer. Allowance for measurement and payment for this work is made in the bill of quantities under this section"

### **HAND EXCAVATABLE MATERIAL**

Hand excavatable material is material:

- a. granular materials:
  - i. whose consistency when profiled may in terms of table 1 be classified as very loose, loose, medium dense, or dense; or
  - ii. where the material is a gravel having a maximum particle size of 10mm and contains no cobbles or isolated boulders, no more than 15 blows of a dynamic cone penetrometer is required to penetrate 100mm;
- b. cohesive materials:
  - i. whose consistency when profiled may in terms of table 1 be classified as very soft, soft, firm, stiff and stiff / very stiff; or
  - ii. where the material is a gravel having a maximum particle size of 10mm and contains no cobbles or isolated boulders, no more than 8 blows of a dynamic cone penetrometer is required to penetrate 100mm;

Note:

- 1) A boulder is material with a particle size greater than 200mm, a cobble and gravel is material between 60 and 200mm; and
- 2) A dynamic cone penetrometer is an instrument used to measure the in-situ shear resistance of a soil comprising a drop weight of approximately 10 kg which falls through a height of 400mm and drives a cone having a maximum diameter of 20mm (cone angle of 60° with respect to the horizontal) into the material being used.

### **Trench excavation**

All hand excavatable material in trenches having a depth of less than 1,5 metres shall be excavated by hand.

### **Compaction of backfilling to trenches (areas not subject to traffic)**

Backfilling to trenches shall be placed in layers of thickness (before compaction) not exceeding 100mm.

Each layer shall be compacted using hand stampers;

- a) to 90% Mod AASHTO;
- b) such that in excess of 5 blows of a dynamic come penetrometer (DCP) is required to penetrate 100 mm of the backfill, provided that backfill does not comprise more than 10% gravel of size less than 10mm and contains no isolated boulders; or
- c) such that the density of the compacted trench backfill is not less than that of the surrounding undisturbed soil when tested comparatively with a DCP.

### **B2210 LAYING AND BEDDING OF PREFABRICATED CULVERTS**

#### **(f) General**

*Add to Sub-clause 2210(f) the following:*

Pipe culverts have been designed to the positions, lengths and elevations shown on the drawings. However, site conditions may dictate that changes are necessary. Any such changes will be agreed with the Engineer and recorded in writing.

**B2211 BACKFILLING OF PREFABRICATED CULVERTS**

*Add to the fourth paragraph of Clause 2211 the following:*

Where backfilling is done in the upper layers of the road formation, the quality and strength of the backfill material shall at least match that of the surrounding layers.

**B2218 MEASUREMENT AND PAYMENT**

*Amend the following payment items:*

<u>ITEM</u>		<u>UNIT</u>
B22.01	Excavation:	
	(a) Excavating soft material situated within the following depth ranges below the surface level:	
	(i) 0 m up to 1,5 m	m <sup>3</sup>
	(ii) Exceeding 1,5 m and up to 3,0 m	m <sup>3</sup>
	(b) Extra over subitem 22.01(a) for excavation in hard material, irrespective of depth	m <sup>3</sup>

*Add the following sentence to the end of paragraph seven.*

Local labour shall be utilised for the excavation of soft material, only up to a depth of 1,5m, and the disposal of excavated material unsuitable for backfilling.

*Add the following new Clause after the last paragraph of item 22.02:*

<u>ITEM</u>		<u>UNIT</u>
B22.02	Backfilling:	
	(a) Using the excavated material	m <sup>3</sup>

A portion of this work shall include for labour intensive construction. The tenderer shall make allowance for the employment of local labour and/or the labour of local subcontractors, supplemented by the contractor's key personnel for the use of labour intensive construction.

Labour intensive construction specific to these activities shall be carried out subsequent to the training of local labour. Local labour shall be trained during workshops prior to works being carried out.

The labour intensive activities shall comprise of the following:

- a) Backfilling under, alongside and covering of the conduits;
- b) Watering and
- c) Compacting the backfilling materials to the specified density

*Add the following new Clause after the last paragraph of item 22.07:*

<u>ITEM</u>		<u>UNIT</u>
B22.07	Cast in situ concrete and formwork:	
	(a) In inlet and outlet structures, skewed ends, catchpits, manholes, thrust and anchor blocks, excluding formwork but including class U2 surface finish (Class 20/19)	m <sup>3</sup>

- (b) Formwork of concrete under subitem 22.07(c) above (Vertical formwork for F1 surface finish) m<sup>2</sup>

A portion of this work shall include for labour intensive construction. The tenderer shall make allowance for the employment of local labour and/or the labour of local subcontractors, supplemented by the contractor's key personnel for the use of labour intensive construction.

Labour intensive construction specific to these activities shall be carried out subsequent to the training of local labour. Local labour shall be trained during workshops prior to works being carried out.

The labour intensive activities shall comprise of the following:

- a) Erecting and removing the formwork;
- b) Constructing the forms; and
- c) Mixing, transporting, placing and compacting concrete

*Add the following new Clause after the last paragraph of item 22.10:*

<b><u>ITEM</u></b>		<b><u>UNIT</u></b>
B22.10	Steel reinforcement	
	(a) Welded steel fabric	kg

A portion of this work shall include for labour intensive construction. The tenderer shall make allowance for the employment of local labour and/or the labour of local subcontractors, supplemented by the contractor's key personnel for the use of labour intensive construction.

Labour intensive construction specific to these activities shall be carried out subsequent to the training of local labour. Local labour shall be trained during workshops prior to works being carried out.

The labour intensive activities shall comprise of the following:

- a) Cutting, bending;
- b) Welding and Placing and fixing the steel reinforcement

*Add the following new Clause after the last paragraph of item 22.12:*

<b><u>ITEM</u></b>		<b><u>UNIT</u></b>
B22.12	Removing existing concrete:	
	(a) Plain concrete	m <sup>3</sup>
	(b) Reinforced concrete	m <sup>3</sup>

A portion of this work shall include for labour intensive construction. The tenderer shall make allowance for the employment of local labour and/or the labour of local subcontractors, supplemented by the contractor's key personnel for the use of labour intensive construction.

Labour intensive construction specific to these activities shall be carried out subsequent to the training of local labour. Local labour shall be trained during workshops prior to works being carried out.

The labour intensive activities shall comprise of the following:

- a) Demolition and loading and
- b) Transporting and disposing of the products of the demolition

*Add the following new Clause after the last paragraph of item 22.12:*

A portion of this work shall include for labour intensive construction. The tenderer shall make allowance for the employment of local labour and/or the labour of local subcontractors, supplemented by the contractor's key personnel for the use of labour intensive construction.

Labour intensive construction specific to these activities shall be carried out subsequent to the training of local labour.

Local labour shall be trained during workshops prior to works being carried out.

The labour intensive activities shall comprise of the following:

- (a) Cutting straight grooves

*Add the following new Clause after the last paragraph of item 22.17:*

<u>ITEM</u>	<u>UNIT</u>
B22.17 Manholes, catchpits, precast inlet and outlet structures complete:	
(a) Manholes (for grid inlets) – SD 0602/B	
(i) 1,0 m to 1,5 m deep	No
(ii) 1,5 m to 2,0 m deep	No
(iii) 2,0 m to 2,5 m deep	No
(b) Catchpits – SD 0703/A	
(1) Brick Manholes for drainage: constructed on all pipes up to 750mm diam.	
(i) 1,0 m to 1,5m deep: Type S1	No
(ii) 1,5 m to 2,0 m deep: Type S1	No
(2) Brick Manholes for drainage: constructed on 750mm dia. pipes	
(i) 1,0 m to 1,5 m deep	No
(ii) 1,5 m to 2,0 m deep:	No

A portion of this work shall include for labour intensive construction. The tenderer shall make allowance for the employment of local labour and/or the labour of local subcontractors, supplemented by the contractor's key personnel for the use of labour intensive construction.

Labour intensive construction specific to these activities shall be carried out subsequent to the training of local labour. Local labour shall be trained during workshops prior to works being carried out.

The labour intensive activities shall comprise of the following:

- a) Laying of brickwork and
- b) Plastering and benching

*Add the following new Clause after the last paragraph of item 22.18:*

<u>ITEM</u>	<u>UNIT</u>
B22.18 Brickwork:	m <sup>2</sup>
(a) 230 mm thick	

A portion of this work shall include for labour intensive construction. The tenderer shall make allowance for the employment of local labour and/or the labour of local subcontractors, supplemented by the contractor's key personnel for the use of labour intensive construction.

Labour intensive construction specific to these activities shall be carried out subsequent to the training of local labour. Local labour shall be trained during workshops prior to works being carried out.

The labour intensive activities shall comprise of the following:

- (a) Laying of brickwork for headwalls

*Add the following new Clause after the last paragraph of item 22.20:*



**ITEM**

**UNIT**

B22.20 Benching:

m<sup>2</sup>

A portion of this work shall include for labour intensive construction. The tenderer shall make allowance for the employment of local labour and/or the labour of local subcontractors, supplemented by the contractor's key personnel for the use of labour intensive construction.

Labour intensive construction specific to these activities shall be carried out subsequent to the training of local labour. Local labour shall be trained during workshops prior to works being carried out.

The labour intensive activities shall comprise of the following:

- (a) Placing the concrete benching

**SECTION 2300: CONCRETE KERBING, CONCRETE CHANNELLING, CHUTES AND DOWNPIPES, AND CONCRETE LININGS FOR OPEN DRAINS**

**B2304 CONSTRUCTION**

**(b) Prefabricated concrete kerbing and channelling**

*Add to Sub-clause 2304(b) the following:*

Kerbing of radius 1m and less shall be cast in situ in accordance with sub-clause 2304(e) and as shown on the drawings.

All precast kerbs shall be provided with continuous in-situ concrete backing (haunching), the cost of which shall be included in the tendered rate.

Dimensions of the triangular-shaped (in cross-section) haunching shall be calculated as follows:

If the difference in levels between the top of the kerb and the sub-base on which the kerb is laid is (h), then the height of the haunch is  $2/3h$  and the width of the haunch is h.

*Add the following new Sub-clauses to Clause 2304:*

**(l) Shrinkage joints for cast in-situ concrete work.**

Unless shown otherwise on the drawings, cast in situ channels shall be provided with shrinkage joints spaced a maximum of 2m apart. Shrinkage joints shall be constructed so that shrinkage cracks are generated at the joints. Sections of channel which have cracked between shrinkage joints shall be removed and replaced by the contractor at his own cost.

**(m) Formwork and finish**

All visible edges of cast in-situ channels shall be rounded with a rounding tool.

**B2307 MEASUREMENT AND PAYMENT**

*Add the following new Clause after the last paragraph of item 23.05:*

<b><u>ITEM</u></b>		<b><u>UNIT</u></b>
B23.05	Inlet, outlet, transition and similar structures (typical designs):	
	(a) 500mm wide combined precast kerb to SABS 927 (Figure 6) and cast in situ channel (Refer to SD 0701/A)	m
	(b) Pipe to open chute including splash walls with 1m transition channels and erosion protection as shown in SD 0704	No
	(c) 1000 V-Drain Outlet chute including 5m transition, 2m straight channel and stone pitching erosion protection (As shown on Drawing SD 0603/A and SD 0603/2)	No

A portion of this work shall include for labour intensive construction. The tenderer shall make allowance for the employment of local labour and/or the labour of local subcontractors, supplemented by the contractor's key personnel for the use of labour intensive construction.

Labour intensive construction specific to these activities shall be carried out subsequent to the training of local labour. Local labour shall be trained during workshops prior to works being carried out.

The labour intensive activities shall comprise of the following:

- a) Placing formwork;
- b) Excavating, trimming and backfilling; and

c) Mixing and placing concrete

*Add the following new Clause after the last paragraph of item 23.07:*

**ITEM**

**UNIT**

B23.07 Trimming of excavations for concrete-lined open drains:

(a) In soft material m<sup>2</sup>

A portion of this work shall include for labour intensive construction. The tenderer shall make allowance for the employment of local labour and/or the labour of local subcontractors, supplemented by the contractor's key personnel for the use of labour intensive construction.

Labour intensive construction specific to these activities shall be carried out subsequent to the training of local labour. Local labour shall be trained during workshops prior to works being carried out.

The labour intensive activities shall comprise of the following:

(a) Preparing the areas for placing concrete

*Add the following new Clause after the last paragraph of item 23.08:*

**ITEM**

**UNIT**

B23.08 Concrete lining for open drains:

(a) Cast in situ concrete lining (Class 20/19 for open drains) m<sup>3</sup>

(b) Class U2 surface finish to cast in situ concrete (Open Drains) m<sup>2</sup>

A portion of this work shall include for labour intensive construction. The tenderer shall make allowance for the employment of local labour and/or the labour of local subcontractors, supplemented by the contractor's key personnel for the use of labour intensive construction.

Labour intensive construction specific to these activities shall be carried out subsequent to the training of local labour. Local labour shall be trained during workshops prior to works being carried out.

The labour intensive activities shall comprise of the following:

- a) Erecting and removing the formwork;
- b) Constructing the forms; and
- c) Mixing, transporting, placing and compacting concrete

*Add the following new Clause after the last paragraph of item 23.08:*

A portion of this work shall include for labour intensive construction. The tenderer shall make allowance for the employment of local labour and/or the labour of local subcontractors, supplemented by the contractor's key personnel for the use of labour intensive construction.

Labour intensive construction specific to these activities shall be carried out subsequent to the training of local labour. Local labour shall be trained during workshops prior to works being carried out.

The labour intensive activities shall comprise of the following:

- a) Erecting and removing the formwork;
- b) Constructing the forms; and
- c) Mixing, transporting, placing and compacting concrete

*Add the following new Clause after the last paragraph of item 23.09:*

<b><u>ITEM</u></b>		<b><u>UNIT</u></b>
B23.09	Formwork to cast in situ concrete lining for open drains (class F2 surface finish):	
	(a) To sides with formwork on the internal face only	m <sup>2</sup>
	(b) To ends of slabs	m <sup>2</sup>

A portion of this work shall include for labour intensive construction. The tenderer shall make allowance for the employment of local labour and/or the labour of local subcontractors, supplemented by the contractor's key personnel for the use of labour intensive construction.

Labour intensive construction specific to these activities shall be carried out subsequent to the training of local labour. Local labour shall be trained during workshops prior to works being carried out.

The labour intensive activities shall comprise of the following:

- a) Erecting and removing the formwork;
- b) Constructing the forms; and
- c) Mixing, transporting, placing and compacting concrete

*Add the following new Clause after the last paragraph of item 23.10:*

<b><u>ITEM</u></b>		<b><u>UNIT</u></b>
B23.10	Sealed joints in concrete linings of open drains(Polysulphide sealant):	m

A portion of this work shall include for labour intensive construction. The tenderer shall make allowance for the employment of local labour and/or the labour of local subcontractors, supplemented by the contractor's key personnel for the use of labour intensive construction.

Labour intensive construction specific to these activities shall be carried out subsequent to the training of local labour. Local labour shall be trained during workshops prior to works being carried out.

The labour intensive activities shall comprise of the following:

- (a) Sealing the joints

*Add the following new Clause after the last paragraph of item 23.12:*

<b><u>ITEM</u></b>		<b><u>UNIT</u></b>
B23.12	Steel reinforcement:	
	(a) High-tensile steel bars	t
	(b) Welded steel fabric	kg

A portion of this work shall include for labour intensive construction. The tenderer shall make allowance for the employment of local labour and/or the labour of local subcontractors, supplemented by the contractor's key personnel for the use of labour intensive construction.

Labour intensive construction specific to these activities shall be carried out subsequent to the training of local labour. Local labour shall be trained during workshops prior to works being carried out.

The labour intensive activities shall comprise of the following:

- a) Cutting, bending;
- b) Welding and
- c) Placing and fixing the steel reinforcement

**SECTION 3200: SELECTION, STOCKPILING AND BREAKING DOWN THE MATERIAL FROM BORROW PITS, CUTTING AND EXISTING PAVEMENT LAYERS, AND PLACING AND COMPACTING THE GRAVEL LAYERS**

**B3204 BREAKING DOWN THE MATERIAL**

*Replace the following in subclause (b) (iii):*

"Clauses 40 and 53" with Clause 6.4".

**SECTION 3300: MASS EARTHWORKS**

**B3301 SCOPE**

*Add to Clause 3301 the following:*

The Contractor shall note the restricted nature of the earthworks in general, and where the widening of existing cuts and fills are required in particular. No extra over rates for widening of cuts, widening of fills or for working in restricted areas shall be applicable to this Contract.

**B3303 CLASSIFICATION OF CUT AND BORROW**

**(a) Classes of excavation**

*Add to Sub-clause 3303(a) the following:*

Cut material for fills will, apart from natural in-situ material, also consist of existing fill and pavement layers from the existing road. Excavation from existing fill and pavement layers varies in depth, but no distinction is made between this excavation and excavation in other materials, except for classification as soft, intermediate and hard materials.

Payment items 33.14 and 33.15 will not apply on this Contract.

**B3306 CUT AND BORROW**

**(a) Dimensions of Cuts**

*Delete the third paragraph from Clause 3306(a), apart from the first sentence thereof.*

*Add the following:*

Cut and borrow to fill will be measured under Item 33.01. The Contractor shall take note of the nature of the earthworks alongside the existing road. No extra over payments will be made in respect of the nature of the site or due to the dimensions of a particular cutting.

**B3312 MEASUREMENT AND PAYMENT**

**General directions**

*Delete Note (3) Work in Restricted Areas and replace with the following:*

On this Contract, no extra over payment will be made due to the nature of the site or the size of the work area available. All costs associated with carrying out the works are deemed to be included in the tendered rates for the items in the Schedule of Quantities.

*Amend the payment items under Clause 3312 as follows:*

**B33.01** In the description of Item 33.01, delete "free-haul up to 0.5 km" and replace with "free-haul up to 1.0 km."

In the fifth paragraph, referring to the tendered rates, delete the words "free-haul distance of 0.5 km" and replace with "free-haul distance of 1.0 km."

Also in the fifth paragraph, after the words "the cutting of benches" insert the words "including benches in existing fill slopes to be widened."

**B33.04** In the description of Item 33.04, delete "free-haul up to 0.5 km" and replace with "free-haul up to 1.0 km."

In the fourth paragraph delete "free-haul distance of 0.5 km" and replace with "free-haul distance of 1.0 km."

**B33.07** Ditto above.

**SECTION 3400: PAVEMENT LAYERS OF GRAVEL MATERIAL**

**B3402 MATERIALS**

**(a) General**

*Add to Clause 3402(a) the following:*

The pavement for the road shall consist of:

- Subbase 200mm G5/G6 material, from commercial
- Upper selected 150mm G7 material, from road prism/stockpile/borrow/ from commercial
- Lower selected 150mm G9 material, from road prism /stockpile/borrow

All layers shall comply with the requirements of Tables 3402/1, 3402/2, 3402/4 and 3402/5 of the Standard Specification. The requirements of Section 3500: Stabilization shall also apply to the relevant layers.

**(b) Compaction Requirements**

*Add to Clause 3402(b) the following:*

The compaction requirements of the pavement layers shall be:

- Subbase 97% of modified AASHTO density
- Upper selected 95% of modified AASHTO density
- Lower selected 93% of modified AASHTO density

**B3406 QUALITY OF MATERIALS AND WORKMANSHIP**

*Add to Clause 3406 the following:*

Test results and re-measurements shall be assessed in accordance with the provisions of Section 8200: Quality Control (Scheme 1), Judgement Plan B of the Standard Specifications, as amended in these project specifications.

**B3407 MEASUREMENT AND PAYMENT**

Delete the note at the start of the measurement and payment clause dealing with work in restricted areas. On this Contract, no extra over payment will be made due to the nature of the site or the size of the work area available. All costs associated with carrying out the works are deemed to be included in the tendered rates for the items in the Schedule of Quantities.

*Add the following new payment item:*

**ITEM UNIT**

B33.14 Pavement layers constructed from gravel obtained from commercial sources:

(a) Gravel selected layer compacted to:

(i) 95% of modified AASHTO density (150mm G7-Upper selected subgrade) m<sup>3</sup>

(b) Gravel subbase (chemically stabilized material) compacted to:

(i) 97% of modified AASHTO density (200mm G5/G6) m<sup>3</sup>

The tendered rate shall include full compensation for procuring, breaking down, placing and compacting the material, including transporting the material and its removal, disposal and transporting for a distance of 1km and up to 5% of volume of oversize material and the protection and maintenance of the layer and the conducting of tests, all as specified. Overhaul shall not be measured separately for payment of materials obtained from commercial sources, and the rates tendered for such materials shall be fully inclusive of all haul required. Special reference is made to clause B1156 "Commercial Source".



## **SECTION 3500: STABILISATION**

### **B3502 MATERIALS**

#### **(a) Chemical stabilizing agents**

*Delete sub-clauses (ii) Ordinary Portland cement and (iii) Portland blast-furnace cement and replace with the following:*

"Cement shall comply with the relevant requirements of SANS 50197-1:2000. The use of strength classes greater than 32,5 shall not be permitted."

### **B3503 CHEMICAL STABILIZATION**

#### **(i) Construction limitations**

*Add to Sub-clause 3503(i) the following:*

Cement stabilization shall not be carried out during falling temperatures when the ambient air temperature falls below 7°C or during rising temperatures when the ambient temperature is below 3°C.

The surface temperature of a compacted stabilized layer shall not be allowed to fall below 1°C during the first three (3) days after stabilization. The Contractor shall be responsible for taking all measures necessary in this regard and shall especially refrain from stabilizing when such night temperatures are probable.

All stabilized layers which have been damaged by frost or by the formation of ice in the layer shall be removed and replaced by the Contractor at his expense unless agreed otherwise by the Engineer. The Contractor shall make due allowance for these requirements in his construction programme, and no claims in this regard will be considered.

### **B3509 QUALITY OF MATERIALS AND WORKMANSHIP**

*Add to Clause 3509 the following:*

Test results and re-measurements shall be assessed in accordance with the provisions of Section 8200: Quality Control (Scheme 1), Judgement Plan B of the standard specifications, as amended in these project specifications.

The Contractor shall advise the Engineer at least 24 hours in advance of any stabilization work to enable him to organise and conduct his own control tests.

Where the stabilising agent is to be spread by hand, the pockets of stabilising agent shall be placed on the layer at regular intervals. However, spreading shall not be carried out before the engineer is satisfied that the correct quantity of stabilising agent can be spread.

Stabilised layers shall be covered for curing within 24 hours, as specified. If the stabilised layer is found to have failed, the cover material shall be removed and the layer rectified if instructed by the engineer. No additional payment shall be made for such removal and remedial work.

### **B3510 MEASUREMENT AND PAYMENT**

Delete the note at the start of the measurement and payment clause dealing with work in restricted areas. On this Contract, no extra over payment will be made due to the nature of the site or the size of the work area available. All costs associated with carrying out the works are deemed to be included in the tendered rates for the items in the Bill of Quantities.

*Add the following note to this payment item:*

<b><u>ITEM</u></b>		<b><u>UNIT</u></b>
B35.02	Chemical stabilizing agent:	
	(i) Road Lime	t
	(ii) Ordinary Portland Cement (SANS 50197-1:2000)	t

The notation used for Portland cement and Portland blast-furnace cement corresponds with the notation specified in SANS 50197-1:2000.

*Add the following new Clause after the last paragraph of item 35.02:*

A portion of this work shall include for labour intensive construction. The tenderer shall make allowance for the employment of local labour and/or the labour of local subcontractors, supplemented by the contractor's key personnel for the use of labour intensive construction.

Labour intensive construction specific to these activities shall be carried out subsequent to the training of local labour. Local labour shall be trained during workshops prior to works being carried out.

The labour intensive activities shall comprise of the following:

- a) Placing pockets of the stabilising agent at regular intervals; and
- b) Spreading by hand, under supervision.

**SECTION 3600: CRUSHED STONE BASE**

**B3607 QUALITY OF MATERIALS AND WORKMANSHIP**

*Delete the second paragraph and add the following:*

Test results and re-measurements shall be assessed in accordance with the provisions of Section 8200: Quality Control (Scheme 1) of the standard specifications, as amended in these project specifications.

**B3608 MEASUREMENT AND PAYMENT**

*Amend the following payment item as follows:*

<u>ITEM</u>		<u>UNIT</u>
B36.01	Crushed-stone base:	
	(a) Constructed from type G2 material obtained from commercial sources and compacted to 102% of modified AASHTO density (150mm thickness) 37.5 mm nominal maximum size stone.	m <sup>3</sup>

**SECTION 3800: BREAKING UP EXISTING PAVEMENT LAYERS**

**B3807 MEASUREMENT AND PAYMENT**

*Add the following payment item:*

<b><u>ITEM</u></b>	<b><u>UNIT</u></b>
B38.16 Sweeping of the milled areas	m <sup>2</sup>

The unit of measurement shall be square metres. The rate tendered shall include for the removal of all loose material within the milled area to create a clean surface for the application of tack.

**SECTION 4100: PRIME COAT**  
**B4102 MATERIALS**

**(a) Priming Material**

Add to the words “, such as MSP 1 or similar,” to the last of the listed priming materials, that is inverted bitumen emulsion.

“Unless otherwise directed, MC 30 cut-back bitumen or an invert bitumen emulsion manufactured from 70/100 penetration grade bitumen such as MSP/1 or similar, shall be used for priming. If the cut-back bitumen prime does not penetrate adequately, between 5% and 10% by volume of power of paraffin may be added to and mixed with the cut-back bitumen by sucking it into the binder distributor and then using the circulating system to achieve mixing.”

**(b) Aggregate for blinding**

*Add the following sentence:*

“Blinding of the primed surface with aggregate shall only be permitted to facilitate vehicular access to adjoining properties”

**B4104 WEATHER AND OTHER LIMITATIONS**

*Delete adverse condition (g) of Clause 4104 and replace with the following:*

**(g) Priming will only be permitted when the moisture content of the top 50mm of the subbase layer is less than 3% as determined by TMH1 Method 10(b).**

**B4106 APPLICATION OF THE PRIME COAT**

*Add the following to subclause (c)*

The nominal application rate of the prime shall be 0,7l/m<sup>2</sup>. Unless directed otherwise by the engineer or indicated on the drawings, the width of the primed surface shall be 150mm wider than the edges of the surfacing on each side.

*Add the following sub-clause:*

“(j) Application in areas treated by reworking and construction of a new base shall be primed using a mechanical distributor complying with sub-clause 4103(a). The edges of the previously constructed or existing surfacing shall be adequately protected by approved means to ensure that an overlap of prime not exceeding 50mm is sprayed onto the previously constructed or existing surfacing.”

**B4107 MAINTENANCE AND OPENING TO TRAFFIC**

*Delete this entire clause and replace with the following:*

“Primed layers shall not be opened to traffic prior to the construction of the asphalt wearing course.”

**B4108 TOLERANCES**

*Replace the first paragraph with the following:*

“The actual spray rates measured at spraying temperature shall not deviate by more than 8.0% from that ordered by the engineer. The engineer may, at his discretion, conditionally accept application rates falling outside this tolerance at reduced payment in accordance with Table B4108/1.

**Table B4108/1: Payment Reduction Factors for Conditionally Accepted Prime Coat**

<b>Deviation specified spray rate at spraying temperature. (%)</b>	<b>Payment reduction factor of tendered rate.</b>
±8,0	1.00
±9,0	0.97
±10,0	0.95
±11,0	0.90
±12,0	0.85
±13,0	0.80

Any deviation outside these limits shall not be paid for, however, the engineer shall have the right to instruct the contractor to make up any deficiency, or blind excessive prime without additional payment. Where so instructed, the material for blinding shall consist of approved, but shall consist of screened 4,75mm nominal single size aggregate. The use of crusher dust for blinding shall not be permitted. If under-spraying occurs, and it is accepted by the engineer, only the actual quantities applied shall be paid for.”

**B4109 TESTING**

*Add the following:*

No payment shall be made if this condition is not adhered to. The contractor shall, at his cost, provide to the engineer’s representative samples of every batch of prime delivered to site.

## **SECTION 4200: ASPHALT BASE AND SURFACING**

### **B4205 GENERAL LIMITATIONS AND REQUIREMENTS AND THE STOCKPILING OF MIXED MATERIAL**

#### **(b) Moisture**

*Add the following at the end of the second last paragraph after "engineer":*

*"even if the underlying layer has been previously primed."*

#### **(c) Surface Requirements**

##### **(iii) Tack Coat**

*Add the following new paragraph:*

"Hand spraying shall only be permitted on areas approved by the engineer. The binder distributor shall be capable to apply the binder evenly over the full area. The equipment shall comply with clause 4103. Tack coat shall be applied to all transverse and longitudinal joints by hand utilizing a paint brush." Tack coat shall be uniformly applied to all transverse and longitudinal joint faces by hand utilising a paint brush."

The tack coat shall be a spray grade 60% cationic or anionic emulsion conforming to SANS 548 OR 309 respectively

### **B4206 PRODUCING AND TRANSPORTING THE MIXTURE**

#### **(b) Production of the mixture**

##### **(ii) Using drum-type mixer plants:**

*Add the following:*

"The contractor shall ensure that sufficient cold-feed bins are installed to accommodate each individual aggregate fraction, including the filler. Pre-blending of aggregate fractions shall not be permitted."

#### **(c) Transporting the mixture**

*Add the following paragraph:*

"Special precautions shall be taken by the contractor to ensure that the temperature of the total mass of asphalt does not decrease by more than 10°C from point of despatch to the point where it is to be paved. The use of the thermal blankets shall be obligatory in instances of cold weather and where the haul time is in excess of 30 minutes." The contractor shall ensure that trucks used to haul asphalt are not overloaded and the legal axle loads are not exceeded. Before any asphalt can be transported, the contractor must provide the engineer with the certified carrying capacity of each truck intended for the purpose of transporting the mix. The contractor shall provide the engineer with a weigh bridge ticket before discharging into the paver hopper.

Any truck that is over loaded shall not be allowed to discharge its load and shall return to the depot/batching plant for adjustment of the load. In addition a penalty shall be applied for the overload."

*Add the following sub-clause:*

#### **(f) Approval of asphalt mixes**

Before any asphalt is placed on the road, the engineer shall approve the mix design. The approval process shall be as follows:

##### **(a) Laboratory mix design**

The contractor shall prepare and submit a laboratory design mix together with test results at four different bitumen contents on the prescribed form D3 of TMH 10. In addition, the proposed asphalt mixture shall be subjected to gyratory testing. All the expenses in preparing and submitting the laboratory design mix shall be to the contractor's cost.

The proposed design, as well as samples of all aggregates and bitumen intended for use, shall be submitted to the engineer for check testing at least six weeks prior to the intended date of commencement with any asphalt production.

**(ii) Plant Mix Design**

After approval is obtained for the laboratory design mix, a plant mix at varying binder contents of approximately 5 to 10 tons each shall be produced. The purpose of the plant mix is for the contractor to prove that the laboratory design mix can be produced successfully and that the plant is accurately calibrated. The engineer shall conduct the necessary testing on the plant mix, which may include "wheel tracking" or other specialised testing, as may be ordered by the engineer, to further evaluate the mix. The plant mix shall not be placed on the road. During the production of the plant mix, the engineer shall be afforded the opportunity to inspect the asphalt plant.

**(iii) Trial Section**

After the plant mix is approved, permission shall be given for laying a trial section at varying binder contents in accordance with the requirements of section 4211 of the specifications. The engineer may require that the mix be further assessed by means of CSIR Wheel Tracking or MMLS testing, the cost of which will be borne by the Employer. Provision is made for payment for the first approved section only including the cost of the specialized testing. Mass production of asphalt shall only commence after approval of the trial section, which should be given within a maximum of ten days.

The engineer may instruct the contractor at any time to halt his paving process and to review the whole or part of the above process should a change of aggregate properties occur, the specified asphalt requirements not being met and/or a consistent asphalt mixture not be produced."

**The specification for the Continuously Graded Medium asphalt base is as follows:**

1. The surfacing shall consist of 13.2mm Continuously Graded Medium Asphalt with a 35/50 pen binder.
2. The nominal binder content shall be 5,5%.
3. The asphalt mixing temperature shall be between 145°C and 170°C.
4. The approved target grading shall comply with Table 4202/11.
5. ITS shall be between above 800.
6. The Marshall voids (75 blows/side) shall be between 3% and 6%.
7. VMA shall be more than 14%.
8. The modified Lottmanns (TSR) > 0,8.
9. MMLS 3 Rutting <2.5mm. Test to be wet at 100k axels, 2400 repetitions per hour, 50°C, 800 kPa tyre pressure, 2.9KN wheel load, briquette thickness 60mm, sample compaction Gyratory.
10. Air permeability at 7% voids shall be less than  $1 \times 10^{-8}$ .
11. Minimum voids after 300 gyrations with the gyratory compactor shall be > 2,0%.
12. The binder film thickness shall be between 5,5 and 8,5 microns.



**Table 4202/11**

SIEVE SIZE (mm)	CONTINUOUSLY GRADED MEDIUM ASPHALT SURFACING	
	MIN	MAX
26.5		
19		
13.2	100	100
9.5	82	100
6.7		
4.75	54	75
2.36	35	50
1.18	27	42
0.6	18	32
0.3	11	23
0.15	7	16
0.075	4	10
Aggregate	93.5%	
Binder Content	5.5%	
Modified Binder	35/50 Pen Bitumen	
Active Filler	1.0% Hydrated Lime	

**B4208 JOINTS**

*Add the following to this clause:*

The position of the longitudinal construction joints shall be such that they do not fall on the wheel paths or on shoulder line markings where the width of the shoulder is less than 2,0m.

Where the difference in level between the new work and the existing road surface exceeds 25mm and public traffic is to use the partially surfaced road, joints shall be treated as follows:

Transverse steps at the end of a day's work shall be tapered off at a slope of 1 vertical to 20 horizontal (1:20) to tie in with the existing surface. The tapered section shall be removed before surfacing is recommenced and a joint formed in accordance with clause 4208 of the specification.

Longitudinal joints exposed to traffic shall be provided with a taper of compacted asphalt material over the full length of the exposed joint. The width of the taper shall be at least 5 times the difference in level between the old and new work.

All costs involved in the provision and removal of these temporary ramps shall be deemed to have been included in the rates tendered for the relevant asphalt pay item.

**B4210 COMPACTION**

*Add the following:*

No roller sensitive asphalt mixes will be allowed on this contract. The asphalt will be classified as roller sensitive if any movement takes place under a steel wheel roller of mass 9t when the temperature of the asphalt layer on the road has dropped to below 110°C. Vibration rollers will not be permitted for the compaction of asphalt layers.

## B4214 QUALITY OF MATERIAL AND WORKMANSHIP

### (b) Coring of asphalt layers

*Add the following:*

“A suitable coring machine shall be available on a daily basis when asphalt paving is taking place. Cores shall only be drilled, when the road temperature is 20°C or less. Core holes shall be filled with hot mix asphalt and compacted, all within 24 hours of the core being drilled. Coring shall be carried out within 48 hours after the paving has been completed and supplied to the engineer. The test results of cores shall be submitted to the engineer within 24 hours after coring.”

### (c) Routine inspection and tests

*Add the following paragraphs:*

“The contractor shall keep accurate records of:

- (i) The position where every truckload of asphalt is paved (chainage, lane, time and date).
- (ii) The temperatures of the asphalt in the trucks both at the mixing plant and at the paving equipment immediately prior to discharging the load.
- (iii) The truck and load number from which control samples are taken. All samples taken shall be appropriately numbered.

Test results and measurements will be assessed in accordance with the provisions of Section 8200: Quality Control (Scheme1) Judgement Plan B.”

*Add the following sub-clause:*

### (d) Special tests

n-Heptane-Xylene Equivalent (Spot test) (AASHTO-T102)

If the engineer suspects that bitumen or asphalt has been overheated, he may order that the bitumen, or the bitumen recovered from the asphalt, be subjected to the Spot Test. Recovery of binder for use in the Spot Test shall be carried out according to an approved method.

Any bitumen having an n-Heptane-Xylene equivalent in excess of 36, or in excess of the manufacturers test result on the dispatched stock, shall be considered to have been overheated and shall be deemed to be rejected unless proven otherwise.”

## B4215 MEASUREMENT AND PAYMENT

*Add the following note to this payment item:*

<u>ITEM</u>		<u>UNIT</u>
B42.07	Trial sections	m <sup>2</sup>

The tendered rate shall include for approximately 100 tonnes of asphalt to be laid for the trial section. The asphalt paved for the trial section will remain part of the permanent works upon approval. Any remedial work (milling out and relaying new asphalt) in case of failure of the trial section shall be to the contractor's account.

The rate shall include two days standing time while the testing and approval of the trial section is done.

*Amend the following payment item:*

<u>ITEM</u>		<u>UNIT</u>
B42.08	100 mm cores in asphalt paving	No

Add the following to the first sentence of the first paragraph of item 42.08 after the word “drilled:”  
“(irrespective of the depth of the core)”

*Add the following new pay item at the end of clause 4215:*

<b><u>ITEM</u></b>		<b><u>UNIT</u></b>
B42.21	Penalty deduction for overloading (refer to item B42.21 in clause B4215 of the project specifications for the calculation of the tendered rate in each case):	
	(a) Penalty deduction with respect to item 42.02	t

The unit of measurement for the calculation of the penalty deduction shall be the ton of asphalt mix transported in excess of the legal load.

The magnitude of the tendered per ton penalty rate applied shall be calculated as twice the contractor’s tendered rate for placing the asphalt surfacing mix under item 42.02 (duly converted to a “per ton” rate), or under item 42.09 per ton, multiplied by minus one:

Rate tendered for subitem B42.21(a) per ton = [(2 x rate tendered per m<sup>2</sup> for item 42.02 (duly converted to a “per ton” rate)) x (-1)]

**SECTION 5200: GABIONS**

**B5202 MATERIALS**

**(f) Filter fabric below the gabions**

*Add the following at the end of subclause 5202(f):*

"In the case of the filter fabric used to line the earth faces of the gabion mattresses at the box culvert inlet/outlet, the following properties shall apply:

Penetration load (minimum)	3500 Newton
Puncture resistance (maximum)	15 mm
Water percolation (minimum)	20 litre / m <sup>2</sup> / sec"

**B5205 MEASUREMENT AND PAYMENT**

*Add the following new Clause after the last paragraph of item 52.03:*

<u>ITEM</u>		<u>UNIT</u>
B52.03	Gabions:	
	(a) Galvanized gabion boxes, hexagonally woven mesh, 80mm x 100mm, 2.7mm dia. with additional PVC coating, as follows:	
	(i) 1.0 m x 1.0 m x 1.0 m	m <sup>3</sup>
	(b) Galvanized gabion mattresses, hexagonally woven mesh, 80mm x 100mm, 2.7mm dia. with 1.0m diaphragm spacing:	
	(i) 2.0m wide by 0.3m high by 6.0m long	m <sup>3</sup>

A portion of this work shall include for labour intensive construction. The tenderer shall make allowance for the employment of local labour and/or the labour of local subcontractors, supplemented by the contractor's key personnel for the use of labour intensive construction.

Labour intensive construction specific to these activities shall be carried out subsequent to the training of local labour. Local labour shall be trained during workshops prior to works being carried out.

The labour intensive activities shall comprise of the following:

- a) Tying and connecting wires;
- b) Loading, transporting and off-loading; and
- c) Assembling and filling of the cages

Add the following new Clause after the last paragraph of item 52.04:

<b><u>ITEM</u></b>		<b><u>UNIT</u></b>
B52.04	Filter fabric	
	(a) Grade B	m <sup>2</sup>

A portion of this work shall include for labour intensive construction. The tenderer shall make allowance for the employment of local labour and/or the labour of local subcontractors, supplemented by the contractor's key personnel for the use of labour intensive construction.

Labour intensive construction specific to these activities shall be carried out subsequent to the training of local labour. Local labour shall be trained during workshops prior to works being carried out.

The labour intensive activities shall comprise of the following:

- a) Cutting; and
- b) Placing, joining, overlapping, and securing the material in position

## **SECTION 5400: GUARDRAILS**

### **B5402 MATERIALS**

#### **(a) Guardrails**

*Add to Sub-clause 5402 (a) the following:*

All holes in guardrail sections shall be drilled prior to galvanising. The Contractor shall submit SABS test certificates certifying the galvanising complies with the specification.

End treatment will involve the dipping of the last 3 sections of guardrails into the ground as detailed on the drawings.

#### **(b) Guardrail posts**

*Add to Sub-clause 5402 (b) the following:*

##### **(i) Timber posts**

“The tops of all timber guardrail posts and spacer blocks shall be sealed with a coat of 50/70 pen. bitumen. Galvanised gang-nail plates shall then be nailed on top of the guardrail posts.”

### **B5404 REQUIREMENTS**

*After the first paragraph at the start of Clause 5404, add the following:*

The vertical tolerance to which the completed guardrail shall comply shall be 3 mm. On straights and on curves the completed guard-rail shall not be out of line by more than 10 mm and 15 mm respectively.

**SECTION 5700: ROAD MARKING**

**B5702 MATERIALS**

**(a) Paint**

- (ii) Retro-reflective road-marking paint

*Add to Sub-clause 5702(a)(ii) the following:*

During actual painting the Contractor shall supply sealed samples of the paint to be used to the Engineer together with details of the paint batch numbers and testing carried out on these particular batches by the paint manufacturer to prove compliance with this specification. These samples shall be kept until the end of the defects liability period.

**B5704 MECHANICAL EQUIPMENT FOR PAINTING**

*Add to Clause 5704 the following:*

The machine shall always operate in the direction of the traffic when applying lane markings

## SECTION 5800: LANDSCAPING AND PLANTING PLANTS

### B5801 SCOPE AND DEFINITION

#### (a) Scope

Add to sub-clause 5801(a) the following:

The Contractor shall also note the requirements of the Environmental Management Procedures in Part C of these Project Specifications, with particular reference to the protection of existing trees and shrubs. Due to the nature of the project site, and the erosion which occurs when trees and grasses are removed, existing vegetation shall be disturbed as little as possible.

### B5812 MEASUREMENT AND PAYMENT

Add the following new Clause after the last paragraph of item 58.01:

<u>ITEM</u>		<u>UNIT</u>
B58.01	Trimming:	
	(a) Machine trimming	m <sup>2</sup>
	(b) Hand trimming	m <sup>2</sup>

A portion of this work shall include for labour intensive construction. The tenderer shall make allowance for the employment of local labour and/or the labour of local subcontractors, supplemented by the contractor's key personnel for the use of labour intensive construction.

Labour intensive construction specific to these activities shall be carried out subsequent to the training of local labour. Local labour shall be trained during workshops prior to works being carried out.

The labour intensive activities shall comprise of the following:

- a) Trimming the areas to the specified requirements;
- b) Moving of small quantity material; and
- c) Removal of surplus material and stone

Add the following new Clause after the last paragraph of item 58.03:

<u>ITEM</u>		<u>UNIT</u>
B58.03	Preparing the areas for grassing:	
	(a) Topsoiling within the road reserve, where the following materials are used:	
	(i) Topsoil obtained from within the road reserve or borrow areas (free haul 1,0km)	m <sup>3</sup>
	(b) Stockpiling of topsoil (free-haul 1,0km)	m <sup>3</sup>

A portion of this work shall include for labour intensive construction. The tenderer shall make allowance for the employment of local labour and/or the labour of local subcontractors, supplemented by the contractor's key personnel for the use of labour intensive construction.

Labour intensive construction specific to these activities shall be carried out subsequent to the training of local labour. Local labour shall be trained during workshops prior to works being carried out.

The labour intensive activities shall comprise of the following:

- a) Excavating and loading the topsoil;
- b) Placing and spreading the topsoil to required thickness;



- c) Levelling the topsoil to smooth surface and removing the stones; and
- d) Placing it in the stockpile

Add the following new Clauses after the last paragraph of item 58.04:

<b><u>ITEM</u></b>		<b><u>UNIT</u></b>
B58.04	Grassing:	
	(a) Sodding by using the following types of sods:	
	(i) Veld sods	m <sup>2</sup>

A portion of this work shall include for labour intensive construction. The tenderer shall make allowance for the employment of local labour and/or the labour of local subcontractors, supplemented by the contractor's key personnel for the use of labour intensive construction.

Labour intensive construction specific to these activities shall be carried out subsequent to the training of local labour. Local labour shall be trained during workshops prior to works being carried out.

The labour intensive activities shall comprise of the following:

- a) Excavating, loading, transporting, off-loading, placing and watering sods for replanting dead areas.

B58.04 Grassing:  
(continue  
d)

- (b) Hydroseeding:
  - (i) Hydroseeding ha

A portion of this work shall include for labour intensive construction. The tenderer shall make allowance for the employment of local labour and/or the labour of local subcontractors, supplemented by the contractor's key personnel for the use of labour intensive construction.

Labour intensive construction specific to these activities shall be carried out subsequent to the training of local labour. Local labour shall be trained during workshops prior to works being carried out.

The labour intensive activities shall comprise of the following:

- a) Mixing;
- b) Watering,
- c) Weeding and re-hydroseeding bare patches

### **C3.3: PARTICULAR SPECIFICATIONS**

#### **PART C: ENVIRONMENTAL MANAGEMENT SPECIFICATION**

##### **C.1 General**

In order to ensure that the construction work is carried out in an environmentally sensitive manner, strict compliance with the Environmental Management Plan (EMP) guidelines is required. The purpose of the EMP is to:

- Encourage good management practices through planning and commitment to environmental issues,
- Provide rational and practical environmental guidelines to:
  - Minimise disturbance of the natural environment,
  - Prevent pollution of land, air and water,
  - Prevent soil erosion and facilitate re-vegetation.
- Adopt the best practicable means available to prevent or minimise adverse environmental impact,
- Develop waste management practices based on prevention, minimisation, recycling, treatment or disposal of wastes,
- Train employees and contractors with regard to environmental obligations.

##### **C.2 Training and Induction of Employees**

- The Contractor has a responsibility to ensure that all those people involved in the project are aware of and familiar with the environmental requirements for the project (this includes subcontractors, casual labour, etc.). The EMP shall be part of the terms of reference for all contractors, subcontractors and suppliers.

##### **C.3 Complaints Register and Environmental Incident Book**

Any complaints received by the project team from the public will be recorded. The complaint should be brought to the attention of the Construction Manager, who will respond.

The following information must be recorded:

- Time, date and nature of the complaint,
- Type of communication (telephone, letter, etc.),
- Name, contact address and telephone number of the complainant,
- Response and investigation undertaken and
- Actions taken and by whom.

All complaints received will be investigated and a response given to the complainant within 14 days.

All environmental incidents occurring on the site will be recorded. The following information will be provided:

- Time, date, location and nature of the incident,
- Actions taken and by whom.

##### **C.4 Site Cleanliness and Neatness**

- Location of a construction camp is to be approved by the Employer's Agent and is to be restored to its previous condition after completion of construction.
- The construction camp should preferably be fenced with a 1.8m Bonnox fence or similar approved.
- All materials, equipment, plant and vehicles must be stored within the construction camp.
- A dedicated area must be made available for construction staff to change and store their personal belongings.

### **C.5 Access**

- i Access to existing roads, schools, buildings, shops and residential properties must not be impeded during construction.
- ii Access roads utilised by the Contractor must be maintained in good condition.

### **C.6 Borrow Pits**

- Mining authorisations (permits) for borrow pits must be obtained from the Department of Minerals and Energy (DME) in consultation with the Department of Water Affairs and Forestry (DWAF).
- Spoil dumps resulting from borrow pits must not interfere with any natural surface drainage.
- Borrow pits must be rehabilitated after use in accordance with the requirements of DME and DWAF.

### **C.7 Dust Control / Air Quality**

- Dust suppression measures must be implemented during construction by ensuring that all surfaces prone to dust generation are kept damp (e.g. use of water tanker).
- Ensure that vehicles and equipment are in good working condition and that emissions are not excessive.
- Special care must be taken in areas where the route passes close to schools and residential areas.
- The speed of construction vehicles must be reduced.

### **C.8 Fauna**

- Contractors and sub-contractors staff and workers may not chase, catch or kill animals encountered during construction.

### **C.9 Fire Prevention and Control**

- Smoking is prohibited in the vicinity of flammable substances.
- The Contractor must ensure that fire-fighting equipment is available on site, particularly where flammable substances are being stored or used, and that construction staff are aware of where it is kept and how it is operated.
- Fires started for comfort (warmth) are prohibited, due to the risk of veld fires and risk to adjacent property owners' lands.

### **C.10 Grave Sites**

- Gravesites in close proximity to the road must not be disturbed during construction.

### **C.11 Materials Handling and Spills Management**

- Any hazardous materials to be used during construction (e.g. lime, fuel, paint, etc..) are to be stored in a designated area at the campsite.
- The storage containers/facilities (including any diesel/petrol tanks) must be placed on an impermeable surface and surrounded by a bund wall, in order to ensure that accidental spillage does not pollute the environment.
- Workers must at all times be made aware of the health and safety risks associated with any hazardous substances used (e.g. smoking near fuel tanks), and must be provided with appropriate protective clothing/equipment in case of spillages or accidents.
- Ensure all staff and contractors undergo relevant training in the maintenance of equipment to prevent the accidental discharge or spill of fuel, oil, lubricants and other chemicals.
- Any spill of potentially hazardous materials must be cleaned up immediately (Potentially hazardous materials on site include paint, oil, grease, fuel, turpentine, etc..).
- The area of contaminated soil or spill must be deposited into the hazardous waste container(s).

- The Contractor should keep Peat Sorb or a similar absorbent on site to clean up any spills. The absorbent must be stored in a designated area and be available for inspection.
- All spills are to be recorded in the environmental incident book.

**C.12 Noise**

- Noise generating activities must be restricted to between 07h00 and 17h00 Monday to Friday, unless otherwise approved by the appropriate competent person in consultation with adjacent landowners/affected persons.
- All equipment, vehicles and machinery must be in good working condition and be equipped with sound mufflers if necessary.
- Construction staff must be trained and made aware of not creating unnecessary noise such as hooting and shouting.

**C.13 Pollution Control**

- Soil and water pollution through usage of fuel, oil, paint, bitumen or other hazardous substances must be avoided.
- All construction vehicles are to be maintained in good working order so as to prevent soil or water pollution from oil, fuel or other leaks, and to reduce noise pollution.

**C.14 Rivers and Streams**

- During construction of bridge structures, there must be no obstruction of the water flow of rivers and streams.
- Excavated material must not be stockpiled on or near riverbanks, in order to prevent sedimentation occurring.
- Erosion control measures must be employed both during and after construction.
- No impediments to natural surface water flow, other than approved erosion control measures, must occur.

**C.15 Safety**

- Safety measures, such as detour signs, must be implemented during construction to ensure the safety of workers, pedestrians and drivers/passengers in vehicles in the vicinity of construction work.
- Special care must be taken in the vicinity of schools to ensure the safety of children wishing to cross the road under construction.
- The relevant signage (e.g. speed control signs) must be erected alongside the road during the operation phase in order to control traffic.
- Accommodation must be made for pedestrian pathways alongside the road during the construction and operation phases.

**C.16 Soil Management**

- Storm water drainage pipes must be installed alongside the road in all areas susceptible to soil erosion.
- Erosion should be minimised by the construction of meadow drains and the planting of indigenous vegetation on the side slopes and drains to reduce flow velocity of storm water.
- Spoil from cuts may be used in existing erosion gullies.
- Stone pitching and gabions should be constructed at pipe culvert outlets.
- Accidental spills of contaminants onto the ground e.g. oil, concrete, fuel and chemicals should be removed together with the contaminated soil.

- If necessary an absorbent such as Peat Sorb should be used to aid in cleaning up the spill. The contaminated soil should be disposed of in an appropriate container, depending on its classification.
- Servicing and refuelling of vehicles must only be carried out at the construction camp.

### **C.17 Worker Conduct**

Code of Conduct for Construction Personnel:

- Do not leave the construction site untidy and strewn with rubbish which will attract animal pests.
- Do not set fires.
- Do not cause any unnecessary, disturbing noise at the construction camp/site or at any designated worker collection/drop off points.
- Do not drive a construction-related vehicle under the influence of alcohol.
- Do not exceed the national speed limits on public roads or exceed the recommended speed limits on the site.
- Do not drive a vehicle which is generating excessive noise or gaseous pollution (noisy vehicles must be reported and repaired as soon as possible).
- Do not litter along the roadsides, including both the public and private roads.
- Do not pollute any water bodies (whether flowing or not).
- No member of the construction team is allowed to enter the areas outside the construction site.

### **C.18 Traffic Disturbances and Diversions**

- Any traffic diversions must be undertaken with the approval of all relevant authorities and in accordance with all relevant legislation.
- Wherever possible, traffic diversion must only take place on existing disturbed areas and remain within the existing road reserve.
- Traffic diversion routes must be rehabilitated after use.

### **C.19 Vegetation**

- Only vegetation falling directly on the route must be removed where necessary.
- Alien vegetation within the road reserve must be eradicated, and management measures must be implemented for future control of these species.
- Vegetation that has been removed from large areas (e.g. on traffic diversion routes) during construction must be replaced with indigenous vegetation after construction has been completed.

### **C.20 Waste Management**

- All general, non-hazardous waste must be placed in a skip container and disposed of at a registered waste disposal site.
- The Contractor is to ensure that the portable toilet facilities at the campsite are properly maintained and in working order.
- No disposal, or leakage, of sewage must occur on or near the site.
- All hazardous waste (e.g. oil, paint, empty lime bags, contaminated wash water, etc.,) must be stored in leakproof containers and disposed of at a registered hazardous waste disposal site.
- The contents of waste storage containers must, under no circumstances, be emptied to the surrounding area. In general, littering, discarding or burying of any materials is not allowed on site or along the route.
- Adequate waste receptacles must be available at strategic points around the construction camp and site for all domestic refuse and to minimise the occurrence of littering.
- Concrete rubble must be collected and disposed of as directed by the Employer's Agent.

- Each working area must be cleared of litter and building waste (e.g. rubble, wood, concrete packets, etc.) on completion of the day's work.

Any spill around the container(s) should be treated as per Section C.11 and C.16.

In line with the municipality's COMPULSORY SUBCONTRACTING policy, as captured in clause 2 (1) (a) (ii) of the approved *Supply Chain Management Policy*; "all contracts with a value from R5 000 000 and above" are subject to a compulsory subcontracting. In terms of this clause, the successful Tenderer (Main contractor) is compelled to Sub-contracting a minimum of 30 % of the contract value. The subcontract firms shall be;

- in the Level 1 CIDB grading category of the specific project category (GB, CE, etc.);
- residents of DR NKOSAZANA DLAMINI ZUMA MUNICIPALITY,
- Black owned emerging contractor entities. Preference should be given to youth, disabled and female contractors or co-operatives.

The 30% requirement shall not be made up entirely of construction materials sourcing, this aspect will be capped at 10%.

Allocations will be made within the Bill of Quantities for specific works to be done by subcontractors, with an allocation for the full-time supervision by the Main Contractor. The works produced by the subcontractor is solely the responsibility of the Main Contractor.

A list of subcontractors meeting a pre-qualifying criterion will be provided to the Main Contractor by the municipality. However, the municipality indemnifies itself from any claim that may arise in the event of a dispute herein.

## **PART D: DAYWORK**

This part of the Particular Specifications deals with the provision for daywork in the Schedule of Quantities. Rates for daywork shall be entered in the Schedule of Quantities in accordance with the following specifications.

### **D1. SCOPE**

According to Clause 6.5 of the General Conditions of Contract 2015, certain work may be carried out using rates tendered in the daywork schedule. A schedule of personnel, plant and equipment which may be necessary to perform work on a daywork basis is included in the Schedule of Quantities. The quantities used in the Schedule of Quantities are for tender evaluation purposes only and the use or not of these items shall not constitute a variation in terms of Clause 6.3 of the General Conditions of Contract 2015.

No work will be paid for as daywork without the written instruction or approval of the Employer's Agent.

### **D2. TYPE OF WORK**

The Employer's Agent may order daywork in certain cases where it is necessary to vary or to extend the works due to new or unforeseen circumstances to such an extent that the tendered rates for specific items of work are no longer applicable, or where no suitable combination of tendered rates can be used to pay for such work.

As a general rule, applicable rates for additional work items will be agreed between the Contractor and the Employer's Agent. Daywork will only be used in exceptional circumstances.

### **D3. MATERIALS**

Materials for use in works carried out under daywork shall be purchased by the Contractor who shall also arrange for delivery to site, and shall be responsible for any other requirements associated with specific materials. A Provisional Sum has been allowed in Section D of the Schedule of Quantities for daywork materials. The Contractor shall enter a tendered percentage in the Schedule of Quantities to cover his handling costs and profit, as per other provisional and prime cost sums in this Contract.

Materials shall be paid for using the method described in C2.1, 'Pricing Instructions'. No contract price adjustment will be applicable to materials.

The Contractor shall submit proof of ownership for any materials used in daywork with his daywork claim to the Employer's Agent. Further, if specific materials are required for daywork, quotations will be called for as per Clause 6.5.2 of the General Conditions of Contract 2015.

### **D4. CONSTRUCTION PLANT HIRE**

Where daywork is ordered, the tendered rates for plant hire in Section D of the Schedule of Quantities shall be used in calculating the payment due for any plant required to execute the daywork. If no rate is included in the Schedule of Quantities for a particular piece of equipment, and where no other rate or combination of rates would provide suitable compensation, then the daywork method of payment described in Clause 6.5.1.3 of the General Conditions of Contract 2015 will be used.

The tendered rates for each item of constructional plant shall include for all operating costs associated with the said item of plant. Such costs are deemed to include fuel, re-fuelling costs, lubrication and routine servicing / maintenance, breakdowns and spares, all overhead costs, site management costs and administration costs. The tendered rates shall also include the plant operator and the general supervision of the plant while it is engaged in the daywork.

### **D5. SALARIES AND WAGES OF WORKMEN**

The salaries and wages of workmen executing daywork shall be paid for using the tendered rates in the Schedule of Quantities. The tendered rates shall include for all costs associated with the employment of personnel, including salaries, wages, allowances, workmen's compensation, medical aid and pension contributions, government levies and taxes, training costs and any costs associated with living on the site. The tendered rates shall also include for the transportation of the workmen to the site of the daywork.

All overhead costs, administration costs, site management costs and the Contractor's profit are deemed to be covered by the daywork rates and no additions or mark ups will be made to the tendered rates.

The tendered rates shall also include any hand tools normally associated with the workmen's job description e.g. picks, shovels, hammers, saws, spirit levels, etc. The tendered rate for labourers shall also include for the casual supervision by a gang boss or foreman. Only when specifically called for by the Employer's Agent, will payment be made for the use of a gang boss or foreman supervising on a continuous basis.

#### **D6. MEASUREMENT AND PAYMENT**

The following principles shall also apply to the measurement and payment of daywork.

The unit of measurement for plant shall be the number of Vibroclock hours worked and each item of plant shall be fitted with a Vibroclock, the cost of which shall be included in the rates. Excessive non-productive time when the engine is idling will not be paid for. Where there is ambiguity between the flywheel horsepower and mass of the machine, the flywheel horsepower shall govern the measurement category. Where width and mass are specified, mass shall govern the measurement category.

The Contractor's attention is drawn to the requirements of Clauses 6.5.3 and 6.5.4 of the General Conditions of Contract 2015 with regard to the submission of daywork claims.



## PART E: OHSA 1993 HEALTH AND SAFETY SPECIFICATION

### E1. SCOPE

This specification covers the health and safety requirements to be met by the Contractor to ensure a continued safe and healthy working environment for all employees, subcontractors, the Employer, the Employer's Agent, inspectors and all other persons entering the site of works.

This specification shall be read in conjunction with the Occupational Health and Safety Act (Act No 85 and amendment Act No 181) 1993 and the corresponding Construction Regulations 2014, and all other safety codes and specifications referred to in the said Act and Construction Regulations.

In terms of the OHSA Agreement in Section C1.4 of the Contract document, the status of the Contractor as mandatory to the Employer (client) is that of an employer in his own right, responsible for compliance with all provisions of OHSA 1993 and the Construction Regulations 2014.

This specification and the Contractor's own Health and Safety Plan as well as the Construction Regulations 2014, shall be displayed on site or made available for inspection by inspectors, the Employer, the Employer's Agent, subcontractors, employees, representatives of trade unions and any other persons entering the site of works.

#### E1.1 Information based on the Employer's baseline risk assessment

The information presented in this subclause E1.1 is based on the Employer's baseline risk assessment prepared specifically for this contract.

This information describes the type of work required in terms of this contract that will be accompanied by dangers, hazards and risks which the Contractor shall be required to identify, analyse, manage, monitor and review in terms of the Health and Safety Plan and risk assessments.

This information is neither prescriptive nor exhaustive and is provided as a guideline to Tenderers in preparing their tender submissions, and to the successful Contractor as a basis for the preparation of the site-specific risk assessments to be performed by the Contractor in terms of Construction Regulation 9.

Tenderers shall make their own assessment of the dangers, hazards and risks that can be expected during the course of this contract, which may include dangers, hazards and risks not identified in the baseline risk assessment, including those that may arise from specific methods of construction employed by the Contractor, and shall make due allowance in their tendered rates and prices for all costs related to complying with the provisions of the Act and Construction Regulations.

This information is given in good faith for the guidance of Tenderers, and no additional payment shall be made as a result of any inaccuracies, discrepancies or omissions contained therein.

The following aspects of this project carry the risk of possible injuries:

- Operation and maintenance on the site of heavy civil engineering plant such as excavators, bulldozers, front end loaders, tippers, TLBs, compaction equipment, rock breaking plant, water pumps, concrete mixers, ready mixed concrete trucks, batch plants, cranes, concrete pumps, compressors, pneumatic tools, generators, etc.
- Use on the site of power tools and hand tools.
- Handling of materials such as scaffolding, formwork, timber planks, steel wire, reinforcement, cement bags, concrete materials and hand stone.
- Storage and handling of flammable materials such as fuels, oils, adhesives, and painting and cleaning products including bituminous paint.
- Storage and handling of herbicides and ant poisons.
- Presence of open excavations for the box culvert, manholes and stormwater pipe trenches.
- Risks related to general safety and security on site.

Additional risks may arise from specific methods of construction selected by the Contractor which are not necessarily covered in the above.

## E2. DEFINITIONS

For the purpose of this contract the following shall apply:

- (a) **Employer** where used in the contract documents and in this specification, means the Employer as defined in the General Conditions of Contract 2015 and it shall have the exact same meaning as **client** as defined in the Construction Regulations 2014. **Employer** and **client** are therefore interchangeable and shall be read in the context of the relevant document.
- (b) **Contractor** wherever used in the contract documents and in this specification, shall have the same meaning as **Contractor** as defined in the General Conditions of Contract 2015.

In this specification the terms **principal contractor** and **contractor** are replaced with **Contractor** and **subcontractor** respectively.

For the purpose of this contract the **Contractor** will, in terms of OHS Act 1993, be the mandatory, without derogating from his status as an employer in his own right.

- (c) **Employer's Agent** where used in this specification, means the Employer's Agent as defined in the General Conditions of Contract 2015. In terms of the Construction Regulations the Employer's Agent may act as agent on behalf of the Employer (the client as defined in the Construction Regulations).

## E3. TENDERS

This Health and Safety Specification forms an integral part of the Contract and Tenderers are required to use it during the tender phase for pricing the preparation of a project specific Health and Safety Plan prior to commencing any work and for pricing the costs of ensuring compliance thereto during construction. Tenderers must forward a copy of this Specification to all other persons or organisations that may be submitting prices to the Tenderer during the tender stage to enable them to include the cost of preparing their own Health and Safety Plan, relevant to their particular operation, and for compliance with the health and safety requirements during construction. Payment items are included in the Schedule of Quantities for compliance with the Occupational Health and Safety Act and Construction Regulations and with this Specification.

Tenderers are required to complete Form J 'Contractor's Health and Safety Declaration' in section T2.2 'Returnable Schedules'.

Failure to submit the foregoing with his tender and/or to provide realistic rates for relevant payment items will lead to the conclusion that the Contractor will not be able to carry out the work under the contract safely, in accordance with the Act and Construction Regulations and his tender shall be deemed non-responsive.

## E4. NOTIFICATION OF COMMENCEMENT OF CONSTRUCTION WORK

Where the contract meets the requirements of Construction Regulation 4, the Contractor shall, before commencement of the work and in accordance with the requirements of Regulation 4, notify the Provincial Director of the Department of Labour of the intention to carry out the construction work, using the pro forma form included as Annexure 2 to this Health and Safety Specification.

A copy of the notification form must be kept on site, available for inspection by inspectors, the Employer, the Employer's Agent, subcontractors, employees, representative trade unions and any other persons on the site. A copy of the notification form shall also be kept on the health and safety file, and a further copy shall be forwarded to the Employer for his records.

## E5. HEALTH AND SAFETY PLAN

Before commencement of any construction work, the Contractor shall prepare a project specific Health and Safety Plan complying with the requirements of Construction Regulation 7(1)(a) and this Health and Safety Specification.

The Health and Safety Plan must include a risk assessment performed and recorded in writing by a competent person as required in terms of Construction Regulation 9. The risk assessment shall identify and evaluate the risks and hazards that may be expected during the execution of the work under the contract, and it shall include

a documented plan and applicable safe work procedures to mitigate, reduce or control the risks and hazards identified.

The Health and Safety Plan shall be available on site for inspection by inspectors, the Employer, the Employer's Agent, subcontractors, employees, representative trade unions, and health and safety representatives and committee members, and must be monitored and reviewed periodically by the Contractor.

## **E6. APPOINTMENT OF EMPLOYEES AND SUBCONTRACTORS**

### **E6.1 Appointments**

The Contractor shall appoint in writing all employees.

The Contractor shall appoint in writing all subcontractors, and such appointments shall be in compliance with the requirements of Construction Regulation 7.

### **E6.2 Health and safety induction training**

No person shall be allowed or permitted to enter the site of the works unless such person has undergone health and safety induction training pertaining to the hazards prevalent on the site.

The Contractor shall ensure that all employees under his control, including subcontractors and their employees, undergo health and safety induction training by a competent person before commencement of construction work in compliance with Construction Regulations 7(5) and 9(3) and (4).

The Contractor shall ensure that all visitors to the construction site undergo health and safety induction and are provided with the necessary personal protective equipment in compliance with Construction Regulation 7(6).

### **E6.3 Medical certificate of fitness**

The Contractor shall ensure that every employee, including subcontractors and their employees, has a valid medical certificate of fitness issued in compliance with Construction Regulation 7(1)(g) or 7(8) as applicable.

## **E7. APPOINTMENT OF SAFETY PERSONNEL**

### **E7.1 Construction manager**

Refer to Construction Regulation 8(1), (2), (3) and (4).

The Contractor shall appoint a full-time **Construction Manager** with the duty of managing all the construction work on the site, including the duty of ensuring occupational health and safety compliance.

The Contractor may also have to appoint one or more **assistant construction managers** to assist the Construction Manager where justified by the scope and complexity of the works.

### **E7.2 Construction health and safety officer**

Refer to Construction Regulation 8(5) and (6).

Taking into consideration the size of the project and the dangers, hazards or risks that can be expected, the Contractor shall appoint in writing a full-time or part-time **construction health and safety officer** to assist in the control of all health and safety related aspects on the site. The construction health and safety officer shall be registered as required by the Chief Inspector of the Department of Labour and shall have the necessary competence and resources to perform his/her duties diligently.

### **E7.3 Construction supervisor**

Refer to Construction Regulation 8(7), (8), (9) and (10).

The Contractor shall appoint a **construction superintendent** responsible for construction activities and ensuring occupational health and safety compliance on the construction site.

The Contractor may also have to appoint one or more competent employees to assist the construction superintendent where justified by the scope and complexity of the works.

#### **E7.4 Health and safety representatives**

In terms of **Sections 17 and 18 of the Act (OHSA 1993)** the Contractor, being the employer in terms of the Act for the execution of the contract, shall appoint a **health and safety representative** whenever he has more than 20 employees in his employment on the site of the works. The health and safety representative must be selected from employees who are employed in a full-time capacity at a specific workplace.

The number of health and safety representatives for a workplace shall be at least one for every 50 employees.

The function of health and safety representative(s) will be to review the effectiveness of health and safety measures, to identify potential hazards and major incidents, to examine causes of incidents (in collaboration with his employer, the Contractor), to investigate complaints by employees relating to health and safety at work, to make representations to the employer (Contractor) or inspector on general matters affecting the health and safety of employees, to inspect the workplace, plant, machinery, etc. on a regular basis, to participate in consultations with inspectors and to attend meetings of the health and safety committee.

#### **E7.5 Health and safety committee**

In terms of **Section 19 of the Act (OHSA 1993)**, the Contractor (as employer) shall establish one or more **health and safety committee(s)** where there are two or more health and safety representatives at a workplace. The persons selected by the Contractor to serve on the committee shall be designated in writing.

The function of the health and safety committee shall be to hold meetings at regular intervals but at least once every three months, to review the health and safety measures on the contract, to discuss incidents related to health and safety with the Contractor and the inspector, to make recommendations regarding health and safety to the Contractor and to keep record of recommendations and reports made by the committee.

#### **E7.6 Competent persons**

The Contractor shall appoint in writing designated competent employees and/or other competent persons as required by the Act and Regulations. Such appointments shall be in accordance with the relevant applicable sections of the Act and Regulations as determined by the requirements of the contract.

A competent person may be appointed for more than one part of the construction work with the understanding that the person must be suitably qualified and able to supervise at the same time the construction work in all the work situations for which he has been appointed.

The appointment of competent persons to supervise parts of the construction work does not relieve the Contractor from any of his responsibilities for compliance with **all** requirements of the Construction Regulations.

### **E8. RECORDS AND REGISTERS**

The Contractor is bound to keep records and registers related to health and safety on site as required by the relevant applicable sections of the Act and Regulations as determined by the requirements of the contract. Such records and registers shall be available for periodic inspection by inspectors, the Employer, the Employer's Agent, subcontractors, employees and representatives of trade unions.

### **E9. CONTRACTOR'S RESPONSIBILITIES**

For this contract the Contractor will be the mandatary of the Employer (Client), as defined in the Act (OHSA 1993), which means that the Contractor has the status of employer in his own right in respect of the contract. The Contractor is therefore responsible for all the duties and obligations of an employer as set out in the Act (OHSA 1993) and the Construction Regulations 2014.

Before commencement of work under the contract, the Contractor shall enter into an agreement with the Employer (Client) in terms of C1.4 'Agreement in terms of Section 37(2) of the Occupational Health and Safety Act No. 85 of 1993', to confirm his status as mandatary (employer) for the contract under consideration.

***The Contractor is advised in his own interest to make a careful study of the Act and the Construction Regulations as ignorance of the Act and the Regulations will not be accepted in any proceedings related to non-conformance to the Act and the Regulations.***

#### **E10. MEASUREMENT AND PAYMENT**

It is a condition of this contract that contractors who submit tenders for this contract shall make provision in their various tendered rates and prices for all costs related to the health and safety measures required in terms of the Act and Regulations during the construction process.

(a) Safety appointments

No separate additional payment will be made to cover the costs related to persons appointed as required in terms of the Act and Regulations to fulfil the various health and safety functions. Such persons include the Construction Manager, any assistant construction managers, the construction health and safety officer, the construction superintendent, any assistant construction superintendents, health and safety representatives, health and safety committee members and competent persons, all as referred to in subclauses E7.1 to E7.6 above. The Contractor shall therefore make provision in the various tendered rates and prices for all costs related to such persons.

(b) Records and registers

The keeping of records and registers related to health and safety on site as described in clause E8 above shall be regarded as a normal duty of the Contractor for which payment shall be deemed to be included in the Contractor's various tendered rates and prices, and for which no separate additional payment will be made except to the extent provided in item B13.02 of the Schedule of Quantities.

(c) Medical certificates

No separate additional payment will be made to cover the costs related to obtaining the medical certificates of fitness required for every employee, including subcontractors and their employees, issued in compliance with Construction Regulation 7(1)(g) or 7(8) as applicable. The Contractor shall therefore make provision in the various tendered rates and prices for all costs related to such medical certificates.

## **PART F: REQUIREMENTS OF THE EXPANDED PUBLIC WORKS PROGRAMME (EPWP)**

### **F1. INTRODUCTION**

The Expanded Public Works Programme (EPWP) is a multi-sectoral government initiative to create jobs. In the case of the infrastructure sector, existing government expenditure is realigned using labour intensive technologies to create job opportunities. This involves the use of plant and labour, where labour is preferred and plant is used appropriately.

As much as is economically feasible, all work shall be implemented by employing Labour Intensive Construction methods. Over and above the normal Building and Allied works to be implemented by employing skilled and unskilled labour the works specified in the "Guidelines for the Implementation of Labour-Intensive Infrastructure Projects under the Expanded Public Works Programme (EPWP)" shall be undertaken using Labour Intensive Construction methods.

#### **F1.1. Employment of Unskilled and Semi-Skilled Workers in Labour Intensive Works**

Requirements for the sourcing and engagement of labour.

1.1.1 Unskilled and semi-skilled labour required for the execution of all labour intensive works shall be engaged strictly in accordance with prevailing legislation and SANS 1914-5, Participation of Targeted Labour.

1.1.2. The rate of pay set for the EPWP is R 29.37 per hour.

1.1.3. Tasks established by the contractor must be such that:

- a) The average worker completes 5 tasks per week in 40 hours or less; and
- b) the weakest worker completes 5 tasks per week in 55 hours or less.

1.1.4. The contractor must revise the time taken to complete a task whenever it is established that the time taken to complete a weekly task is not within the requirements of 1.1.3.

1.1.5. The Contractor shall, through all available community structures, inform the local community of the labour intensive works and the employment opportunities presented thereby. Preference must be given to people with previous practical experience in construction and / or who come from households:

- a) Where the head of the household has less than a primary school education;
- b) That have less than one full time person earning an income;
- c) Where subsistence agriculture is the source of income; and
- d) Those who are not in receipt of any social security pension income.

1.1.6. The Contractor shall endeavour to ensure that the expenditure on the employment of temporary workers is in the following proportions:

- a) 55 % women;
- b) 55% youth who are between the ages of 18 and 35; and
- c) 2% on persons with disabilities.

**Note:** The Contractor shall not be required to employ NYS youth workers in terms of this contract.

#### **F1.2. Payment for the Labour-Intensive Component of the Works**

Those parts of the works to be constructed using labour-intensive methods are marked in the bill of quantities with the letters LI either in a separate column or as a prefix or suffix against every item so designated. The works, or parts of the works so designated are to be constructed using labour-intensive methods only. The use of plant to provide such works, other than plant specifically provided for in the scope of work, is a deviation from the contract. The items marked with the letters LI are not necessarily an exhaustive list of all the activities which must be done by hand and this clause does not over-ride any of the requirements in the generic labour-intensive specification in the Scope of Works.

Where minimum labour intensity is specified in the design, the contractor is expected to use their initiative to identify additional activities that can be done labour-intensively in order to comply with the set minimum labour intensity targets.

Payment for items which are designated to be constructed labour-intensively (either in this schedule or in the Scope of Works) will not be made unless they are constructed using labour-intensive methods. Any unauthorised use of plant to carry out work which was to be done labour-intensively will not be condoned and any works so constructed will not be certified for payment. Any non-payment for such works shall not relieve the Contractor in any way from his obligations either in contract or in delict.

### **F1.3. Linkage of Payment for Labour-Intensive Component of Works to Submission of Project Data**

The Contractor's payment invoices shall be accompanied by labour information for the corresponding period in a format specified by the employer. If the contractor chooses to delay submitting payment invoices, labour returns shall still be submitted as per frequency and timeframes stipulated by the Employer. The contractor's invoices shall not be paid until all pending labour information has been submitted. The client may institute a penalty relating to outstanding labour information.

The following information shall be maintained on site and submitted monthly in electronic/hard copy formats:

- Certified ID copies of all locally employed labour;
- Signed Contracts between the employer and the EPWP Participants;
- Attendance Registers for the EPWP Participants;
- Proof of Payment of EPWP Employees; and
- Monthly Reporting Template as per EPWP requirements.

### **F1.4. Training of EPWP workers**

All EPWP workers will be placed on an extensive training programme that will include:

- (a) an induction into EPWP;
- (b) life skills training;
- (c) technical training focusing on a vocational skill to be used on the project (e.g., painting, carpentry, etc.);
- (d) entrepreneurship and business skills training.

All training will be arranged by the EPWP programme manager, with whom the Contractor will be required to work closely to schedule the training sessions so that the timing of the training is aligned with the Contractor's work schedule and his demand for workers with specific skills. The EPWP programme manager will make full details of the training programme available to the Contractor.

The Contractor shall maintain comprehensive records of the training received by each EPWP worker throughout the course of the contract, and shall submit to the Employer at each monthly site meeting a summary of the accumulated training received by each EPWP worker.

The training venue facility to be provided by the Contractor shall be constructed, furnished and fully serviced for the duration of the contract in accordance with section 1400 of the COLTO standard specifications. The facility shall accommodate a class of up to 10 learners and shall comprise the following:

(a)	Lecture room (interior area)	=	24 m <sup>2</sup>
(b)	Ablutions (male)	=	6 m <sup>2</sup>
(c)	Ablutions (female)	=	6 m <sup>2</sup>
(d)	Chairs for learners (individual chairs, with backs)	=	10 off
(e)	Desk area for 10 learners (500 mm width)	=	5 m <sup>2</sup>
(f)	Chairs for trainers and management (individual chairs, with backs)	=	3 off
(g)	Table area for trainers and management	=	3 m <sup>2</sup>
(h)	220/250 volt power points	=	4 off
(i)	Double 80 watt fluorescent light fittings complete with ballast and tubes	=	4 off
(j)	Single incandescent light fittings complete with 100 watt globes	=	4 off
(k)	Wash hand basins complete with taps and drains	=	2 off
(l)	Fire extinguishers, 9,0 kg, all purpose dry powder type, complete, mounted on wall with brackets	=	2 off

(m)	Air conditioning units with 2,2 kW minimum capacity, mounted and with own power connection	=	2 off
(n)	Voltage stabilizers	=	2 off
(o)	Floodlights complete with poles and 500 Watt minimum globes and controlled by photocells	=	2 off
(p)	White boards (3 m x 1,5 m)	=	1 off
(q)	Venetian blinds	=	6 m <sup>2</sup>

#### **F1.5. Contractor's obligations towards persons employed under the EPWP programme**

All persons employed under the EPWP programme are to comply with the Ministerial Determination 4: Expanded Public Works Programmes, issued in terms of the Basic Conditions of Employment act of 1997 by the Minister of Labour in Government Notice NR347 of 4 May 2012. This document notes that the sector rates for labour do not apply to employees under the EPWP programme. Over and above implementing in accordance with the Ministerial Determination 4: Expanded Public Works Programmes, issued in terms of the Basic Conditions of Employment act of 1997 by the Minister of Labour in Government Notice NR347 of 4 May 2012, it shall be the responsibility of the Contractor to carry out the following functions with respect to the EPWP programme worker beneficiaries:

- (a) ensure that all beneficiaries receive induction on site safety prior to commencing with work on site;
- (b) ensure that all beneficiaries are covered by the Compensation for Occupational Injuries and Diseases Act, 1993 for as long as they are contracted to the Contractor, and to pay in full to the Compensation Commissioner such amounts as are due in terms of the Act;
- (c) implement health and safety procedures with respect to the beneficiaries, ensuring that the health and safety regulations are adhered to;
- (d) provide all beneficiaries with the necessary protective clothing and equipment as required by law for the specific trades in which the beneficiaries are involved, in addition to the overalls stipulated for EPWP workers;
- (e) assist in the assessment of beneficiaries with regards to their competencies in their respective trades;
- (f) provide overall supervision and day-to-day management of beneficiaries;
- (g) implement strict quality control to ensure that the work carried out by the beneficiaries is of the required standard, and, where necessary, to train and mentor the beneficiaries to assist them in achieving the standards required;
- (h) ensure that all beneficiaries are paid their wages on time through the pre-agreed payment method as stipulated in the beneficiary contract;
- (i) provide safe on-site storage facilities for tools and apparel issued to the beneficiaries.

#### **F1.6. Apparel and tools for EPWP workers**

The Contractor will provide each EPWP worker with two orange overalls with markings as specified in F5. EPWP BRANDING SPECIFICATION.

The Contractor shall also provide the EPWP workers with all such listed tools and apparel necessary for their on-site work, including appropriate safety apparel, as well as with safe storage facilities on site, the cost of which shall be refunded to the Contractor through the provisional sums included in the Schedule of Quantities for this purpose. The EPWP workers shall be responsible for the safe on-site storage of all tools and apparel issued to them, using the storage facilities provided on site by the Contractor.

Certain specified apparel and tools issued to the EPWP workers will become the property of the EPWP workers after the completion of their cycle of work on the project, in order to enable them to continue to practise their trade on future projects. Such apparel and tools shall be specified and authorised by the Employer's Agent.



## **F2. JOB CREATION REPORTING FOR EPWP**

In order to assist the Employer in complying with the goals of creating EPWP job opportunities, the Contractor must provide the following information for reporting purposes:

### **F2.1 Type of project data required per project**

Every EPWP project shall collect and keep specific project data for the purpose of EPWP progress reporting. The data that is required to be kept and maintained for each project includes:

#### **F2.1.1 Participant data**

A participant list must be maintained for every project. The data required in this participant list is indicated below. This data shall be recorded, checked and signed off by the Contractor on a weekly basis, and shall be submitted to the Employer at each monthly site meeting. The participant list shall contain the following data and shall be kept and maintained on site for audit purposes:

- (a) Participant identity – name, surname, initials, date of birth and identity number (or other unique identifier) plus certified copy of ID book, certified in the calendar year, address and contact number.
- (b) Participant profiles – nationality, gender, age, education level, language(s), government grant and disability status.
- (c) Monthly work data for participants – daily wage to be received, number of calendar days training attended and number of calendar days worked. Participants cannot work more than 23 days in any given month.

#### **F2.1.2 Project work data**

This generally seeks to confirm the number of people at work daily on the project. The following data must be recorded and maintained on site by the Contractor, in order that it can be provided by the Employer to the National Department of Public Works upon request when the latter is undertaking sample auditing. The documentation that should be kept includes:

- (a) Daily attendance register – register for each day showing all the workers that were registered as being at work on that day. Attendance registers shall be completed on site on a daily basis and signed off by the Contractor on a weekly basis.
- (b) Summary of monthly attendance.
- (c) Training register for each training course undertaken. This includes both formal and informal training such as induction, toolbox talks and on-the-job training. The training register must detail:

- Training course
- The accreditation of the course (accredited or non-accredited)
- Training provider
- ID number of participant trained
- Name and Surname of participant trained
- Gender of participant trained
- Signature of participant
- Duration of training

#### **F2.1.3 Project payment data**

This generally seeks to confirm what was paid, for how much work and to whom. It is required that the Contractor adopt one of the following methods as standard procedure for recording and maintaining this information:

- (a) Payment register – this is a list of the workers showing the wages paid to each worker, and signed off by each worker as proof of receipt and acceptance of payment. Information on this register must include the name of the worker, either an identity number or other unique identifier, the number of calendar days that the pay period covers, the wage rate and the total wages paid.

**Alternatively,**

(b) Bank records showing the transfers to each worker account, signed off by the Contractor as proof of payment – these bank records must specifically show the name of the worker, either an identity number or other unique identifier, the period which the pay covers and the total wages paid.

*The project payment data, as recorded and maintained by the Contractor in terms of either (a) or (b) above, must be available and applicable for the entire period for which the Employer claims an incentive reward for person-days of work created in terms of the project.*

**F2.1.4 Employment output data**

The Contractor shall submit to the Employer at each monthly site meeting the data necessary to enable the Employer to calculate the following employment output data:

- (a) Number of work opportunities created (where one work opportunity = paid work created for one individual on an EPWP project, for any period of time).
- (b) Number of person-days of work created (where one person-day = one day of work carried out by one individual). The total number of person-days of work created on a particular EPWP project shall be obtained by summing the total number of person-days worked by each individual employed during the course of that EPWP project.
- (c) Number of Full Time Equivalents (FTEs) created (= total number of person-days of work created on the EPWP project divided by 230 working days). In terms of EPWP policy, one year of work created for one individual is assumed to comprise a total of 230 days of paid work carried out by that individual.
- (d) Average duration of work opportunities created (= total number of person-days of work created on the EPWP project divided by the number of work opportunities created on that EPWP project).
- (e) Average daily wage rates paid (= accumulated total of the wages paid to all individuals employed on an EPWP project divided by the total number of person-days of work created on that EPWP project).

The above information is to be compiled and submitted to the Employer by the 2<sup>nd</sup> of each month in addition to a completed latest revision of the EPWP reporting tool received from the Employer.

**F3. PROVISION OF TRAINING**

This specification covers the requirements for the provision of training to be arranged by the contractor over the period of this contract.

**F3.1. Generic Training**

3.1.1. The contractor shall, from the commencement of the contract, implement a structured progressive training programme for local workers who meet the minimum criteria for the training courses.

3.1.2. The generic training will inter alia comprise, but not be limited to the following subjects:

Course Description	Estimated No. of Trainees	Estimated Duration (Days)
1. Road safety for construction workers		.....
2. Flagmen		.....
3. Concrete handling, placing and finishing		.....
4. Guardrails		.....
5. Bituminous road surfacing		.....

3.1.3. Training shall be at or by an approved accredited organisation and shall be delivered by suitably qualified and experienced trainers.

3.1.4. The tenderer shall provide with his tender full details of the structured training programme he intends to implement; which details shall include the following:

- (a) The name of the training institution and programme;
- (b) The manner in which the training is to be delivered; and
- (c) The numbers and details of the trainers.

Such details shall be entered on or attached to Returnable Schedule P included herein.

3.1.5. The contractor shall be responsible for the provision of everything necessary for the delivery of the generic training programme, including the following:

- (a) A suitable venue with sufficient furniture, lighting and power;
- (b) All necessary stationery consumables and study material;
- (c) Transport of the students (as necessary);
- (d) Payment of wage to all trainees during the classroom training at a rate equal to the minimum wage as set in the Ministerial Determination for the Expanded Public Works Programme on an annual basis;
- (e) Relevant PPE required for the project works; and
- (f) Additional supervision of learners during the practical learning stages of the works. Wage for the learners during this stage of the training will be paid through the outputs.

3.1.6. Generic training courses shall commence within one month of possession of site and be completed before the end of the contract period.

3.1.7. The contractor's training programme shall be subject to the approval of the engineer, and the contractor shall if so instructed by the engineer alter or amend the programme and course content if a need is identified once the contract commences.

3.1.8. The contractor shall keep comprehensive records of the training given to each student and whenever required shall provide copies of such records to the engineer. At the successful completion of each course each student shall be issued with a certificate indicating the course contents as proof of attendance and completion.

In addition to the above, a monthly return shall be submitted by the contractor. An example of the form is illustrated in Section C4.7 of this document.

#### **F4. PERSONAL & OTHER PROTECTIVE EQUIPMENT (SECTIONS 8/15/23 OR THE OHS ACT)**

The Contractor is required to identify the hazards in the workplace and deal with them. He must either remove them or, where impracticable take steps to protect workers and make it possible for them to work safely and without risk to health under the hazardous conditions.

Personal Protective equipment (PPE) should, however, be the last resort and there should always first be an attempt to apply engineering and other solutions to mitigating hazardous situations before the issuing of PPE is considered.

Where it is not possible to create an absolutely safe and healthy workplace the Contractor is required to inform employees regarding this and issue, free of charge, suitable equipment to protect them from any hazards being present and that allows them to work safely and without risk to health in the hazardous environment.

It is a further requirement that the said equipment be maintained by the Contractor, that he instructs and trains the employees in the use of the equipment and ensures that the prescribed equipment is used by the employee/s.

Employees do not have the right to refuse to use/wear the equipment prescribed by the employer and, if it is impossible for an employee to use or wear prescribed protective equipment through health or any other reason, the employee cannot be allowed to continue working under the hazardous condition/s for which the equipment was prescribed but an alternative solution has to be found that may include relocating or discharging the employee.

The Contractor may not charge any fee for protective equipment prescribed by him/her except under the following conditions:

- Where the employee requests additional issue in excess of what is prescribed
- Where the employee has patently abused or neglected the equipment leading to early failure
- Where it is proven that the employee has lost the equipment

All employees shall, as a minimum, be required to wear the following PPE on any Rehabilitation projects:

- Protective overalls
- Protective footwear
- Protective headwear
- Eye/face protection

All PPE provided to local labour working on the Expanded Public Works Programme shall be branded in accordance with the EPWP CI Manual. Typical elements which shall be branded include:

- Protective overalls
- Reflective vests
- Protective headwear

The rate for local labour shall include for the supply of EPWP branded PPE in accordance with the Provincial EPWP specifications. The rate shall include the additional cost of the specified colours for the PPE and branding in accordance with CI manual.

#### F5. EPWP BRANDING SPECIFICATION

### EPWP Branding

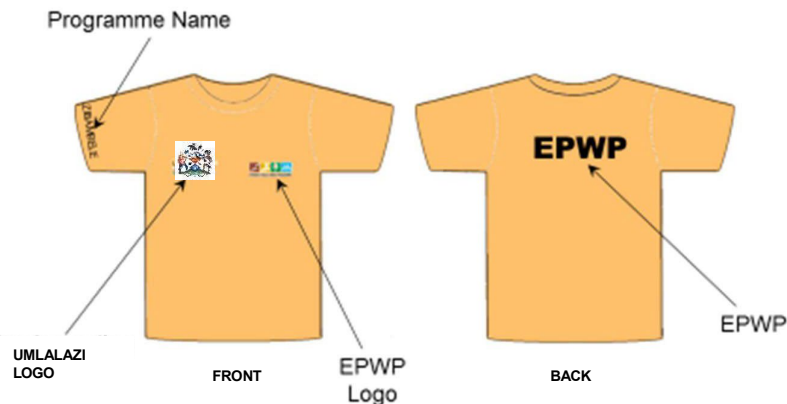

Printing on PPE: PPE (Overalls) shall be orange with/without reflective tape and shall be branded as follows:

- EPWP logo (printed or embroidered) on the left front pocket location i.e. over the heart position (full colour).
- The height of the departmental logo (including text) shall not exceed the height of the EPWP logo (including text).
- The letters EPWP on the back of the PPE in BLACK.
- The program name eg CONSTRUCTION OF HIMEVILLE ASPHALT SURFACING ROADS (PHASE 3) is to be printed on the left sleeve of short sleeved apparel and may not have to be placed on long sleeved apparel.
- Where required orange safety vests are to be branded with similar specification above. In this instance the Overalls may not necessarily be branded provided that the works never allow for labour to work without high visibility vests.
- All artwork and PPE samples shall be approved and signed off by the consultant prior to printing/embroidering.

□  
**F6. MEASUREMENT AND PAYMENT**

The following payment items shall be used to effect the payments for EPWP.

**Item Unit**

**F6.01 Payments associated with the EPWP programme:**

- (a) COIDA payments to the Compensation Commissioner for EPWP workers Prov Sum
- (b) Provision for specified EPWP branding on PPE for EPWP workers Prov Sum
- (c) Additional supervision during practical training L/Sum

The provisional sums provided under subitems F6.01(a) and (b) shall be expended in accordance with Clause 6.6 of the General Conditions of Contract 2015.

The provisional sum under subitem F6.01(a) shall be used to cover the cost of the COIDA payments made by the Contractor to the Compensation Commissioner for EPWP workers, all as authorised by the Employer's Agent.

No payment shall be made for time spent during any other on-site liaison, telephonic liaison, e-mail or written correspondence liaison between these parties, or for liaison conducted with the training service provider by any other member of the Contractor's site staff or head office personnel, the cost of all of which shall be deemed to be included in the Contractor's time-related obligations under subitem B13.01(c).

The provisional sum under subitem F6.01(b) shall be used to cover all costs associated with the provision of the necessary EPWP branded PPE including safety apparel for the EPWP workers as determined in the risk assessments and as required for full duration of the contract. See F5. EPWP BRANDING SPECIFICATION.

The lump sum tendered under subitem F6.01(c) shall include full compensation for the provision of additional supervisory staff to manage the output generated from the learners during practical training.

The Contractor shall note that no direct payment will be made to cover the Contractor's costs associated with implementing the on-site work programme for the EPWP employees, for planning, organising, directing, controlling and administrating their day to day activities, including the setting of daily tasks, record keeping and any on-site liaison, training and mentoring required, and for the associated job creation reporting, and such costs shall therefore be built into the other rates tendered for the various items of work scheduled throughout the Schedule of Quantities.

**F6.02 Provision for training of EPWP workers:**

- (a) Generic skills training L/Sum
- (b) Handling costs and profit in respect of subitem F6.02(a) above %
- (c) Training venue facility (only if required) L/Sum
- (d) Transport and accommodation of workers for training where it is not possible to undertake the training in close proximity to the site L/Sum

The lump sum under subitem F6.02(a) are provided to cover the actual costs of the training (including wages, COIDA, UIF, tools and branded PPE) for attendance of accredited training courses as agreed with the engineer and shall be expended in accordance with the provisions of sub-clause 48(2) of the general conditions of contract. The wages paid during the classroom training must be the minimum EPWP wage rate.

The tendered percentage under subitem F6.02(b) is a percentage of the amount actually spent under subitem F6.02(a) which shall include full compensation for the contractor's handling cost, profit, mentoring, record keeping, reporting and all other costs in connection therewith.

The lump sum tendered for under subitem F6.02(c) shall include full compensation for the provision of the training venue, for all necessary lighting, power, furniture, stationery, consumables and study material and for transportation of the students to and from the training venue. Payment of the lump sum will be made in two instalments as follows:

(i) The first instalment, 75% of the lump sum, will be paid after the contractor has met all his obligations regarding the provision of the training venue as specified.

(ii) The second and final instalment, 25% of the lump sum, will be paid after the provision of all the accredited training as specified in the document.

The lump sum tendered under subitem F6.02(d) shall include full compensation for the provision of transport and accommodation of workers for training where it is not possible to undertake the training in close proximity to the site.

**EXPANDED PUBLIC WORKS PROGRAMME  
EMPLOYEE CONTRACT**

**1. THE PARTIES**

This agreement is made between

The Employer .....

Represented by ..... and

The Employee .....

Employee Identity Number: .....

Gender: Male or Female ..... Age: .....

1.1. *This contract must be read in conjunction with the Basic Conditions of Employment as well as the Ministerial Determination 4: Expanded Public Works Programme.*

1.2. *The Employer hereby appoints the Employee to work on the project:*

EPWP Project No: .....

Project Name: .....

1.3. *The Employee is appointed as a..... and will be paid by the Employer: R\_\_\_\_\_ for every day task properly completed to the satisfaction of the Employer.*

1.4. *The Employee shall be paid by \_\_\_\_\_ for day tasks completed properly between \_\_\_\_\_ and \_\_\_\_\_.*

**2. OBLIGATIONS OF EMPLOYEE**

2.1. The Employee is required to carry out the work assigned by the Employer/his representative carefully, properly and within the required time for the tasks assigned, and will only be paid for completed day tasks and not on a daily wage;

2.2. The Employee is required to abide by the decisions of the Employer at all time; and

2.3. Notwithstanding the date of signature of this contract the employment relationship is deemed to have commenced on \_\_\_\_\_ and shall continue until the completion of this contract \_\_\_\_\_ OR OTHERWISE STATED.

**3. POOR WORKMANSHIP**

3.1. Should the quality of the work produced by the Employee be considered to be poor by the Employer/representative, then the Employer will not pay the Employee for the work done until the Employee has completed the work to his/her satisfaction.

**4. OBLIGATIONS OF THE EMPLOYER**

4.1. The Employer shall pay the Employee for all work assigned to the Employee which is completed satisfactorily and shall provide the Employee with the necessary tools, materials and training for the Employee to carry out the assigned work.

**5. TERMINATION OF CONTRACT**

5.1. The employer may terminate the employment of an Employee for good cause after following a fair procedure.

5.2. The Employer may terminate this agreement at its sole discretion in the following circumstances:

- a) If funding for the project is stopped for whatever reason;
- b) If the Employee continues to provide poor workmanship after being issued on warning in writing to rectify poor workmanship;
- c) If the Employee refuses to carry out the work assigned by the Employer/representative;
- d) If the Employee is drunk or disorderly or troublesome at work on the project;
- e) If the Employee is found to have stolen tools or materials from the project;
- f) If the Employee is absent from work without permission or good reason for more than three successive days.
- g) If an Employee does not attend required training events, without good reason.

5.3. A worker will not receive severance pay upon termination.

**6. SETTLING OF DISPUTES**

- 6.1. Any dispute or claim arising out of this agreement, which cannot be settled between the parties, shall be referred, without legal representation, to the Project Programme Manager for resolution. The Project Programme Manager shall investigate the dispute and shall decide fairly on the matter. The parties shall comply with the decision of the Programme Manager with respect to settlement of the dispute. Should either party fail to comply with the decision of the Programme Manager, the Programme Manager may take whatever measures he/she considers necessary to enforce compliance, including inter alia withholding further funding to the project until such time as compliance has occurred.

## 7. MEAL BREAKS

- 7.1. An Employee may not work for more than five hours without taking a meal break of at least thirty minutes duration.
- 7.2. An employer and Employee may agree on longer meal breaks.
- 7.3. An Employee may not work during a meal break. However, an employer may require an Employee to perform duties during a meal break if those duties cannot be left unattended and cannot be performed by another Employee. An employer must take reasonable steps to ensure that an Employee is relieved of his or her duties during the meal break.
- 7.4. An Employee is not entitled to payment for the period of a meal break. However, an Employee who is paid on the basis of time worked must be paid if the Employee is required to work or to be available for work during the meal break.

## 8. DAILY REST PERIOD

Every Employee is entitled to a daily rest period of at least twelve consecutive hours. The daily rest period is measured from the time the Employee ends work on the day until the time the Employee starts work on the next day.

## 9. WEEKLY REST PERIOD

Every Employee must have two days off every week. An Employee may only work on their day off to perform work which must be done without delay and cannot be performed by Employees during their ordinary hours of work ("emergency work").

## 10. KEEPING RECORDS

- 10.1. The Employee must provide to the Employer the following:
  - 10.1.1. Certified copy of ID
  - 10.1.2. Signed contract
  - 10.1.3. Standard ID picture
  - 10.1.4. Banking details corresponding to the details on the ID document

## 11. PAYMENT

- 11.1. Wages paid to the Employee will be deposited into the Employee's bank account. Cash payments will not be made.
- 11.2. The Employee will only be paid for tasks that have been completed.
- 11.3. The Employee will be paid within five weeks of the work being completed and the work having been approved by the manager.
- 11.4. An Employee will be entitled to payment only if he/she completes the assigned task to the satisfaction of the employer's site representative.
- 11.5. Employees given due notice of inclement weather will not be paid.
- 11.6. Employees will be paid if inclement weather forces work to stop while on site.
- 11.7. The Employee will be provided with the following information in writing –
  - 11.7.1. The period for which payment is made;
  - 11.7.2. The numbers of tasks completed or hours worked;
  - 11.7.3. The Employee's earnings;
  - 11.7.4. Any money deducted from the payment;
  - 11.7.5. The actual amount paid to the Employee.
- 11.8. The quantity of task rate will vary from depending on the type of activity to be performed. The Employee will be informed at the beginning of each task or group of tasks how much to be completed as a daily task work (individual or group of tasks).



- 11.9. If an Employee's employment is terminated, the employer must pay all monies owing to that Employee within one month of the termination of employment.

## 12. TRAINING

- 12.1. The Employee will be provided with training relevant to the work that will be undertaken by the Employee. The Employee commits to:
- 12.1.1. Provide the training provider with true and accurate information
  - 12.1.2. Attend all training sessions provided
  - 12.1.3. Behave in a manner conducive to training and in consideration of other learners
  - 12.1.4. Maintain learning materials and equipment issued
  - 12.1.5. Follow instructions issued by the training service provider
  - 12.1.6. Follow disciplinary procedures of the Employer and the training provider
- 12.2. The Employee will be paid R 83.59 per day of classroom training.
- 12.3. The Employee will be paid R 100.00 per day of practical training.

## 13. DEDUCTIONS

- 13.1. An employer may not deduct money from an Employee's payment unless the deduction is required in terms of a law.
- 13.2. An employer must deduct and pay to the SA Revenue Services any income tax that the Employee is required to pay.
- 13.3. An employer who deducts money from an Employee's pay for payment to another person must pay the money to that person within the time period and other requirements specified in the agreement law, court order or arbitration award concerned.
- 13.4. An employer may not require or allow an Employee to
- 13.4.1. Repay any payment except an overpayment previously made by the employer by mistake;
  - 13.4.2. State that the Employee received a greater amount of money than the employer actually paid to the Employee; or
  - 13.4.3. Pay the employer any other person for having been employed.

## 14. HEALTH AND SAFETY

- 14.1. The employer will take all reasonable steps to ensure that the working environment is healthy and safe.
- 14.2. An Employee must:
- 14.2.1. Work in a way that does not endanger his/her health and safety or that of any other person;
  - 14.2.2. Obey any health and safety instruction;
  - 14.2.3. Obey all health and safety rules of the EPWP;
  - 14.2.4. Use any personal protective equipment or clothing issued by the employer;
  - 14.2.5. Report any accident, near-miss incident or dangerous behaviour by another person to their employer or manager.

## 15. COMPENSATION FOR INJURIES AND DISEASES

- 15.1. It is the responsibility of the employer to arrange for all persons employed on EPWP to be covered in terms of the Compensation for Occupational Injuries and Diseases Act, 130 of 1993.
- 15.2. An Employee must report any work-related injury or occupational disease to the employer or designated representative.
- 15.3. The employer must report the accident or disease to the Compensation Commissioner.
- 15.4. The employer will pay an Employee who is unable to work because of any injury caused by an accident at work 75% of their earnings for up to three months. The employer will be refunded this amount by the Compensation Commissioner. This does NOT apply to injuries caused by accidents outside the workplace such as road accidents or accidents at home.

## 16. CERTIFICATE OF SERVICE

- 16.1. On termination of employment, an Employee is entitled to a certificate stating:
- 16.1.1. The Employee's full name;
  - 16.1.2. The name and address of the employer;
  - 16.1.3. The EPWP on which the Employee worked;

- 16.1.4. The work performed by the Employee;
- 16.1.5. Any training received by the Employee as part of the EPWP;
- 16.1.6. Any other information agreed on by the employer and Employee.

In addition to the above conditions all the terms and conditions of employment on EPWP and the Basic Conditions of Employment apply to your employment as well. If you are found in breach of any of these terms your contract may be terminated.

**17. SIGNATURES**

Signed on this day ..... of .....

Employer: ..... Date: .....

Employee: ..... Date: .....

Witness: ..... Date: .....

**Annexure A: Form - Participant Details**

Participant details must be filled out and attached to contract with certified copy of ID  
 This form must be used to complete the latest EPWP reporting template obtained from the Employer.

Field	Response																																								
First Name on certified ID document																																									
Initials on certified ID document																																									
Surname on certified ID document																																									
ID number on certified ID document																																									
Date Of Birth on certified ID document																																									
Gender (Mark with X)	M	F																																							
Disability (Mark with X)	Y	N																																							
Highest level of education	<table border="1"> <thead> <tr> <th>Code</th> <th>Education Levels</th> <th>Mark with X</th> </tr> </thead> <tbody> <tr><td>1</td><td>Unknown</td><td></td></tr> <tr><td>2</td><td>No Schooling</td><td></td></tr> <tr><td>3</td><td>Grade 1-3 (Sub A_ Std 1)</td><td></td></tr> <tr><td>4</td><td>Grade 4 (Std 2) Abet 1</td><td></td></tr> <tr><td>5</td><td>Grade 5-6 (Std 3-4) Abet 2</td><td></td></tr> <tr><td>6</td><td>Grade 7-8( Std) 5-6 Abet 3</td><td></td></tr> <tr><td>7</td><td>Grade 9 Abet 4</td><td></td></tr> <tr><td>8</td><td>Grade 10-11 (Std 8-9)</td><td></td></tr> <tr><td>9</td><td>Grade 12 (Std 12)</td><td></td></tr> <tr><td>10</td><td>Post Matric</td><td></td></tr> </tbody> </table>		Code	Education Levels	Mark with X	1	Unknown		2	No Schooling		3	Grade 1-3 (Sub A_ Std 1)		4	Grade 4 (Std 2) Abet 1		5	Grade 5-6 (Std 3-4) Abet 2		6	Grade 7-8( Std) 5-6 Abet 3		7	Grade 9 Abet 4		8	Grade 10-11 (Std 8-9)		9	Grade 12 (Std 12)		10	Post Matric							
	Code	Education Levels	Mark with X																																						
	1	Unknown																																							
	2	No Schooling																																							
	3	Grade 1-3 (Sub A_ Std 1)																																							
	4	Grade 4 (Std 2) Abet 1																																							
	5	Grade 5-6 (Std 3-4) Abet 2																																							
	6	Grade 7-8( Std) 5-6 Abet 3																																							
	7	Grade 9 Abet 4																																							
	8	Grade 10-11 (Std 8-9)																																							
	9	Grade 12 (Std 12)																																							
10	Post Matric																																								
Date work starts																																									
Date work ends																																									
Mark up to 3 languages spoken (Mark with X)	<table border="1"> <thead> <tr> <th>Code</th> <th>Language ID</th> <th>Mark with X</th> </tr> </thead> <tbody> <tr><td>1</td><td>Afrikaans</td><td></td></tr> <tr><td>2</td><td>English</td><td></td></tr> <tr><td>3</td><td>IsiNdebele</td><td></td></tr> <tr><td>4</td><td>IsiXhosa</td><td></td></tr> <tr><td>5</td><td>IsiZulu</td><td></td></tr> <tr><td>6</td><td>Sesotho sa Leboa</td><td></td></tr> <tr><td>7</td><td>Sesotho</td><td></td></tr> <tr><td>8</td><td>Setswana</td><td></td></tr> <tr><td>9</td><td>siSwati</td><td></td></tr> <tr><td>10</td><td>Tshivenda</td><td></td></tr> <tr><td>11</td><td>Xitsonga</td><td></td></tr> <tr><td>12</td><td>Other</td><td></td></tr> </tbody> </table>		Code	Language ID	Mark with X	1	Afrikaans		2	English		3	IsiNdebele		4	IsiXhosa		5	IsiZulu		6	Sesotho sa Leboa		7	Sesotho		8	Setswana		9	siSwati		10	Tshivenda		11	Xitsonga		12	Other	
	Code	Language ID	Mark with X																																						
	1	Afrikaans																																							
	2	English																																							
	3	IsiNdebele																																							
	4	IsiXhosa																																							
	5	IsiZulu																																							
	6	Sesotho sa Leboa																																							
	7	Sesotho																																							
	8	Setswana																																							
	9	siSwati																																							
	10	Tshivenda																																							
11	Xitsonga																																								
12	Other																																								
Address																																									
Contact Number																																									
Government Grant (Mark with X)	Y	N																																							
		Social																																							
		Disability																																							
		Child																																							
Province – completed by official																																									
District Municipality– completed by official																																									
Local Municipality – completed by official																																									

The contractor must note the target local labour area and provide preference to participants in close proximity to the project		
Nationality	RSA	Non-RSA
If non-RSA, provide details		
Work Permit number		
Country of origin		
Number of people in Household		
Number of Dependents in Household		
Number of Children attending school		

## **PART G: SMALL CONTRACTOR DEVELOPMENT**

### **G1001 SCOPE**

This section covers construction aspects relating to the processes by which the construction industry develops emerging small contractors.

In terms of this contract, the Contractor shall effect such development by subcontracting portions of the Works to Targeted Enterprises (as defined in clause G1002(a) below) such that the combined accumulated monetary value of the work undertaken and achieved by such Targeted Enterprises equals or exceeds the monetary value of the target set by the Employer for such work.

### **G1002 DEFINITIONS AND APPLICABLE LEGISLATION**

#### **(a) Definitions**

Unless inconsistent with the context, in these specifications the following terms, words or expressions shall have the meanings hereby assigned to them:

##### Contract Participation

Contract Participation in terms of this contract is a process by which the Employer implements Government's objectives by setting a target relating to small contractor development which the Contractor shall achieve as a minimum.

##### Contract Participation Goal (CPG)

Contract Participation Goal is the monetary value of the target set by the Employer in the Contract Participation process.

##### Contract Participation Performance (CPP)

Contract Participation Performance is the measure of the Contractor's progress in achieving the CPG.

##### Project Management Team (PMT)

A team established at the commencement of the contract, comprising a representative from each of the Employer, the Employer's Agent and the Contractor, that will be responsible for various functions related to the implementation of the Contract Participation process.

##### Targeted Enterprise

A Targeted Enterprise is any company engaged by the Contractor as a subcontractor and which is registered with the Construction Industry Development Board (CIDB) in a contractor grading designation equal to 1CE or 2CE or 3CE or 4CE or 5CE or 6CE and which is also registered by the CIDB as Potentially Emerging (PE).

The CPG scope in terms of Part G of this contract has been reserved for execution using only the following prescribed numbers of Targeted Enterprises registered with the CIDB in each of the contractor grading designations indicated:

- Grade 1CE PE (5 x Targeted Enterprise subcontractors prescribed)
- Grade 2CE PE (4 x Targeted Enterprise subcontractors prescribed)
- Grade 3CE PE (3 x Targeted Enterprise subcontractors prescribed)
- Grade 4CE PE (2 x Targeted Enterprise subcontractors prescribed)
- Grade 5CE PE (1 x Targeted Enterprise subcontractors prescribed)

#### **(b) Applicable Legislation**

The following Acts, as amended from time to time, are predominant amongst those which apply to the construction industry and are listed here for reference purposes only:

- The Constitution of South Africa;
- Public Finance Management Act No. 1 of 1999;

- Preferential Procurement Policy Framework Act No. 5 of 2000;
- Construction Industry Development Board Act No. 38 of 2000;
- Broad-Based Black Economic Empowerment Act No. 53 of 2003.

### **G1003 CONTRACT PARTICIPATION**

#### **(a) Objective**

Government's objective for this contract in terms of its broad-based black economic empowerment initiatives is to develop emerging small contractors that qualify as Targeted Enterprises as defined above.

#### **(b) Contract Participation Targets**

Contract participation is the process by which the Employer Implements Government's objectives. The Employer sets a target for construction by specified entities, the rand value of which is based on the services and work undertaken by the specified entities. The target rand value will be measured as that specified target percentage of the Contractor's final certified value of work completed (excluding CPA and VAT) measured at the date of issue of the Certificate of Completion. The Contractor is obliged to commit to or exceed the target stated in section C1.2.2 Contract Data, Part A: Data Provided by the Employer.

#### **(c) Contract Participation Goal (CPG)**

The CPG is the monetary value of the target set by the Employer and will be calculated as follows:

CPG = final contract value (excluding CPA and VAT) x (target % set by the Employer for Targeted Enterprises)

The final contract value is the total value of certified work measured at the date of issue of the Certificate of Completion.

The value of the Provisional Sums scheduled under item G10.02 of Part G of the schedule of quantities shall not necessarily make up the full value of the works required to meet the CPG target set by the Employer. It is the Contractor's responsibility to assess the work required to meet the CPG target and, if necessary, to engage Targeted Enterprises to execute work on the main contract as well to ensure that the CPG target is achieved.

#### **(d) Contract Participation Performance (CPP)**

The CPP is the monetary value of the Contractor's actual progress towards achievement of the CPG calculated as follows:

CPP = total value (excluding CPA and VAT) of contribution by Targeted Enterprises

The Contractor's Contract Participation Performance will be measured monthly in order to monitor the extent to which he is striving to reach the CPG. The basis of monitoring shall be the levels of the individual contributions for Targeted Enterprises. Monthly returns, in a format approved by the Employer, are required from the Contractor and shall be submitted with each interim payment certificate. Failure to adhere to this requirement shall result in the delay of any payment due until the Employer's Agent confirms that the information has been received.

To assist in the measurement of CPP, the Contractor shall include in his contract programme details of how he will achieve the CPG. This shall include CPG achievement details for both the specific work indicated for CPG in terms of this contract for completion by Targeted Enterprises as well as details for any other work that the Contractor may use towards achieving the CPG. The detail shall be provided not later than one month after the Employer's Agent has accepted the original construction programme and shall be updated with every subsequent revision of the programme.

If the Contractor fails to substantiate that any failure to achieve the Contract Participation Goal (CPG) is due to quantitative under runs, the elimination of items contracted to Targeted Enterprises, or any other reason beyond the Contractor's control which may be acceptable to the Employer, the Contractor shall be liable for a penalty as prescribed in clause SCC 4.1.1 of section C1.2.1.2 Special Conditions of Contract. The penalty shall be calculated as follows:

Penalty = 5% of the monetary value by which the achieved monetary value (CPP) falls short of the target monetary value (CPG)  
= 5% of (CPG – CPP)

The penalty shall be applied on a pro rata basis according to a monthly evaluation of achievements against the programmed utilisation.

**(e) Accredited Registration**

CPP for Targeted Enterprises shall only be accepted if the respective Targeted Enterprises for which services or work is being claimed as having been performed are registered with the CIDB in one of the defined categories. In addition, documentary evidence that such Targeted Enterprises are registered with the South African Revenue Services (SARS) shall be lodged with the Employer's Agent before the work or service may be considered as having been performed by a Targeted Enterprise. The responsibility for producing evidence of such registration documentation shall rest with the Contractor.

**(f) Record keeping and Portfolio of Evidence**

The Contractor shall assume responsibility for the compilation and maintenance of comprehensive records detailing each Targeted Enterprise's progress during construction, starting from the award of a subcontract to a Targeted Enterprise until the successful completion of the subcontract work or termination of the subcontract.

The Contractor shall keep comprehensive records of the training given to each trainee and, at the successful completion of each training course, each trainee shall be issued with a certificate indicating the course content as proof of attendance and completion. The Contractor shall keep a register of certificates issued. Whenever required, the Contractor shall provide copies of such records to the Employer's Agent.

The Contractor is also required to develop and/or maintain a portfolio of evidence for each Targeted Enterprise as described in clause G1009.8 below.

**G1004 TENDER PROCESS FOR TARGETED ENTERPRISE SUBCONTRACTOR PROCUREMENT**

The Contractor shall refer to the schedule of quantities contained in these Particular Specifications and to any other construction activities required to execute the Works in terms of this contract to determine how he intends to unbundle or package specific subcontracts for Targeted Enterprises and shall present his proposal to the PMT for approval.

The Contractor shall be responsible for compiling the tender documents that will enable him to engage the Targeted Enterprises.

In compiling the subcontract tender documents, the Contractor shall also include in each tender document any Tender Rules that may be relevant, and shall also include the proposed subcontract agreement. The Contractor shall compile each subcontract tender document in such a manner that it shall facilitate the achievement of all objectives and principles pertaining to the development of the Targeted Enterprises.

Draft tender documents shall be approved by the PMT before the Contractor invites tenders from Targeted Enterprises, who will be invited in consultation with the PMT and the local PLC.

The PMT shall conduct a compulsory briefing session to explain the Works required and the tender process to the Targeted Enterprises.

Tenders for the subcontracted works must close at a stipulated time and date. Tenders shall be placed in a suitable formal Tender Box of design approved by the PMT, located at the Contractor's site office. The tender opening shall be conducted by the PMT.

The Contractor shall evaluate the tenders and shall submit the tender adjudication report for each subcontract to the PMT for review prior to award of each subcontract.

It shall be a condition of tender that the subcontractors appointed as Targeted Enterprises are registered with the Construction Industry Development Board (CIDB) in a contractor grading designation equal to 1CE or 2CE or 3CE or 4CE or 5CE or 6CE and are also registered by the CIDB as Potentially Emerging (PE).

It shall also be a condition of tender that Targeted Enterprises shall include in their tender submission the following documentation:

1. Valid letter of good standing from the Department of Labour.
2. A tax compliance status report.
3. A BEE verification certificate
4. Bank account details certified by the bank.
5. Certificate of registration of the tenderer in the required CIDB contractor grading designation, confirming the tenderer's registration Status as "Active" at the closing date of tender.

The tender documents shall also contain the proposed subcontract agreement, which shall also include for:

- (a) An entitlement of the subcontractor to receive such training as is contemplated in this contract.
- (b) An obligation on the Targeted Enterprise to participate and co-operate in such training as is provided for in this contract.
- (c) The allowable sources from which workers may be drawn in terms of the contract.
- (d) The terms and conditions relating to the recruitment, employment and remuneration of workers engaged on the contract.
- (e) The training to be provided to the temporary workforce.
- (f) The terms and conditions relating to payment of the Targeted Enterprise subcontractor.

#### **G1005 PROJECT MANAGEMENT TEAM (pmt)**

##### **(a) Appointment**

A Project Management Team (PMT) is to be set up comprising a representative from each of the Employer, the Employer's Agent and the Contractor.

##### **(b) Duties and functions of the PMT**

The duties and functions of the PMT are as follows:

- (i) determine the scope and extent of the works to be included in any particular subcontract;
  - (ii) determine the target tender price according to the scope of work, and adjust the target rates where relevant;
  - (iii) monitor the management of the tender process for the subcontracts to be executed by the Targeted Enterprises;
- (iv) adjudicate and approve tenders for Targeted Enterprise subcontracts;
- (v) monitor the management of the subcontracts involving Targeted Enterprises;
- (vi) monitor the training, mentoring and development of Targeted Enterprises.

#### **G1006 general responsibilities of the contractor towards TARGETED ENTERPRISE SUB-CONTRACTORS**

##### **(a) Obligations**

The Contractor shall ensure that he complies with the following obligations:

- (i) institute a quality assurance system;
- (ii) provide adequate training, coaching, guidance, mentoring and assistance to Targeted Enterprises;
- (iii) provide financial support and other assistance to ensure that the Targeted Enterprises are able to meet their obligations and commitments with respect to their subcontracts, including acquisition of labour, equipment and materials; and
- (iv) ensure that the contract participation goals and objectives are achieved.

#### **G1007 management of targeted enterprise subcontracts**

The Contractor shall conclude the subcontract agreements, and provide the necessary management support to the Targeted Enterprise subcontractors. Failure by the subcontractor to comply with the terms and conditions of the subcontract agreement shall result in penalties being applied or the subcontract terminated.



### **G1007.1      Compilation of Subcontract conclusion agreement**

(a) The Contractor in liaison with the PMT shall be responsible for the conclusion of each subcontract agreement. The agreement shall be in accordance with the provisions of subclause 4.4 of the General Conditions of Contract for Construction Works 3<sup>rd</sup> Edition 2015 and shall be consistent with the terms and conditions in this contract. The agreement shall be subject to approval by the Project Management Team.

(b) The terms and conditions of the subcontract agreement shall also specify the following:

- (i) an entitlement of the subcontractor to receive such training as is contemplated in this contract;
- (ii) an obligation on the Targeted Enterprise to participate and co-operate in such training as is provided for in this contract;
- (iii) the allowable sources from which workers may be drawn in terms of the contract;
- (iv) the terms and conditions relating to the recruitment, employment and remuneration of workers engaged on the contract;
- (v) the training to be provided to the temporary workforce; and
- (vi) the terms and conditions relating to payment of the Targeted Enterprise subcontractor.

### **G1007.2      Quality of work and performance of the subcontractor**

(a) The Contractor shall closely monitor and supervise all Targeted Enterprises and shall train, mentor, guide and assist each Targeted Enterprise in all aspects of management, execution and completion of his subcontract. This shall typically include assistance with planning of the works, sourcing and ordering of materials, labour relations, monthly measurements and invoicing procedures. The extent and level of such training, mentoring, guidance and assistance to be provided by the Contractor shall be commensurate with the basic level of subcontract applicable and shall be directed at enabling the Targeted Enterprise to achieve the successful execution and completion of their subcontract.

(b) The Contractor shall closely monitor and supervise all Targeted Enterprises and shall give reasonable warning to the Targeted Enterprise when any contravention of the terms and conditions of the subcontract has occurred or appears likely to occur. The Contractor shall, whenever feasible, give the Targeted Enterprise reasonable opportunity to make good any such contravention, or to avoid such contravention, and shall render all reasonable assistance to the Targeted Enterprise in this regard.

### **G1007.3      Dispute avoidance and resolution procedures**

(a) When taking any disciplinary action or imposing a penalty as provided for in the subcontract, the Contractor shall explain fully to the Targeted Enterprise that such actions are provided for in the subcontract. If such action is contemplated this shall be discussed with the PMT before any action is taken.

(b) If the subcontractor, in the opinion of the Employer's Agent, fails to comply with any of the criteria listed below, the Employer's Agent shall issue a written warning to the Contractor, stating all the areas of non-compliance. A copy of the letter of warning shall be forwarded to the Employer. The criteria are as follows:

- (i) acceptable standard of work as set out in the specifications;
- (ii) progress in accordance with the time constraints in the subcontractor's tender document;
- (iii) punctual and full payment of the workforce and suppliers;
- (iv) site safety; and
- (v) accommodation of traffic.

(c) The subcontractor shall have 21 days from the date of receipt of the letter of warning by the Contractor to address and rectify the issues raised by the Employer's Agent, with the exception of the above subclauses (b)(iv) and (v) for which the reaction time shall be in accordance with the relevant specifications for those aspects of the Works but shall not be longer than 24 hours. Failure by the subcontractor to comply with deadline set, will be sufficient grounds for the Contractor to apply a penalty, or terminate the subcontract provided that the PMT is satisfied that the Contractor has made every effort to correct the performance of the subcontractor.

(d) The Targeted Enterprise shall have the right to dispute any ruling given or deemed to have been given by the Contractor, Employer's Agent or Employer. Provided that, unless the Targeted Enterprise shall, within 21 days after his receipt of a ruling or after a ruling shall have been deemed to be have been given, give written notice (hereinafter referred to as a Dispute Notice) to the Contractor, referring to this clause, disputing the

validity or correctness of the whole or a specified part of the ruling, he shall have no further right to dispute that ruling or the part thereof not disputed in the said notice.

### **G1008 specific work to be carried out by targeted enterprise subcontractors**

For this particular contract, the following listed work has been identified in terms of this Particular Specification, Part G, as suitable for execution by Targeted Enterprises in order to assist the Contractor in achieving his CPG:

1. Accommodation of Traffic
2. Clearing and grubbing.
3. Construction and clearing of drains.
4. Installation of prefabricated culverts including inlet and outlet structures.
5. Concrete channelling and concrete linings for open drains.
6. Mass Earthworks
7. Pavement Layerworks
8. Breaking up of Existing Pavement Layers
9. Surfacing
10. Pitching, stonework and protection against erosion.
11. Construction of gabions.
12. Erection of guardrails.
13. Erection of road signs.
14. Road Marking
15. Landscaping.
16. Finishing the road and road reserve.
17. Foundations for structures
18. Falsework, Formwork And Concrete Finish
19. Steel Reinforcement for Structures
20. Concrete for structures
21. No-Fines Concrete, Joints, Bearings, Bolt Groups For Electrification, Parapets And Drainage For Structures
22. Structural Steelwork
23. Patented Earth Retaining Systems
24. Testing Materials And Workmanship
25. Other work identified by the Employer to be executed in the community area.

The work to be carried out by Targeted Enterprises is not limited to the work listed above, and the Contractor may need to engage Targeted Enterprises on other aspects of the main contract work in order to achieve his CPG.

### **G1009 training, coaching, guidance and mentoring**

#### **G1009.1 Obligations**

This section provides details of the Contractor's obligations of implementing the National Skills Development Strategy. This strategy sets priorities for the skills development of workers. The Sector Education and Training Authorities (SETA) and provincial offices of the Department of Labour will play key roles in transforming the vision of the strategy into reality.

Supervision is included as part of the contractor's general obligations for the administration and management of the Targeted Enterprises. However training, coaching, guidance and mentoring are not included as part of the Contractor's general obligations unless specific provision to that effect has been made in the project specifications.

The Contractor shall, from the commencement of the contract, provide a structured development programme designed to improve the entrepreneurial and basic business management skills of identified Targeted Enterprises and hired labour that show initiative, as well as to improve their specific task skills (engineering skills) commensurate with the applicable levels of subcontract that will enable the Targeted Enterprises to achieve the successful execution and completion of their subcontracts. The ultimate objective of training, coaching, guidance and mentoring is to develop the Targeted Enterprise subcontractors as far as their potential allows.

## **G1009.2 Definitions**

### **(a) Training:**

Training refers to the process of teaching a learner – usually in a classroom or simulated work environment situation. Training usually takes place with one teacher/trainer and several learners. Principles and theory are taught. Demonstrations are given. Assignments are then set to ensure that the learner is able to apply what has been taught. Training is done by a specialist in the subject, who is also qualified to train.

Example: Use of a dumpy level

Training would involve the theory of how a dumpy level works and how to calculate levels. A demonstration of how to set up and read a level could be given.

### **(b) Coaching:**

Coaching refers to hands-on training and is mostly on a one-on-one basis of tangible and measurable skills. It is typically on-site training, or learning-on-the-job. Coaching is training by the process of “watch-do-correct-practice”. The coach does the task while the learner watches and asks questions. Then the learner does the same task while the coach watches. The learner is corrected until the coach feels that he has the gained competence in the function. The learner is then left to practise the task or skill, which the coach oversees. Coaching is imparting a skill – usually manual or physical. A coach is usually a person doing the same type of work on a higher or more competent level, or a person who has a mastery of the skill/task. While training gives the theory or shows/explains the principles, coaching helps the learner become competent and master a skill. A coach is often in the direct reporting line, i.e. someone in authority. Coaching could be part of the management function and would make the job run more smoothly.

Example: Use of a dumpy level

Coaching would involve taking the learner onto site, setting up a dumpy level, reading levels. Then the coach would get the learner to do the job, while the coach checked the setting up and reading. Once the learner understands and can do the tasks, the coach checks periodically to ensure the learner is still doing the job properly.

The desired outcome of coaching is for the learner to “fit-the-mould”, and to do things the same way and to the same standard as the coach.

### **(c) Guidance:**

Guidance is anticipating where one might go wrong, or where one is doing a task in a complicated, inefficient or ineffective way, and giving advice as to how to achieve a better result. Guidance is mostly given by a person in the direct reporting line, but can be given by anyone. Guidance is not imparting skills, but suggesting ways to improve performance.

Example: Use of a dumpy level

A person who knows how to use a dumpy level would be given guidance as to where he would next set up the level to limit the number of set-ups. Guidance could be an extension of coaching.

### **(d) Mentoring:**

Mentoring is developing a person on a long-term career path. It is mostly about imparting skills that are often intangible and non-measurable. A mentor is seldom anyone in the direct reporting line – although he could be a person several levels higher in that reporting line. Mentoring is more about developing a relationship and taking a personal interest in an individual. A mentor looks out for that individual and gives him advice that cannot be found in a book or in the normal course of business. The sort of issues a mentor discusses with the protégé include company politics, how to pick up work before others get wind of it, how to position one's company to get a better competitive advantage, how to tender such that the tender is lowest but the profit is as good as or better than the next person, how to determine and assess risk. Mentoring helps the protégé think strategically, sharpen entrepreneurial skills and grow – both personally and in terms of the company. A mentor helps the protégé to develop insight and shrewdness. It is more about business skills to survive long-term than the technical, tactical or day-to-day activities of doing business.

The desired outcome of mentoring is for the protégé to develop his own style, i.e., to shape his own “mould”.

### **(e) Supervision:**

Supervision is instruction regarding the work to be performed, and ensuring it is carried out to specification and to the satisfaction of the supervisor. It is not instruction on how the work is to be performed, but rather on what work has to be performed, and usually has specific time frames.

### **G1009.3 Assessment of Targeted Enterprise potential**

It is the responsibility of the Contractor to determine the level of development required by each Targeted Enterprise. This will require that the Contractor determine the level at which the Targeted Enterprise can operate competently and determine the skills already acquired by the Targeted Enterprise subcontractor in terms of training and on-the-job experience. In some circumstances Adult Basic Education Training (ABET) will need to be started before any formal training can commence. The assessment of each appointed Targeted Enterprise is to be produced by the Contractor for discussion at the first Project Management Team meeting following the appointment of the Targeted Enterprise.

### **G1009.4 Development Plan**

Within a month of the first PMT meeting on the Targeted Enterprise assessments, the Contractor is to present a development plan, specific to each Targeted Enterprise. The development plan is to be reviewed by the PMT for appropriateness before being implemented.

The development plan is to include the following:

- specify the development needs of each Targeted Enterprise contracting entity – the systems the entity lacks;
- specify the development needs of the individuals comprising the entity – the skills the individuals within the entity lack;
- the level to which that activity will be developed within the period of the contract;
- whether training, coaching, guidance and/or mentoring is to be given in each activity;
- the person/s responsible for each activity.

### **G1009.5 Identification and general training of potential Targeted Enterprises**

(a) The progression of training, coaching and mentorship may need to start with the identification and general training of potential Targeted Enterprises and hired labour that show initiative, and should end with their acquisition of sufficient management skills that will equip them to compete confidently for subcontract work beyond the duration of this contract. In addition, generic skills shall be taught where the need for these has been identified as being necessary amongst Targeted Enterprise workforces and hired labour.

(b) Before commencing with any structured training the Contractor shall submit his intended programme to the Project Management Team for approval of its subject content and proposed trainers, and the Contractor shall, if so instructed by the PMT, alter or amend the programme and/or course content.

The Contractor shall be responsible for the provision of everything necessary for the delivery of the various training workshops and modules including:

- (i) Provision of a suitable fully serviced training venue facility as specified in this Part G;
- (ii) Procurement of suitable accredited trainers;
- (iii) Provision, in conjunction with the accredited trainers, of all the necessary training materials, including stationery and study materials; and
- (iv) transportation of the learners to and from the training venue facility (it is therefore in the Contractor's interest that the training venue facility be provided on the site in order to reduce these transportation costs).

Payment to the Contractor for carrying out the training function shall be effected through the pay items provided in this Part G.

### **G1009.7 Activities**

The tasks for each of the activities making up the development plan are described below in further detail.

#### **G1009.7.1 Technical**

##### G1009.7.1(a) Technical Administrative Functions

### General Tasks

(i) Understanding and interpreting drawings:

On Roadwork Construction Contracts, the reading of drawings is required at high levels of Targeted Enterprise development. The relevant drawings that would need to be understood include all relevant roadwork and concrete brick wall details for construction. Understanding and interpreting drawings includes the following:

- Understanding the cross referencing to drawings from the contract documents and the bill of quantities;
- Understanding the layout of the drawings;
- Understanding the plan view and elevations and cross sections;
- How to interpret, accurately lay out and construct the details.

(ii) Setting out construction works:

This skill requires an understanding of the function and use of instruments such as the dumpy level, the theodolite, and procedures such as stringing a line.

(iii) Technical know-how of all relevant Roadwork construction activities, and typically includes:

- Traffic control/safety precautions;
- Environmental management;
- Clearing and grubbing;
- Excavations and backfilling;
- Pre-cast and in-situ cast concrete works (including reinforcing where applicable);
- Storm water channelling and catch pits / chutes;
- Mass earthworks and pavement layers;
- Asphalt paving;
- Concrete block paving;
- Concrete brick laying;
- Plastering and bag washing;
- Guardrails;
- Fencing;
- Finishing up and tidying of works.

The development plans shall maximise the exposure of each Targeted Enterprise to as many activities as is practicable.

(iv) Task organization:

This activity involves the correct supervision of labour and organisation of tasks to ensure that labour is utilised most effectively. This includes the following:

- Allocation of the appropriate number of people for the task;
- Availability on site of the correct type and amount of material and equipment at the point of use;
- Planning tasks ahead so that labour does not stand around waiting.

(v) Task prioritization:

Task prioritization must cover an understanding of critical paths, including identifying which tasks can be postponed and which are urgent. It includes planning and monitoring so that time targets are achieved. It must also cover gaining an understanding of the penalties applicable to late completion of tasks.

(vi) Work schedule:

This is the ability to produce daily work plans and will assist with task organization. Daily work plans need to be developed into weekly and monthly work plans and vice versa. These plans assist in material ordering, plant scheduling, labour allocation, timeous completion of the work, and keeping track of profits/losses.

(vii) Effectiveness:

Effectiveness is ensuring that a job gets done right, or properly.

*Effectiveness is doing the right things.*

(viii) Efficiency:

Efficiency is ensuring that the job is done with the least effort and cost possible.

*Efficiency is doing things right.*

(ix) Quality control:

Quality control requires knowledge of specifications and tolerances and ensuring that the work adheres to these, as well as understanding the requirements of the Employer.

(x) Measuring work done for payment certificates:

This is the ability to measure actual work done and to translate these measurements into a payment certificate. Knowledge must be gained of how to calculate escalation, how to claim for VOs and how to handle other claims.

(xi) Site meetings:

Knowledge needs to be gained of the following:

- The importance of site meetings;
- Identifying the relevant personnel to attend site meetings;
- Preparing for a site meeting;
- Understanding progress reports including why they are important and how to prepare them;
- Recording issues discussed at the meeting;
- Implementing and follow through of issues recorded;
- Understanding the process of the meeting and when to bring up various concerns is needed.

(xii) Handling site instructions and VOs:

This is the ability to distinguish between site instructions and variation orders and how to respond to such instructions.

#### Materials Tasks

(xiii) Materials planning:

This includes the following:

- Determining the quantity of materials required for each task and planning ordering;
- Determine appropriate lead times to ensure that everything required to do a job is on hand;
- Quantity take-offs for pricing a bill at higher levels of development.

(xiv) Receiving, storing and handling materials:

Receiving includes checking materials delivered against the delivery note and the order placed. Storage involves knowing what quantities and type of materials to store, planning accessibility, and safety of materials from theft, the weather, etc. Handling of materials needs to be carried out to ensure no wastage or damage.

(xv) Waste control:

This includes the importance of waste control to reduce costs and the management of reducing waste of materials in storage and in use.

(xvi) The handling/installation of precast units:

Knowledge of precast units, handling and installation must be gained.

#### Equipment Tasks

(xvii) Machine Analysis:

This is the analysis of the use of equipment. It includes calculating fuel and hourly costs. This will enhance an understanding of the effective use of equipment, how to reduce costs and provide a background for pricing of equipment for tenders.

(xviii) Maintenance Schedule:

This covers the importance of maintenance of equipment and how to schedule this so that there is minimal disruption in day-to-day work.

(xix) Appropriate and correct use of tools and equipment:

Provide coaching on the correct use of tools and equipment.

(xx) Care of tools and equipment:

Care of tools and equipment includes the proper handling, cleaning, storage, stacking, etc.

The coaches of the above listed activities are generally the Foreman, Site Clerk, Mechanic, Construction Manager, Plant Manager or Contracts Manager.

G1009.7.1(b) Technical Management Functions

General Tasks

(i) Site set-up:

This involves gaining an understanding of site set-up procedures and principles, including establishing a site office and facilities, providing access to the site, initial layout of the works, storage facilities, security, etc.

(ii) Construction program / work plan:

Knowledge of how to develop a construction program / work plan, monitor and assess the production, and correct the programme where necessary.

(iii) Understanding tests:

Understanding what tests are required, reading and interpreting results relating to specifications and quality, and how to make the corrections required.

(iv) Productivity:

Recording productivity and understanding the principles. Knowing where to make corrections and how to implement solutions.

Material Tasks

(v) Materials schedule:

This involves gaining knowledge of how to develop a materials schedule from a Bill of Quantities, the Drawings and any other relevant contractual document. It also includes linking the works program to an ordering schedule, and sourcing of suitable materials.

Equipment

(vi) Determine appropriate levels of equipment:

The determination of the appropriate type and number of tools, and equipment required.

(vii) Proper use of equipment:

This is gaining knowledge, understanding and competency in the proper use of equipment.

(viii) Productivity of equipment:

The productivity of equipment must be understood to know how this affects his ability to perform.

(ix) Allocation of equipment:

This involves the ability to competently allocate equipment to the various tasks.

(x) Waste control:

Waste control is an essential aspect of running a site well and making a profit. The principles of this, together with the practical ways to control waste need to be understood.

The coach/mentor of these activities is generally the Construction Manager, Contracts Manager, or Equipment Supplier.

**G1009.7.2 Financial**

G1009.7.2(a) Financial Administrative Functions

(i) Basic Finance:

This includes knowledge of the definition and difference between debtors and creditors as well as gaining competency in basic bookkeeping. Knowledge of keeping and managing accounts and other financial documents also needs to be developed. A basic financial course may be appropriate to develop in this area.

(ii) Bank account:

The opening of a bank account, making deposits, the difference between stop-orders and debit-orders, overdraft facilities and generally managing a bank account needs to be understood. This can also be done through a course, and/or with a supportive bank manager, and/or with the appointed coach/mentor.

(iii) Orders and systems:

This will require the setting up of systems and procedures that will take into consideration delivery lead-times, non-availability of items, alternate sources, preparation of storage areas ready for delivery, and the area/volume of storage space.

(iv) Invoices:

The development of systems within the Targeted Enterprise entity that will check materials received versus what was ordered, check quantities delivered, and check actual prices paid against quotes/tender prices.

(v) Stock Control:

The importance of controlling stock needs to be understood. Systems to implement stock control need to be imparted.

(vi) Payroll:

This involves the establishment of a payroll system within the Targeted Enterprise entity. This could include developing an internal system, outsourcing the payroll or learning a commercially acquired payroll system. The system needs to record days worked, pay rate, legal deductions and a leave register.

(vii) Legal requirements:

The financial requirements of legal obligations of companies must be imparted to the Targeted Enterprise subcontractor. This includes payment of company tax, VAT (Value Added Tax), Skills Development Levy (SDL), Work Unemployment Insurance Fund (UIF), Workman's' Compensation (WC), and any applicable municipal levies as well as the applicable minimum wages for the area (also refer below to G1009.7.5 Legislative).

(viii) Payment certificates:

This includes the compilation and submission of a payment certificate. As well as knowing how to determine work done to date, how to present it in terms of the Bill of Quantities, and how to claim for materials on site.

G1009.7.2(b) Financial Management Functions

(i) Claims and VOs:

The following types of claims may be applicable: Claims for additional work done, inclement weather, etc., claims for Variation Orders implemented. Understanding claims includes knowing when a claim can be submitted, the procedure and paperwork for the submission of a claim and which claims are worth pursuing.

(ii) Cash Flow:

The concept of cash flow, as well as the development of cash flow projections and the monitoring of the cash flow are vital aspects of running a business. Included under this topic is knowing how long it takes from placing an order for material until payment is due, and time lags between ordering materials and using the materials and receiving payment for work done. The concept of sufficient working capital also needs to be imparted.

(iii) Costing System:

Costing systems must be set up and understood. Aspects include capturing costs, monitoring profit, analysing costs and using this information to determine productivity levels.

(iv) Tendering:

A knowledge is required of how to build up rates, how to obtain prices, how to negotiate better discounts, how to be creative to achieve the desired result more cost effectively, how to calculate and accommodate P&Gs, and what Provisional Sums are and how they are handled.

(v) Budgeting:

The difference between tendering and budgeting must be understood as well as gaining skills on how to develop a budget. Knowledge of how to monitor actual expenses against budgeted expenses, how to analyse the differences, and the value budgeting is needed.

(vi) Risk assessment:

This involves learning how to assess the financial risks associated with the job in terms of his performance and profitability and the management of these risks. This becomes increasingly important as the Targeted Enterprise grows.

(vii) Insurance:



This includes an understanding of why insurance is required, how to obtain insurance, the benefits and costs, insurance providers and what can be claimed from different types of insurance. The different types of insurance to be included are Short term insurance, Public Liability and Contractors All Risk insurance.

(viii) Interest Rates:

Interest Rates can have a dramatic impact on the profit margins. Therefore an understanding must be gained of what interest rates are, how they impact on profit margins, how to cater for fluctuating interest rates in preparing a tender, and how to find and/or negotiate the best interest rates.

(ix) Bridging Finance:

This includes understanding what bridging finance is and the different forms of bridging finance. Guidance should be given on when bridging finance should be used, where it can be obtained, what securities are needed, and how to go about securing funds.

(x) Sureties:

This involves understanding what Sureties are, why and when they are needed, how they can be obtained, what they cost and how they can be redeemed.

(xi) Procurement of Plant and Equipment:

The difference between purchasing, leasing, hire purchase and hiring plant needs to be understood. Also included is gaining knowledge of all aspects of these options as well as the benefits and implications for the business for each option.

(xii) Procurement:

Procurement of materials includes sourcing suppliers, getting quotes, placing an order and negotiating discounts. The managing contractor can assist in introducing higher level Targeted Enterprises to the relevant materials suppliers.

(xiii) Subcontract:

At the lower levels, this will involve the Targeted Enterprise understanding the subcontract agreement between himself and the managing contractor and the obligations of this document. With a Targeted Enterprise operating at a higher level, this will include sourcing other subcontractors, as well as interpreting the tender/quote, adjudication and awarding of subcontracts.

(xiv) Productivity:

This includes taking production rates and translating them into financial terms to help build up rates for tendering and to monitor profit margins.

The coach and/or mentor for these functions are typically the Bookkeeper, Site Clerk, Foreman, Construction Manager, Contracts Manager, Accountant, Estimator and Buyer.

### **G1009.7.3 Human Resources**

#### **G1009.7.3.(a) Human Resource Administrative Functions**

(i) Labour Supervision:

This involves the supervising of labour effectively. This includes knowing the level of competencies of labour, being able to motivate workers to ensure that productivity levels are achieved and maintained. It also includes the allocation of tasks to labour.

(ii) Team Sizes:

This is ensuring the size of the work team is appropriate for the matching activity and understanding that teams that are too large are unproductive and teams that are too small are not effective.

(iii) Productivity:

The principles of productivity and how it is best achieved for various tasks is to be understood and applied. It also involves being able to determine realistic productivity levels, such as square metres of grass cut with a machine per hour, length of guardrail installed per day, etc.

(iv) Time sheet:

A system of time sheets which accurately records the time each employee spends on the job needs to be in place.

(v) Leave Registers:

A system for recording leave needs to be in place, which includes the dates that leave was taken, what type of leave it was and whether the employee qualifies for paid or unpaid leave in terms of legislation.

(vi) Employee records:

This involves knowing and complying with legislation for conditions of employment. Employment contracts must be in place for all labour employed and a formal system of keeping employee records must be established. Employee records must be in line with legislation including recording of employee details and copies of identification documents, termination of service procedures, certificates of service etc.

(vii) Disciplinary procedure:

Knowledge of the legal aspects of Disciplinary procedures is essential. The ability to set up these procedures, and ensure that all staff understand and adhere to them is required. Warning systems must include records of verbal warnings, warning forms, disciplinary hearings, dispute resolutions and termination procedures.

(viii) Training:

This involves understanding the concept of the Skills Development Levy, and how to claim from CETA for training provided. Service Providers have CETA funded Skills Facilitators available to assist Targeted Enterprises in identifying training needs and compiling work place skills plans (WPSP) at no cost to the Targeted Enterprise. An understanding of the importance of providing training for staff with regards to AIDS awareness, Safety, Productivity, Development and Accountability is essential.

(ix) Community Liaison:

The management and importance of Community Liaison must be understood.

G1009.7.3(b) Human Resource Management Functions

(i) Labour recruitment:

Employment of labour with the appropriate skills is essential. Therefore sourcing of appropriate labour and knowledge of how to assess the range of skills and level of competency in potential employees needs to be gained.

(ii) Labour allocation:

Allocation of labour is a skill that needs continual refining. It requires knowing the specific strengths of staff employed, the numbers of labourers and level of skill required for specific tasks, as well as being able to build effective cohesive teams that understand their roles without continual supervision.

(iii) Labour schedules / planning:

This involves learning how to compile labour schedules from the works program and the consequent allocation of staff to the work planned.

(iv) Histogram / manpower plan:

A manpower plan includes establishing how many people are needed on the job at what times. This is an important skill even at the most elementary level. As the Targeted Enterprise develops, the management of moving people from site to site in such a way that there are neither too many nor too few labourers and/or supervision becomes an important skill to obtain.

(v) Management of supervision:

This activity involves understanding the principles of supervision, and how to effectively manage to ensure that these principles are applied and/or developed by the appointed supervisor.

(vi) Productivity:

Productivity applies to labour as well as tasks and plant. Skills must be developed on how to determine appropriate levels of labour productivity and how to ensure that staff achieves these levels.

(vii) Labour Law:

A basic understanding of labour legislation, specifically Labour Relations Act (LRA), and Basic Conditions of Employment Act (BCEA), Employment Contracts, and Termination of Service is essential as well as an understanding of the implications of these laws on business.

(viii) Accountability systems:

This requires that accountability systems are developed and implemented for supervisory staff.

Coaching, guidance and mentoring on the above listed functions are typically undertaken by the Foreman, Construction Manager, Site Clerk, HR Manager, Trainer and Contracts Manager.

#### **G1009.7.4 Contractual**

##### G1009.7.4(a) Contractual Administrative Functions

(i) Relationships and communication:

This involves the development and maintenance of good relationships and the establishment of good communication systems within the Targeted Enterprise business. This includes communication between the Targeted Enterprise and the other role players such as the Managing contractor, the Employer's Agent and the Employer. An understanding of the importance of good communication is also important. Good communication starts with the right attitude, and involves listening as well as talking. It is also listening to what is not being said. Allowances need to be made for differences in culture and economic backgrounds.

(ii) Setting up contractual administration requirement (systems):

Contractual administration systems need to be established and implemented. This includes the use and importance of site dairies and keeping rainfall/weather records, as well as developing progress reports.

(iii) Implementing EMP:

This activity involves understanding the design and implementation of an Environmental Management Plan.

##### G1009.7.4(b) Contractual Management Functions

(i) Contract Law:

Knowing and understanding the content and implications (including costs) of the Conditions of Contract and the Specifications that will be required. This will include understanding the content and implications of penalty clauses.

(ii) Risk Assessment:

This activity involves being able to assess the contractual risks associated with the contract both in terms of performance and in terms of the risks associated with the Employer.

(iii) Managing Contract Administration:

Managing Contract Administration ensures that all the required reports, such as accident reports and progress reports are completed and submitted.

(iv) Administration of subcontractors:

Identification and separation of the responsibilities of the managing contractor from the responsibilities of the subcontractors needs to be understood and applied. The management of subcontractors to ensure that contractual obligations are met is essential knowledge to be gained by higher level Targeted Enterprises.

(v) Subcontractor agreements:

Understanding the contents of the subcontract agreement between the Targeted Enterprise and the contractor is an important skill to be learnt.

(vi) Disputes:

This activity involves understanding the procedures used in handling disputes or disagreements with the Contractor and/or the Employer.

The Contracts Manager and Construction Manager would normally be involved in this function.

#### **G1009.7.5 Legislative**

##### G1009.7.5(a) Legislative Administrative Functions

(i) Legal Registrations:

The legal requirements for registration of companies must be imparted to the Targeted Enterprise subcontractor. This includes company tax, VAT (Value Added Tax), PAYE, Skills Development Levy (SDL), Unemployment Insurance Fund (UIF), Workman's' Compensation (WC), and any applicable municipal levies. An understanding of what each registration is, what benefits he gets from being registered, and how to register must be developed.

G1009.7.5(b) Legislative Management Functions

(i) Labour Law:

Knowledge of the labour legislation and the implications for the business is required. This includes Skills Development Levy (SDL), Work Place Skills Plans (WPSP), Unemployment Insurance Fund (UIF), Workman's Compensation (WC), Labour Relations Act (LRA), Basic Conditions of Employment Act (BCEA), and the applicable minimum wages for the area.

(ii) OHS Act:

All aspects of the OHS Act (dealing with safety and health) and the implications must be understood. A safety officer who has the appropriate level of understanding and knowledge must be appointed within each Targeted Enterprise.

(iii) Environmental Management Plan:

An environmental management plan needs to be submitted regarding how the environment will be managed for the duration of the contract, and what restoration will take place at the end of the contract. An understanding of the importance and content of this plan must be gained.

(iv) Adjudication/Arbitration:

This activity involves knowing what legal recourse is available when disputes/disagreements are not resolved. This knowledge must include the processes to be followed and where to go to implement proceedings.

These functions will generally require the input of the company lawyer, company accountant, HR manager, Health and Safety Specialist, and Environmental Specialist.

**G1009.7.6 General**

G1009.7.6(a) Administrative Functions

(i) Filing systems:

This activity includes establishing company filing systems that are efficient and effective. It also includes knowing the importance of filing, what must be filed and how it should be filed.

(ii) Office set-out:

Knowledge of the layout of the site office buildings position and the organisation of the offices and systems within the buildings is to be imparted.

(iii) Record keeping:

This activity involves developing knowledge of what records need to be kept and how best to keep them.

(vi) Good housekeeping:

Good housekeeping is about developing a work approach of keeping the site tidy, cleaning putting away tools and working in an orderly way. Developing good housekeeping assists a company in working efficiently and improving profit margins.

(v) Communications with staff:

The importance of good communication with staff needs to be understood as well as the effects of good relations with the staff in terms of loyalty and productivity. An understanding must also be gained that good communication enhances supervision and management of the work.

(vi) Communications on site:

This activity involves establishing communication systems between the site and the office and understanding that effective communication on site leads to good relations and contributes to the smooth running of the site.

The Construction Manager, site clerk and HR Manager will train/coach or mentor the above listed functions.

**G1009.8 Portfolio of Evidence**

The Contractor is to develop and/or maintain a portfolio of evidence for each Targeted Enterprise. The Portfolio of Evidence is a collection of proof of the training, coaching, guidance and mentoring inputs provided to the Targeted Enterprise and is similar to a log book used by technical students completing experiential training. It

is a living document which records the development progress of the Targeted Enterprise and will need to be updated continually throughout the duration of the contract. It remains the property of the Targeted Enterprise and they take it with them to their next contract.

The Portfolio of Evidence should include the following documentation:

- The development path designed for each Targeted Enterprise;
- The training courses completed by the Targeted Enterprise;
- The hours of guiding, coaching and mentoring received for each activity listed in the development plan;
- A list of outcomes achieved at each level for each activity;
- Six-monthly progress reports on the development provided (inputs) versus the actual progress made (output) by the Targeted Enterprise;
- A list of competencies.

#### **G1009.9 Training Requirements**

Only qualified trainers employed by training agencies that are accredited by the relevant Sector Education and Training Authorities (SETA), or other institutions recognised by the Department of Labour shall deliver any training. "Accredited training" refers to both the trainers as well as to the training material. Certificates affirming the successful participation in the various courses shall be presented to each attendant.

The Contractor shall facilitate in the delivery of training by instructing and motivating the hired labour and relevant Targeted Enterprises regarding attendance and participation. All training shall take place within normal working hours, or as agreed with the trainees.

#### **G1009.10 Development training**

The Contractor will arrange training to support the development of the Targeted Enterprise. This training must be provided by training providers accredited with the relevant SETA pertaining to the course material being presented. The training will take place at hours agreed with the trainees, possibly on a part time basis after hours.

The following training courses are recommended to support the development programme detailed in the contract document:

- NQF Level 2: Construction Contractor - Business owner and administration officer;
- Tender training NQF Level 3 – Business owner / Technical expert;
- Computer literacy training - Business owner and admin officer – Microsoft Windows, email, Microsoft Word and Microsoft Excel;
- General bookkeeping relevant to construction - Business owner and admin officer;
- Tendering NQF Level 4 and 5 – Business owner / Technical expert;
- Construction supervision (Roadworks) NQF Level 4 – Business owner / Technical expert.

#### **G1009.11 Safety Training**

The Targeted Enterprise safety representative is to be fully trained in all aspects of safety and his duties in this regard. The owner of the Targeted Enterprise is to be trained on their responsibilities regarding safety regulations.

#### **G1009.12 Engineering skills training**

The focus of training provided on the contract should be to support the development of the Targeted Enterprise. Engineering skills training will only be approved by the PMT when appropriate.

The Targeted Enterprise, their workforce and hired labour that show initiative will be entitled to receive structured training that will improve on-task skills necessary for the execution and successful completion of the works. The Contractor, in conjunction with the Employer's Agent, shall monitor the progress of the hired labour and each Targeted Enterprise closely and shall identify those who, in their collective opinion, will benefit from structured engineering skills training as may be provided for in the contract, and where required by the Employer's Agent shall make recommendations in this regard. The final list of candidates shall be decided between the Contractor and the Employer's Agent, and those selected shall receive formal engineering skills training in a programmed and progressive manner throughout the duration of the contract.

The training programme shall offer complete courses that could comprise some or all of the following modules:

- (i) Use and maintenance of hand tools;
- (ii) Operation of equipment;
- (iii) Manufacture and installation of minor precast concrete units;
- (iv) Erect, dismantle and maintain formwork;
- (v) Basic concrete skills;
- (vi) Excavation, backfill and compaction;
- (vii) Bricklaying;
- (viii) Erosion protection using stone pitching, gabions or reos.

**G1009.13 Training venue facility**

The training venue facility to be provided by the Contractor shall be constructed, furnished and fully serviced for the duration of the contract in accordance with section 1400 of the COLTO standard specifications. The facility shall accommodate a class of up to 25 learners and shall comprise the following:

- (a) Lecture room (interior area) = 48 m<sup>2</sup>
- (b) Ablutions (male) = 6 m<sup>2</sup>
- (c) Ablutions (female) = 6 m<sup>2</sup>
- (d) Chairs for learners (individual chairs, with backs) = 25 off
- (e) Desk area for 25 learners (500 mm width) = 12,5 m<sup>2</sup>
- (f) Chairs for trainers and management (individual chairs, with backs) = 5 off
- (g) Table area for trainers and management = 3 m<sup>2</sup>
- (h) 220/250 volt power points = 6 off
- (i) Double 80 watt fluorescent light fittings complete with ballast and tubes = 6 off
- (j) Single incandescent light fittings complete with 100 watt globes = 4 off
- (k) Wash hand basins complete with taps and drains = 4 off
- (l) Fire extinguishers, 9,0 kg, all purpose dry powder type, complete, mounted on wall with brackets = 2 off
- (m) Air conditioning units with 2,2 kW minimum capacity, mounted and with own power connection = 4 off
- (n) Voltage stabilizers = 2 off
- (o) Floodlights complete with poles and 500 Watt minimum globes and controlled by photocells = 2 off
- (p) White boards (3 m x 1,5 m) = 1 off
- (q) Venetian blinds = 12 m<sup>2</sup>

**G1010 measurement and payment**

**Item Unit**

**G10.01 Procurement of Targeted Enterprise subcontractors as described in Part G:**

(a) Contractor's charge for the management and execution of the Targeted Enterprise procurement process:

- (i) Procurement process for the totality of all tenders concluded for the appointment of CIDB contractor grading designation 1CE PE Targeted Enterprise subcontractors (4 x individual tenders prescribed, 40 copies of the tender document required for each individual tender) Prov. Sum
- (ii) Procurement process for the totality of all tenders concluded for the appointment of CIDB contractor grading designation 2CE PE Targeted Enterprise subcontractors (3 x individual tenders prescribed, 40 copies of the tender document required for each individual tender) Prov. Sum
- (iii) Procurement process for the totality of all tenders concluded for the appointment of CIDB contractor grading designation 3CE PE Targeted Enterprise subcontractors (2 x individual tenders prescribed, 40 copies of the tender document required for each individual tender) Prov. Sum

- (iv) Procurement process for the totality of all tenders concluded for the appointment of CIDB contractor grading designation 4CE PE Targeted Enterprise subcontractors (1 x individual tenders prescribed, 40 copies of the tender document required for each individual tender) Prov. Sum
- (v) Procurement process for the totality of all tenders concluded for the appointment of CIDB contractor grading designation 5CE PE Targeted Enterprise subcontractors (1 x individual tenders prescribed, 40 copies of the tender document required for each individual tender) Prov. Sum

The unit of measurement shall be the number of individual subcontract agreements concluded with Targeted Enterprise subcontractors in accordance with the procurement process described in this Part G.

Each tendered rate shall be in full compensation for the management and execution of the Targeted Enterprise procurement process in the relevant CIDB contractor grading designation scheduled, including for the compilation, printing, binding and issue of the tender documents for each tender, for the advertising of each tender, for the provision of the venue and the conducting of each compulsory briefing session for tenderers, for the conducting of each tender opening process, for the adjudication of the tenders received for each tender, for the preparation of each tender adjudication report and the review thereof in conjunction with the PMT, for the award of each tender and for the conclusion of the subcontract agreement with each successful Targeted Enterprise tenderer.

**Item Unit**

**G10.02 Construction Works for Targeted Enterprises:**

- (a) Payments associated with the construction Works carried out by Targeted Enterprise subcontractors appointed in terms of Part G PC sum (PC Sum)
- (b) Handling costs and profit in respect of subitem G10.02(a) above percentage (%)
- (c) Supply of materials and small plant to assist Targeted Enterprise subcontractors appointed in terms of Part G provisional sum (Prov. Sum)
- (d) Handling costs and profit in respect of subitem G10.02(c) above percentage (%)
- (e) Contractor's charge for the management of the Targeted Enterprise subcontractors appointed in terms of Part G lump sum (Sum)

Expenditure under subitems G10.02(a) and (c) shall be in accordance with clause 6.6 of the General Conditions of Contract, 3rd Edition 2015.

The provisional sum for subitem G10.02(a) is provided to cover the total cost of the construction Works carried out by the Targeted Enterprises as certified by the Employer's Agent, in separate payments for each Targeted Enterprise in accordance with Part G of the Particular Specifications.

The tendered percentage for subitem G10.02(b) is the percentage of the amount actually spent under subitem G10.02(a), and shall include full compensation for the handling costs of the Contractor and the profit in connection with the construction Works carried out by the Targeted Enterprise subcontractors.

The provisional sum for subitem G10.02(c) is provided to cover the total cost of the materials and small plant supplied by the Contractor to assist the Targeted Enterprises as certified by the Employer's Agent, in separate payments for each Targeted Enterprise in accordance with Part G of the Particular Specifications.

The tendered percentage for subitem G10.02(d) is the percentage of the amount actually spent under subitem G10.02(c), and shall include full compensation for the handling costs of the Contractor and the profit in connection with the supply of materials and small plant by the Contractor to assist the Targeted Enterprise subcontractors.

The tendered lump sum for subitem G10.02(e) shall include full compensation for the registration of all the subcontract agreements and the management of all the Targeted Enterprise subcontracts, including for the provision of the necessary management support, coaching, guidance and mentoring to the Targeted Enterprise subcontractors.

**Item Unit**

**G10.03 Training of learners employed by Targeted Enterprise subcontractors:**

- (a) Generic skills:
  - (i) Training costs prime cost (PC) sum
  - (ii) Handling costs and profit in respect of subsubitem G10.03(a)(i) above percentage (%)
- (b) Entrepreneurial skills:
  - (i) Training costs prime cost (PC) sum
  - (ii) Handling costs and profit in respect of subsubitem G10.03(b)(i) above percentage (%)
- (c) Engineering skills:
  - (i) Training costs prime cost (PC) sum
  - (ii) Handling costs and profit in respect of subsubitem G10.03(c)(i) above percentage (%)
- (d) Training venue facility, including the cost of transporting the learners to and from this facility lump sum (Sum)
- (e) Transportation and accommodation costs of selected learners only, while receiving off-site training:
  - (i) Transportation and accommodation costs provisional sum (Prov. Sum)
  - (ii) Handling costs and profit in respect of subsubitem G10.03(e)(i) above percentage (%)

Expenditure under subsubitems G10.03(a)(i), (b)(i), (c)(i) and (e)(i) shall be in accordance with clause 6.6 of the General Conditions of Contract, 3<sup>rd</sup> Edition 2015.

The prime cost sum for each of subsubitems G10.03(a)(i), (b)(i) and (c)(i) is provided to cover the total costs of the required training in generic skills, entrepreneurial skills and engineering skills respectively, including for the procurement of the services of the accredited trainers and their delivery of the training courses to the learners employed by Targeted Enterprise subcontractors, the provision of all training materials including all stationery and study materials, and the wages of the learners for the duration of the courses. The payment of wages to learners in terms of subsubitems G10.03(a)(i), (b)(i) and (c)(i) will only be made to those learners who attend and successfully complete each course of the approved training programme. Payment shall not be made to learners who, once selected, do not attend or only partially complete structured training courses.

The Contractor's own personnel shall be permitted to attend the training courses provided for the learners employed by the Targeted Enterprise subcontractors only to the extent that the venue and its facilities can efficiently and comfortably accommodate the additional number of learners. All additional costs relating to such attendance by the Contractor's own personnel shall be carried by the Contractor and shall not be considered for payment in terms of item G10.03, including for any additional costs related to the accredited trainers and their delivery of the training courses, the provision of additional training materials, and the wages of the learners from the Contractor's own personnel for the duration of the courses.

The tendered percentage for each of subsubitems G10.03(a)(ii), (b)(ii) and (c)(ii) is the percentage of the amount actually spent under each of subsubitems G10.03(a)(i), (b)(i) and (c)(i) respectively, and shall include full compensation for the handling costs of the Contractor and the profit in connection with the provision of the training in generic skills, entrepreneurial skills and engineering skills respectively, including for the costs of record keeping and reporting with respect to the training received by each learner, and the costs of the compilation of the portfolio of evidence with respect to each Targeted Enterprise.

The tendered lump sum for subitem G10.03(d) shall include full compensation for the provision of the training venue facility complete and serviced as specified, including for the provision of power, water, sewerage and cleaning services for the duration of the contract, for lighting, power points and voltage stabilizers, for air



conditioning, blinds, fire extinguishers, floodlights, furniture and whiteboards, for the provision of security at the facility, for all other costs necessary to maintain the facility for the duration of the contract, and for the removal of the facility on completion of the contract. The tendered lump sum shall also include full compensation for transporting the learners on each day of training from their place of work to this training venue facility, and back again after the training for the day has been delivered by the accredited trainers. Payment of the lump sum shall be made in three instalments as follows:

The first instalment, 50% of the lump sum, shall be paid after the contractor has met all his obligations regarding the provision of the training venue facility, complete and serviced as specified, and the facility has been successfully commissioned for use.

The second instalment, 35% of the lump sum, shall be paid when 75% of the training courses proposed in accordance with the Contractor's structured training programme, as approved by the PMT, have been delivered to the learners by the accredited trainers.

The third and final instalment, 15% of the lump sum, shall be paid when training for all the Targeted Enterprise subcontracts has been concluded and the facility has been dismantled and removed from the site.

The provisional sum for subsubitem G10.03(e)(i) is provided to cover all costs related to the transportation and accommodation costs of selected learners only, while receiving off-site training, where such learners have been specifically selected in conjunction with the PMT to receive such off-site training and where such training cannot be delivered using the training venue facility provided by the Contractor in terms of subitem G10.03(d).

The tendered percentage for subsubitem G10.03(e)(ii) is the percentage of the amount actually spent under subsubitem G10.03(e)(i), and shall include full compensation for the handling costs of the Contractor and the profit in connection with the transportation and accommodation costs of selected learners only, while receiving off-site training.

Add the following new payment item:

<u>ITEM</u>	<u>UNIT</u>
G10.04 Penalties:	
(a) Fixed penalty for non-compliance for Contract Participation Goals requirements per occurrence requirements per occurrence	No

A fixed penalty deduction will be calculated in accordance with item G1003(d)

Add the following new payment item:

<u>ITEM</u>	<u>UNIT</u>
G10.05 Part G:	
(a) The Contract Participation Target for Targeted Enterprise	Prov. Sum

Expenditure under these items will be made in accordance with the Part G

**PRESCRIBED CIDB CONTRACTOR GRADING DESIGNATION ALLOCATION DIAGRAM FOR WORKS TO BE CONSTRUCTED BY TARGETED ENTERPRISE SUBCONTRACTORS IN TERMS OF PART G**

The prescribed CIDB contractor grading designation allocation diagram for the Works to be constructed by Targeted Enterprise subcontractors in terms of this contract is given below

SECTION	DESCRIPTION	TARGETED ENTERPRISE CIDB CONTRACTOR GRADING DESIGNATION		
		1CE PE Max: R0,20 m	2CE PE Max: a) R0,65 m	3CE PE Max: R2,00 m
1500	ACCOMMODATION OF TRAFFIC	X <sub>(1)</sub>		

1600	OVERHAUL		X <sub>(1)</sub>	
1700	CLEARING AND GRUBBING		X <sub>(1)</sub>	
2100	DRAINS	X <sub>(1)</sub>		
2200	PREFABRICATED CULVERTS		X <sub>(1)</sub>	
2300	CONCRETE KERBING, CONCRETE CHANNELLING, CHUTES AND DOWNPIPES, AND CONCRETE LININGS FOR OPEN DRAINS			X <sub>(1)</sub>
3100	BORROW MATERIALS		X <sub>(1)</sub>	
3200	SELECTION, STOCKPILING AND BREAKING DOWN THE MATERIAL FROM BORROW PITS, CUTTINGS AND EXISTING PAVEMENT LAYERS, AND PLACING AND COMPACTING OF THE GRAVEL LAYERS			X <sub>(1)</sub>
3300	MASS EARTHWORKS			X <sub>(1)</sub>
3400	PAVEMENT LAYERS OF GRAVEL MATERIAL			
3500	STABILIZATION			
3600	CRUSHED STONE BASE			
3800	BREAKING UP OF EXISTING PAVEMENT LAYERS			
4100	PRIME COAT			
4200	ASPHALT BASE AND SURFACING			
5100	PITCHING, STONEMWORK AND PROTECTION AGAINST EROSION			
5100	PITCHING, STONEMWORK AND PROTECTION AGAINST EROSION			
5200	GABIONS	X <sub>(1)</sub>		
5400	GUARDRAILS	X <sub>(1)</sub>		
5600	ROAD SIGNS			
5700	ROAD MARKINGS	X <sub>(1)</sub>		
5800	LANDSCAPING AND PLANTING PLANTS			
5900	FINISHING THE ROAD AND ROAD RESERVE AND TREATING OLD ROADS			
6100	FOUNDATIONS FOR STRUCTURE			
6200	FALSEWORK, FORMWORK AND CONCRETE FINISH			
6300	STEEL REINFORCEMENT FOR STRUCTURES			
6400	CONCRETE FOR STRUCTURES			
6600	NO-FINES CONCRETE, JOINTS, BEARINGS, PARAPETS AND DRAINAGE FOR STRUCTURES			
6700	STRUCTURAL STEELWORK			
7400	PATENTED EARTH RETAINING SYSTEMS			

---

	TOTAL NUMBER OF TARGETED ENTERPRISE SUBCONTRACTORS PRESCRIBED FOR EACH CIDB CONTRACTOR GRADING DESIGNATION			
--	--	--	--	--

**ANNEXURE A**

**SCHEDULE OF QUANTITIES  
PART G: SMALL CONTRACTOR DEVELOPMENT**

## TABLE OF CONTENTS

	<b>PAGE NO.</b>
C4: SITE INFORMATION .....	SI. 2
C4.1: LOCALITY PLAN .....	SI. 2
C4.2: DRAWINGS .....	SI. 3

## C4: SITE INFORMATION

### C4.1: LOCALITY PLAN

The location of the site is as per the attached Locality Plan.



#### C4.1.1: Access

The site shall not only include the proclaimed road reserve but shall be extended in the broader sense to take account of all areas occupied by the Contractor, be it deliberate or unintentional, in the execution of the contract. Incidental intrusion into private or tribal property outside the road reserve shall not be permitted without the owner's written authority. Any such agreement reached with a private or tribal landowner (occupier) shall include the proviso that any material or equipment on that site shall remain the exclusive property of the Employer in terms of the contract

#### C4.2.1: Geotechnical Report

The detailed Geotechnical investigation was undertaken, and a Geotechnical Report prepared. The report will be emailed to tenderers upon request.

## C4.2: DRAWINGS

The drawings issued to tenders as part of the tender documents must be regarded as provisional and preliminary for the tenderer's benefit to generally assess the scope of work. The drawings are issued as a separate book of drawings. The work shall be carried out in accordance with the latest available revision of the drawings approved for construction (AFC)

At commencement of the contract, the Engineer shall deliver to the Contractor copies of the AFC drawings and any instructions required for the commencement of the works. From time to time thereafter during the progress of the works, the Engineer may issue further drawings for construction purposes as may be necessary for adequate construction, completion and defects correction of the works.

All drawings and specifications and copies thereof remain the property of the Employer, and the Contractor shall return all drawings and copies thereof to the Employer at the completion of the contract.

### C4.2.1 List of drawings attached

Tender drawings are issued separately and are listed hereunder:

Layout Plan and Cross Sections	K054.4 – ROT -100
Layout Plan and Cross Sections: D207	K054.4 – ROT - 101
Bus Shelter	



MUNICIPAL OFFICES BUS SHELTER  
SCALE 1:500

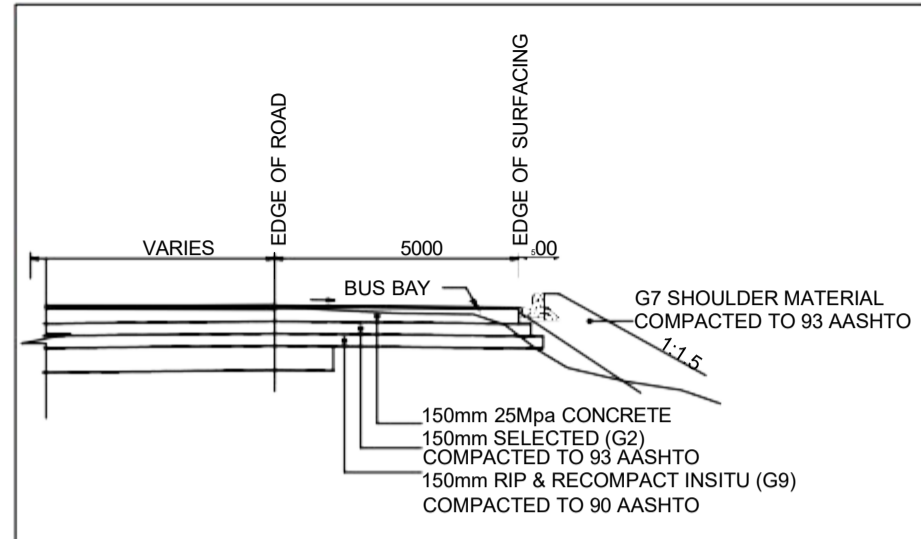

BUS BAY CROSS SECTION  
N.T.S

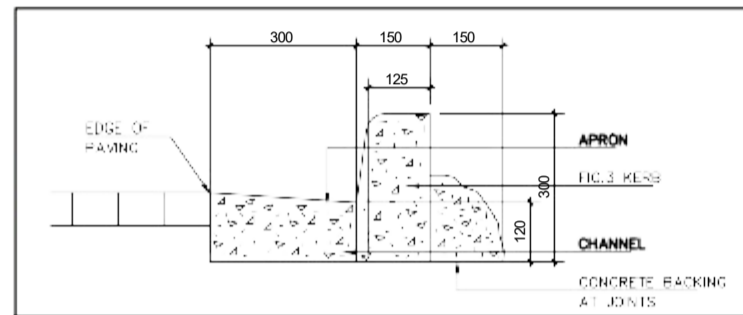

UNMOUNTABLE KERB  
N.T.S



CREIGHTON VALLEY CHEESE CO TRUCK STOP  
SCALE 1:300

- GENERAL NOTES :-**
- 1) ALL LEVELS, DIMENSIONS AND SETTING OUT DETAILS TO BE VERIFIED BY CONSULTANT AND CONTRACTORS ON SITE PRIOR TO CONSTRUCTION.
  - 2) UNDERGROUND SERVICE CROSSINGS AND MARKERS REQUIRED.
  - 3) ALL SURVEY AND SETTING OUT DATA PROVIDED IS BASED ON WGS84.
  - 4) REFERENCE DRAWINGS:  
K054.3-ROA-200 (SD0302E)  
K054.3-ROA-201 (SD0304E)  
K054.3-ROA-202 (SD0305C)

**KEY:**

	ROAD EDGE
	CADASTRAL

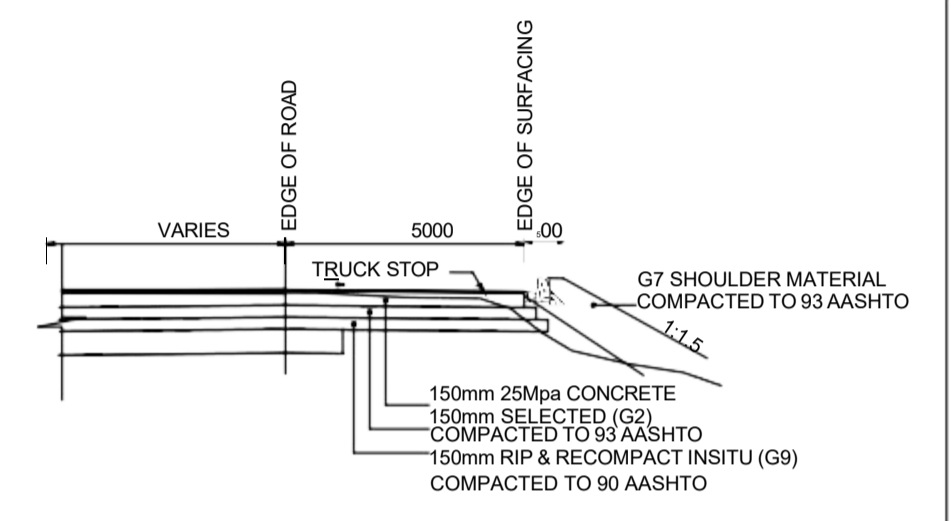

TRUCK STOP CROSS SECTION  
SCALE 1:300



CONCRETE PAVED WALKWAY  
SCALE 1:500

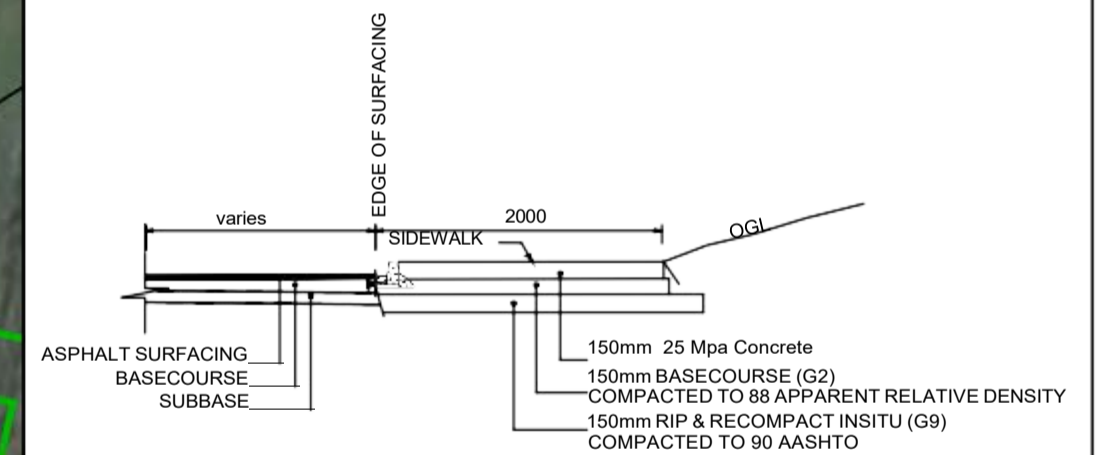

TRUCK STOP CROSS SECTION  
SCALE 1:300

FOR TENDER

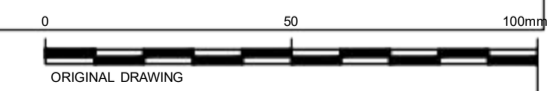

T	ISSUED FOR TENDER	18/10/2022	V. MBOLA	H. FUYANA
Δ	DESCRIPTION OF REVISION(S)	DATE	CHECKED	APPROVED

DESIGNED	V. MBOLA
CHECKED	H. FUYANA
DRAWN	V. MBOLA
CHECKED	H. FUYANA
PROJECT ENGINEER	HLOSOKUJHLE FUYANA
REGISTRATION NO.	201330304

PHYSICAL ADDRESS:  
18 York Road  
CREIGHTON  
3610  
TEL: (031) 764 2763  
FAX: (086) 542 4984  
e-mail: admin@fmaengineers.co.za



H. FUYANA  
(REGISTRATION NO.: 201330304) SIGNATURE: \_\_\_\_\_

PHYSICAL ADDRESS:  
MAIN STREET  
CREIGHTON  
3263  
ON BEHALF OF CLIENT: SIGNATURE: \_\_\_\_\_



PROJECT/DRAWING TITLE  
**DR NKOSAZANA DLAMINI ZUMA LOCAL MUNICIPALITY  
CREIGHTON TOWN UPGRADE PHASE 2**  
**LAYOUT PLAN AND CROSS SECTIONS: WALKWAY, BUS SHELTERS AND  
TRUCK STOPS**

SCALE:	1:1000	CONTRACT No.	B035/22/23
SHEET	1 OF 1	PROJECT No.	K054.4
DRAWING No.			K054.4 - R0T-100
REVISION			T





PAVED WALKWAY  
SCALE 1:500



D207 P8-3 INTERSECTION  
SCALE 1:500

GENERAL NOTES :-

- 1) ALL LEVELS, DIMENSIONS AND SETTING OUT DETAILS TO BE VERIFIED BY CONSULTANT AND CONTRACTORS ON SITE PRIOR TO CONSTRUCTION.
- 2) UNDERGROUND SERVICE CROSSINGS AND MARKERS REQUIRED.
- 3) ALL SURVEY AND SETTING OUT DATA PROVIDED IS BASED ON WGS84.
- 4) REFERENCE DRAWINGS:  
K054.3-ROA-200 (SD0302E)  
K054.3-ROA-201 (SD0304E)  
K054.3-ROA-202 (SD0305C)

KEY:

	ROAD EDGE
	CADASTRAL
	STORM WATER PIPE
	STREET LIGHT

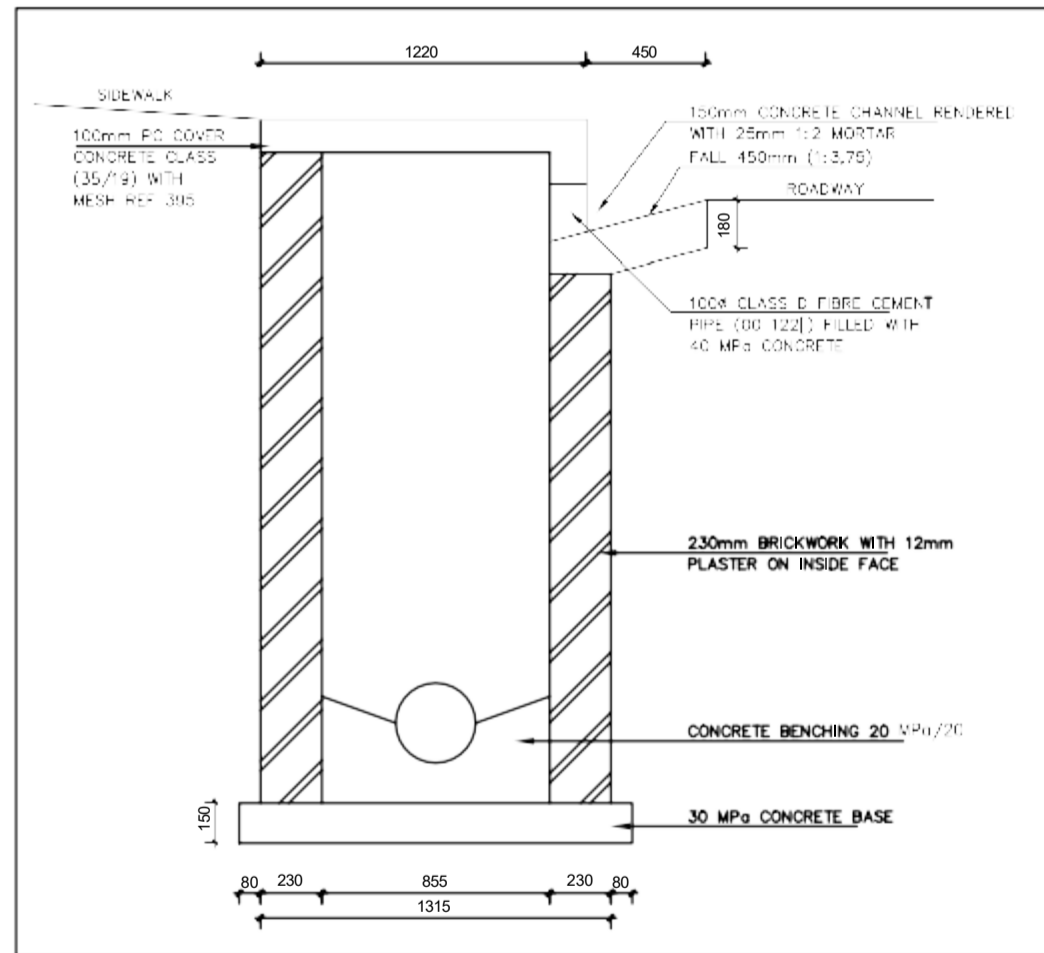

SECTION THROUGH KERB INLET SHAFT TO PIPE  
N.T.S

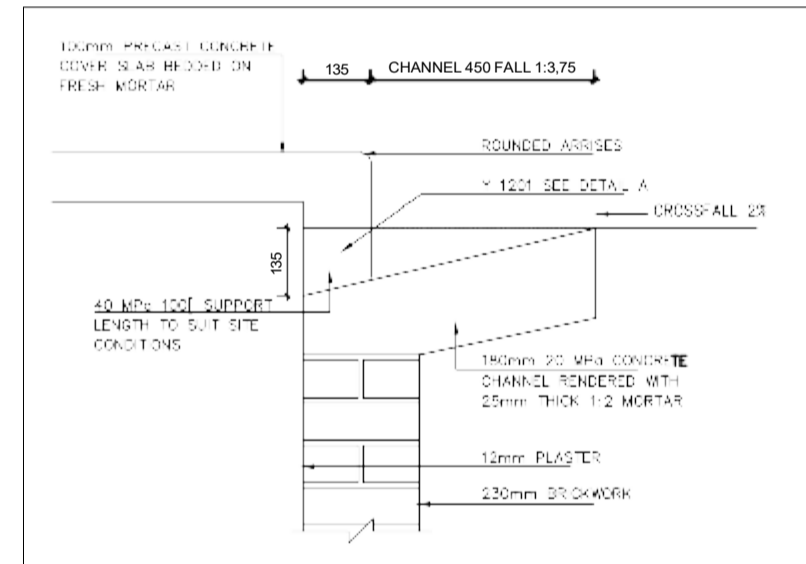

DETAIL OF CHANNEL & KERB INLET OPENING  
N.T.S

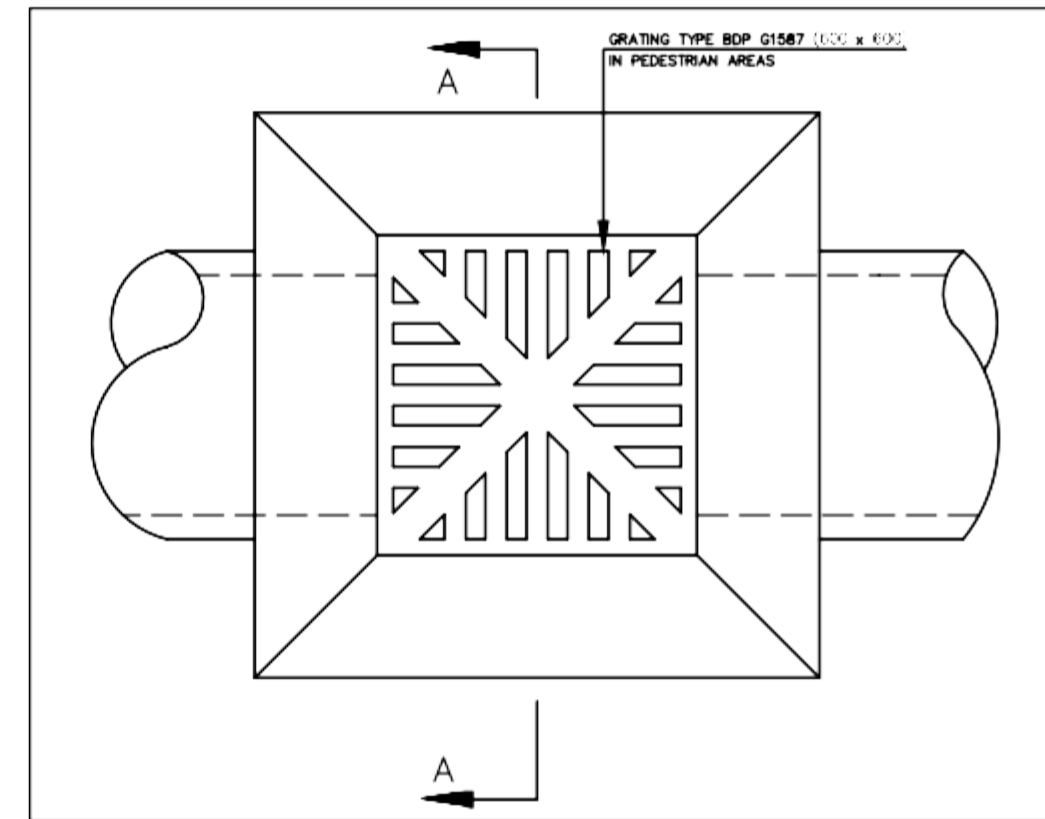

GRID INLET  
N.T.S

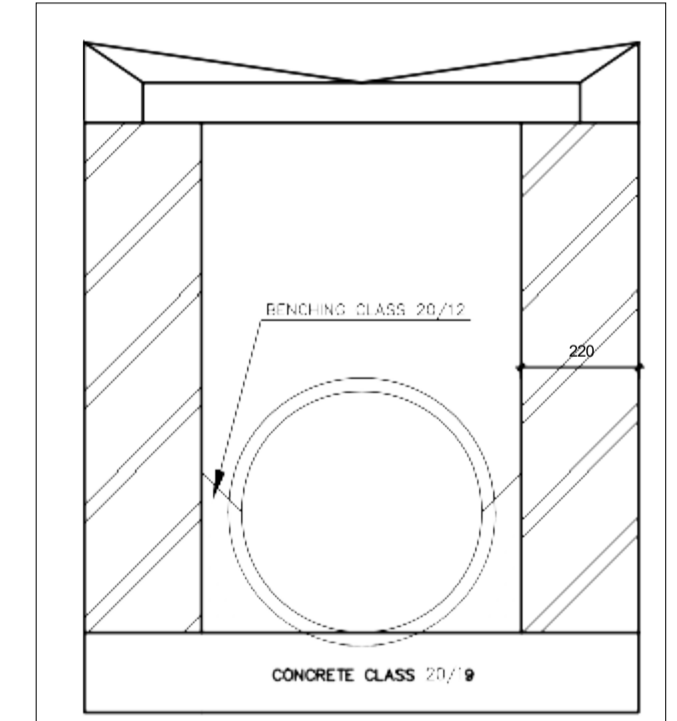

SECTION THROUGH KERB INLET SHAFT TO PIPE  
N.T.S

FOR TENDER

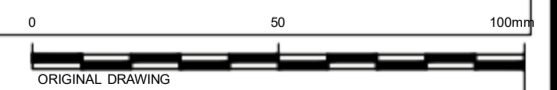

T	ISSUED FOR TENDER	18/10/2022	V. MBOLA	H. FUYANA
Δ	DESCRIPTION OF REVISION(S)	DATE	CHECKED	APPROVED

DESIGNED	V. MBOLA
CHECKED	H. FUYANA
DRAWN	V. MBOLA
CHECKED	H. FUYANA
PROJECT ENGINEER	HLOSOKUHE FUYANA
REGISTRATION NO.:	201330304

PHYSICAL ADDRESS:  
18 York Road  
GILLITTS  
3610  
TEL: (031) 764 2763  
FAX: (086) 542 4094  
e-mail: admin@fmaengineers.co.za



H. FUYANA  
(REGISTRATION NO.: 201330304) SIGNATURE: \_\_\_\_\_

PHYSICAL ADDRESS:  
MAIN STREET  
CREIGHTON  
3263  
ON BEHALF OF CLIENT: SIGNATURE: \_\_\_\_\_

PROJECT/DRAWING TITLE  
DR NKOSAZANA DLAMINI ZUMA LOCAL MUNICIPALITY  
CREIGHTON TOWN UPGRADE PHASE 2  
LAYOUT PLAN AND CROSS SECTIONS: D207 P8-3 INTERSECTION

SCALE:	1:1000	CONTRACT No.:	B035/22/23
SHEET	OF 1	PROJECT No.:	K054.4
DRAWING No.:	K054.4 - R0T-101	REVISION	T

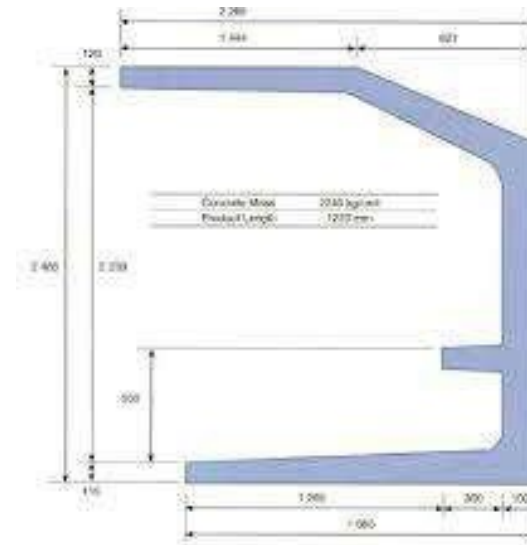

Rocla Bus Shelter